



# İçindekiler

## Index

### Inhaltsverzeichnis



<b>Genel Bilgiler</b> <i>General Info.</i> Einführung	<b>Sembollerin Açıklaması</b>	<i>Key of Symbols</i>	Erklärung der Bezeichnungen	03
	<b>Ürün Yelpazesi</b>	<i>Production Range</i>	Produktpalette	04
	<b>Y Serisi Redüktörlerin Genel Özellikleri</b>	<i>General Specifications of Y Series Gearboxes</i>	Allgemeine Eigenschaften von Y Serie Getrieben	06
	<b>Teknik Tanımlamalar</b>	<i>Technical Explanations</i>	Technische Erläuterungen	07
	<b>Teknik Özellikler</b>	<i>Technical Specifications</i>	Technische Informationen	07
	<b>Aksesuarlar</b>	<i>Accessories</i>	Zubehör	08
	<b>Yüzey Koruması</b>	<i>Surface Protection</i>	Oberflächenschutz	08
	<b>Tip Tanımlaması</b>	<i>Unit Designation</i>	Typenbezeichnungen	10
	<b>Mil Pozisyonları</b>	<i>Shaft Arrangements</i>	Typenbezeichnungsbeispiele	11
	<b>Redüktör Dönüş Yönleri</b>	<i>Direction of Rotation</i>	Getriebedrehrichtungen	12
	<b>Servis Faktörü</b>	<i>Service Factor</i>	Betriebsfaktor	13
	<b>Yük Sınıflandırması</b>	<i>Load Classification</i>	Belastungsart	17
	<b>Radyal Yükler</b>	<i>Overhung Loads</i>	Querkräfte	18
	<b>Radyal Yüklerin Hesabı</b>	<i>Calculation Of Overhung Loads</i>	Berechnung der Querkräfte	19
	<b>Ekstruder Tiplerde Müsade Edilebilir Eksenel Yükler</b>	<i>Permissible Axial Loads for Extruder Types</i>	Zulässige Axialkräfte für Extruder Typ Getrieben	20
	<b>Eşdeğer Güç Hesabı</b>	<i>Equivalent Power Calculation</i>	Äquivalente Leistung	22
	<b>Eşdeğer Güç Hesabı Örneği</b>	<i>Equivalent Power Cal. Example</i>	Beispiel für äquivalente Leistung	23
	<b>Redüktör Seçimi</b>	<i>Gearbox Selection</i>	Getriebeauswahl	24
	<b>Redüktör Seçim Formu</b>	<i>Gearbox Selection Form</i>	Formular für Getriebeauswahl	26
	<b>Sembollerin Açıklaması</b>	<i>Key of Symbols</i>	Erklärung der Bezeichnungen	27
	<b>Yağlama</b>	<i>Lubrication</i>	Schmierung	30
	<b>Yağ Tipleri</b>	<i>Oil Types</i>	Schmierstoffe	31
	<b>Montaj Pozisyonları</b>	<i>Mounting Positions</i>	Bauformen	32
	<b>Yağ Miktarları</b>	<i>Oil Quantities</i>	Ölmengen Tabellen	33
<b>Motorlar</b> <i>Motors</i> Motoren	<b>AC Motorlar</b>	<i>AC Motors</i>	Drehstrommotoren:	34
	<b>a- Genel Özellikler</b>	<i>a- General Spec. of AC Motors</i>	a-Eigensch. des Drehstrommotors	34
	<b>b- Çalışma Türleri</b>	<i>b-Modes of Operation</i>	b-Betriebsarten	35
	<b>c- Koruma Sınıfı</b>	<i>c- Protection Class</i>	c- Schutzarten	36
	<b>d- İzolasyon Sınıfı</b>	<i>d- Insulation Class</i>	d- Isolationsklasse	36

Y0204-0520



# İçindekiler

## Index

### Inhaltsverzeichnis



<b>Motorlar</b> <i>Motors</i> Motoren	<b>e- Verim Sınıfları</b>	<i>e- Efficiency Classes</i>	e- Energieeffizienzklassen	36
	<b>f- AC Frekans İnvörtörler</b>	<i>f- AC Frequency Inverters</i>	f- AC Frequenz Umrichter	37
	<b>DC Motorlar</b>	<i>DC Motors</i>	DC Motoren	
	<b>a- Genel Özellikler</b>	<i>a- General Specif. of DC Motors</i>	a- Eigenschaften von DC Motoren	38
	<b>b- DC Motorların Çalışma İlkeleri</b>	<i>b- Operating principals of DC Motors</i>	b- Funktionsprinzip der DC Motoren	38
	<b>c- DC Motor Çeşitleri</b>	<i>c- Types of DC Motors</i>	c- Arten von DC Motoren	38
	<b>d- DC Motorlarda Hız Kontr.</b>	<i>d- Speed Control of DC motors</i>	d- Drehzahlkontrolle DC Motoren	38
<b>Frenler</b> <i>Brakes</i> Bremsen	<b>Elektromanyetik Frenler</b>	<i>Electromagnetic Brakes</i>	Elektromagnetische Bremsen	39
	<b>Fren Çeşitleri</b>	<i>Brake Types</i>	Bremsenarten	40
	<b>Fren Bağlantı Şekli</b>	<i>Connection Types</i>	Schaltungsarten	41
	<b>Fren Seçimi</b>	<i>Brake Selection</i>	Bremswahl	41
	<b>Frenin Termik Kapasitesi</b>	<i>The Thermal Capacity of Brake</i>	Therm. Kapazität der Bremsen	42
<b>Güç Devir Tabl.</b> <i>Perform. Tables</i> Leistungs- und Drehzahl- tabellen	<b>Motorsuz Güç Devir Tabloları</b>	<i>Gear Units Performance Tables</i>	Getriebe Leistung- und Drehzahl- übersicht	43
<b>Ölçü Sayfaları</b> <i>Dimension Pages</i> Abmessungs- tabellen	<b>YRM,YRC,YRD serileri</b>	<i>YRM,YRC,YRD series</i>	<b>YRM,YRC,YRD</b> Serie	59
	<b>YRE serileri</b>	<i>YRE series</i>	YRE Serie	85



# Genel Bilgiler

## General Information

### Einführung



#### Se mbollerin Açıklaması

$c_t$  : Anahtarın devreye girme zamanı katsayısı

$f_s$  : Servis faktörü

$F_{ama}$  : Çıkış milinde müsaade edilen eksenel yükler [kN]

$F_{ame}$  : Giriş milinde müsaade edilen eksenel yükler [kN]

$F_{qam}$  : Çıkış milinde izin verilen radyal yükler [N]

$F_{qem}$  : Giriş milinde izin verilen radyal yükler [N]

$F_{qa}$  : Çıkış miline gelen radyal yükler [N]

$F_{qe}$  : Giriş miline gelen radyal yükler [N]

$F_q$  : Radyal yönde çıkış miline gelen yükler [N]

$F_a$  : Eksenel yönde çıkış miline gelen yükler [N]

$i$  : Tahvil oranı

$J_{ext}$  : Motor miline indirgenmiş toplam dış atalet momenti [kgm<sup>2</sup>]

$M_2$  : Çıkış momenti [Nm]

$M_a$  : Anma momenti [Nm]

$n_1$  : Redüktör giriş mili devri [d/dak]

$n_2$  : Redüktör çıkış mili devri [d/dak]

$P_{eq}$  : Eşdeğer güç [W]

$P_e$  : Nominal güç (Bak. Güç-Devir Tabloları) [W]

$P_M$  : Tahrik edilecek makina için gerekli güç (Değişken yükler için eşdeğer güç alınır) [kW]

$t$  : Zaman [s]

$T_e$  : Eşdeğer moment [Nm]

$P_t$  : Termik Güç

#### Key of Symbols

$c_t$  : Coefficient of switch on time.

$f_s$  : Service factor

$F_{ama}$  : Permissible axial load on output shaft [kN]

$F_{ame}$  : Permissible axial loads on input shaft [kN]

$F_{qam}$  : Permissible overhung loads on output shaft [N]

$F_{qem}$  : Permissible overhung loads on input shaft [N]

$F_{qa}$  : Overhung loads applied to the output shaft [N]

$F_{qe}$  : Overhung loads on input shafts [N]

$F_q$  : Overhung loads on output shaft [N]

$F_a$  : Axial loads on output shaft [N]

$i$  : Transmission ratio

$J_{ext}$  : The total inertia of rotating parts at outside reduced at the motor shaft [kgm<sup>2</sup>]

$M_2$  : Output torque [N]

$M_a$  : Nominal torque [Nm]

$n_1$  : Input speed of gearbox [rpm]

$n_2$  : Output speed of gearbox [rpm]

$P_{eq}$  : Equivalent power [W]

$P_e$  : Nominal power (given on performance tables) [W]

$P_M$  : Power consumption of the driven machine (for alternating power, refer to equivalent power) [kW]

$t$  : Time [s]

$T_e$  : Equivalent torque [Nm]

$P_t$  : Thermal Power

#### Erklärung der Bezeichnungen

$c_t$  : Koeffizient der Tätigkeitszeit von Schalter

$f_s$  : Betriebsfaktor

$F_{ama}$  : Zulässige Axialkräfte auf Abtriebswelle [kN]

$F_{ame}$  : Zulässige Axialkräfte auf Antriebswelle [kN]

$F_{qam}$  : Zulässige Querkräfte auf Abtriebswelle [N]

$F_{qem}$  : Zulässige Querkräfte auf Antriebswelle [N]

$F_{qa}$  : Querkräfte auf Abtriebswelle [N]

$F_{qe}$  : Querkräfte auf Antriebswelle [N]

$F_q$  : Querkräfte auf Abtriebswelle [N]

$F_a$  : Axialkräfte auf Abtriebswelle [N]

$i$  : Übersetzungsverhältnis

$J_{ext}$  : Die Gesamtträgheit der rotierende Teile von der Ausgangsseite reduziert auf Motorwelle [kgm<sup>2</sup>]

$M_2$  : Ausgangsdrehmoment [N]

$M_a$  : Nennndrehmoment [Nm]

$n_1$  : Antriebsdrehzahl [U/min]

$n_2$  : Abtriebsdrehzahl [U/min]

$P_{eq}$  : Äquivalente Leistung [W]

$P_e$  : Getriebe Nennleistung (siehe Leistung-Drehzahl Tabellen) [W]

$P_M$  : Leistung benötigt an der Abtriebswelle (Zur Berechnung bei variabler Leistungen äquivalente Leistung benutzen) [kW]

$t$  : Zeit [s]

$T_e$  : Äquivalentes Drehmoment [Nm]

$P_t$  : Wärme-Grenzleistungen



# Genel Bilgiler

## General Information

### Einführung



#### Ürün Yelpazesi

Elinizdeki katalog sadece **Y serisi** ürünleri içermektedir.

##### - M ve N Serisi

Helisel alın dişliye sahip, giriş ve çıkış milleri aynı düzlem üzerinde ve birbirine paralel uzanan, üzerlerinde bulunan ayak veya flanş ile makina-ya sabitlenen redüktörlerdir. Dolu mil çıkışlıdır.

##### - D Serisi

Helisel alın dişliye sahip, giriş ve çıkış milleri aynı düzlem üzerinde, birbirine paralel ve belirli bir aralıkta yerleştirilmiş, iki yan yüzde bulunan bağlantı civataları, flanş veya tork kolu ile makina-ya sabitlenen redüktörlerdir. Delik milli veya mil çıkışlı olabilir.

##### - E Serisi

Sonsuz vida ve çark dişlili, belirli bir aralıkta ve birbirine dik konumlandırılmış giriş ve çıkış millerine sahip, çepçevre konumlandırılmış ayak bağlantıları, flanş veya tork kolu ile makina-ya sabitlenebilen redüktörlerdir. Delik milli veya mil çıkışlı olabilir.

##### - Y Serisi

Yatık tip redüktörler, ağır şartlarda çalışmak üzere dizayn edilmiş redüktör tipleridir. Bu tiplerde redüktör ile bunu tahrik eden mekanizma arasında değişik bağlantı şekilleri mevcuttur (Mekanik ve hidrolik kaplinler, çeşitli tip kayışlar ve zincirle tahrik gibi). Delik milli veya mil çıkışlı olabilir.

##### - K Serisi

Helisel alın dişli ve konik dişlilerden oluşan, birbirine dik ve belirli bir aralıkta konumlandırılmış giriş ve çıkış milline sahip, çepçevre sunulan ayaklar, flanş veya tork kolu ile makina-ya sabitlenen redüktörlerdir. E serisinden farklı olarak yüksek verime sahiptirler. Delik milli veya mil çıkışlı olabilir.

##### - H ve B Serisi

Helisel ve/veya konik dişliye sahip ağır hizmet tipi redüktörlerdir. Giriş ve çıkış milleri birbirine paralel veya dik olabilir. Her yönden bağlantı için ayak bağlantıları bulunur. Opsiyonel olarak flanş ile de bağlanabilir. Delik milli veya mil çıkışlı olabilir.

##### - T Serisi

T Serisi redüktörler helisel dişli iki kademe motorsuz delik milli redüktörlerdir. T Serisi redüktörler delik milli olması ve kompakt gövde yapısı sayesinde daha küçük hacimli alanlara montajı yapılabilmektedir.

##### - P ve R Serisi

P ve R Serisi redüktörler planet dişli redüktörlerdir. Endüstriyel ve mobil uygulamalarda kullanılırlar. Diğer redüktör tiplerine göre daha küçük hacimde daha büyük tork iletebilirler.

##### - VR Serisi

VR vinç redüktörleri M1 - M8 (1Dm - 5m) yük sınıflarına uygun olarak, çift veya sabit devirli frenli motorlarla üretilebilmektedir.

#### Production Range

*This catalogue is containing Y series of gearboxes only.*

##### - M and N Series

*M and N series of YILMAZ REDÜKTÖR are helical geared. The input and output shafts are parallel to each other and on the same plane. The gearbox can be connected to the machine by using the foot or flange on the gearbox. Has solid output shaft.*

##### - D Series

*D series are helical geared gearboxes with parallel input and output shafts. The shafts have a distance in between and located on the same plane. The gearbox can be assembled to the machine by using the foot, the connection screws on the sides, flange or torque arm on the gearbox. Can have hollow or solid output shaft.*

##### - E Series

*E series gearboxes are with worm and worm-wheel. The input and output shafts are perpendicular to each other and have a distance in between. It can be assembled to the driven machine by the use of the foot, flange or torque arm on the gearbox. Can have hollow or solid output shaft.*

##### - Y Series

*Horizontal type gearboxes are designed to operate in heavy conditions. In these types there are a lot of combination forms between gearbox and driver (for example, mechanic and hydraulic couplings, various belt and chain drives etc.). Can have hollow or solid output shaft.*

##### - K Series

*These are gearboxes with helical and bevel gears. The input and output shafts are perpendicular to each other and have a distance in between. It can be assembled to the driven machine using the foot, flange or torque arm on the gearbox. They have high efficiency compared to E series. Can have hollow or solid output shaft.*

##### - H and B Series

*These gearboxes are helical or/and bevel geared industrial gearboxes. The input and output shafts can be arranged parallel or perpendicular to each other. The gearbox can be assembled by the use of the foot connections on each side. Flange connections are optional. Can have hollow or solid output shaft.*

##### - T Series

*T Series are gear units which are helical geared, two staged, hollow shaft mounted gear units and manufactured according to monoblock principal. T Series gearboxes have hollow shaft and compact housing so that T series can be mounted on smaller places.*

##### - P and R Series

*P and R Series gearboxes are planetary gearboxes. They are mostly used by industrial and mobile applications. Planetary gearboxes can transfer high torques in small volumes compared to other gearboxes.*

##### - VR Serie

*VR hoist drives are produced according to M1 - M8 (1Dm - 5m) load classification.*

#### Produktpalette

Dieses Katalog umfasst nur die **Y Serien** Getriebe.

##### - M und N Serie

Diese Modelle sind Stirnradgetriebe mit parallelen Antriebs- und Abtriebswelle auf einer Ebene. Die Getriebe werden mit Fuß- oder Flanschverbindung an die angetriebene Maschine angekoppelt. Hat Vollwelle am Ausgang.

##### - D Serie

Diese Getriebe sind Stirnradgetriebe mit paralleler Antriebs- und Abtriebswelle, die auf einer Ebene liegen und einen Abstand zueinander haben. Diese Getriebe wird seitlich mit Gewindelöchern am Maschine oder mit einem Flansch verbindet. Kann Voll- und Hohlwelle am Ausgang haben.

##### -E Serie

Diese Getriebe bestehen aus Schnecke und Schneckenrad. Die Antriebs- und Abtriebswellen sind senkrecht zueinander und haben einen bestimmten Abstand. Das Getriebe wird mit Fußbefestigung, Flanschverbindung oder Drehmomentstütze an die angetriebene Maschine montiert. Kann Voll- und Hohlwelle am Ausgang haben.

##### - Y Serie

Diese Getriebe sind für den Einsatz unter schweren Bedingungen ausgelegt. Bei dieser Ausführung gibt es sehr viele verschiedene Verbindungsmöglichkeiten zwischen Antrieb und Getriebe (Zum Beispiel; mechanische und hydraulische Kupplungen, Riemtrieb, Kettentrieb usw.). Kann Voll- und Hohlwelle am Ausgang haben.

##### - K Serie

Diese Getriebe bestehen aus Stirnräder und Kegelräder. Die Antrieb und Abtriebswellen sind senkrecht und haben einen Abstand zueinander. Das Getriebe wird mit Fußbefestigung, Flanschverbindung oder Drehmomentstütze an die angetriebene Maschine montiert. Der Wirkungsgrad ist wesentlich höher als E Serie. Kann Voll- und Hohlwelle am Ausgang haben.

##### - H und B Serie

Diese Getriebe sind geeignet für industrielle Anwendungen und haben parallelen oder senkrechten Antrieb und Abtriebswelle auf einer Ebene. Das Getriebe kann mit Fuß, die auf jede Seite der Getriebe vorhanden sind, oder optional mit Flansch an die angetriebene Maschine montiert werden. Kann Voll- und Hohlwelle am Ausgang haben.

##### - T Serie

TSerien Getriebe sind zwei stufige, schrägverzahnte Hohlwellenflachgetriebe in Monoblockgehäuse. Die T Serie hat eine kompakte Gehäuse und ist serienmäßig mit Abgangshohlwelle hergestellt, so dass das Getriebe minimalen Platzbedarf hat.

##### - P und R Serie

P und R Serie sind Planetengetriebe, die vielseitig im Industrie und bei mobiler Anwendungen einsetzbar sind, mit Planetenzahnräder. Planetengetriebe können im Vergleich zu anderen Getrieben größere Drehmomente bei kleineren Bauvolumen übertragen.

##### - VR Serie

VR Krane und Hebezeuge werden geeignet zur Belastungsart M1 - M8 (1Dm - 5m) hergestellt.





## Genel Bilgiler General Information Einführung



M ...

13 farklı büyüklükte;  
Moment aralığı: 50 - 18.000 Nm  
Devir aralığı: 0,1 - 500 d/dak  
13 different sizes:  
Torque range: 50 - 18.000 Nm  
Speed range: 0,1 - 500 rpm  
13 verschiedene Baugrößen:  
Drehmomentbereich: 50 - 18.000 Nm  
Drehzahlbereich : 0,1 - 500 U/min



N ...

13 farklı büyüklükte;  
Moment aralığı: 50 - 18.000 Nm  
Devir aralığı: 0,1 - 500 d/dak  
13 different sizes:  
Torque range: 50 - 18.000 Nm  
Speed range: 0,1 - 500 rpm  
13 verschiedene Baugrößen:  
Drehmomentbereich: 50 - 18.000 Nm  
Drehzahlbereich : 0,1 - 500 U/min



E ...

8 farklı büyüklükte;  
Moment aralığı: 5 - 1.000 Nm  
Devir aralığı: 0,1 - 400 d/dak  
8 different sizes:  
Torque range: 5 - 1.000 Nm  
Speed range: 0,1 - 400 rpm  
8 verschiedene Baugrößen:  
Drehmomentbereich: 5-1.000 Nm  
Drehzahlbereich : 0,1-400 U/min



K ...

12 farklı büyüklükte;  
Moment aralığı: 200 - 20.000 Nm  
Devir aralığı: 0,1 - 400 d/dak  
12 different sizes:  
Torque range: 200 - 20.000 Nm  
Speed range: 0,1 - 400 rpm  
12 verschiedene Baugrößen:  
Drehmomentbereich: 200 - 20.000 Nm  
Drehzahlbereich : 0,1 - 400 U/min



D ...

10 farklı büyüklükte;  
Moment aralığı: 130 - 18.000 Nm  
Devir aralığı: 0,1 - 350 d/dak  
10 different sizes:  
Torque range: 130 - 18.000 Nm  
Speed range: 0,1 - 350 rpm  
10 verschiedene Baugrößen:  
Drehmomentbereich: 130 - 18.000 Nm  
Drehzahlbereich : 0,1 - 350 U/min



Y ...

25 farklı büyüklükte;  
Moment aralığı: 1.200 - 43.000 Nm  
Devir aralığı: 2,6 - 990 d/dak  
25 different sizes:  
Torque range: 1200 - 43000Nm  
Speed range: 2,6 - 990 rpm  
25 verschiedene Baugrößen:  
Drehmomentber. :1200-43000 Nm  
Drehzahlbereich : 2,6-990 U/min



H ...

20 farklı büyüklükte;  
Moment aralığı: 2.500 - 470.000 Nm  
Devir aralığı: 0,1 - 250 d/dak  
20 different sizes:  
Torque range: 2.500 - 470.000 Nm  
Speed range: 0,1 - 250 rpm  
20 verschiedene Baugrößen:  
Drehmomentber. :2.500 - 470.000 Nm  
Drehzahlbereich : 0,1 - 250 U/min



B ...

20 farklı büyüklükte;  
Moment aralığı: 5.000 - 470.000 Nm  
Devir aralığı: 0,1 - 115 d/dak  
20 different sizes:  
Torque range: 5.000 - 470.000 Nm  
Speed range: 0,1 - 115 rpm  
20 verschiedene Baugrößen:  
Drehmomentber. :5.000-470.000 Nm  
Drehzahlbereich : 0,1-115 U/min



P ...

10 farklı büyüklükte;  
Moment aralığı: 1.000 - 50.000 Nm  
Tahvil oranları: 3,5 - 3000 arası  
10 different sizes:  
Torque range: 1.000 - 50.000 Nm  
Transmission ratio: 3,5 - 3000  
10 verschiedene Baugrößen:  
Drehmomentber. : 1.000 - 50.000 Nm  
Übersetzung: 3,5 - 3000



R ...

10 farklı büyüklükte;  
Moment aralığı: 1.000 - 50.000 Nm  
Tahvil oranları: 3,5 - 3000 arası  
10 different sizes:  
Torque range: 1.000 - 50.000 Nm  
Transmission ratio: 3,5 - 3000  
10 verschiedene Baugrößen:  
Drehmomentber. : 1.000 - 50.000 Nm  
Übersetzung: 3,5 - 3000



T ...

10 farklı büyüklükte;  
Moment aralığı: 200 - 18.000 Nm  
Devir aralığı: 46 - 280 d/dak  
10 different sizes:  
Torque range: 200-18.000 Nm  
Speed range: 46-280 rpm  
10 verschiedene Baugrößen:  
Drehmomentber. :200-18.000 Nm  
Drehzahlbereich : 46-280 U/min



VR ...

VR vinç redüktörleri  
M1 - M8 ,(1Dm - 5m) yük sınıfı  
ISO 4301 / 1 ,(FEM 1.001 / III)  
VR Hoist Drive Units  
M1 - M8 ,(1Dm - 5m) load classification  
ISO 4301 / 1 ,(FEM 1.001 / III)  
VR Kran und Hebezeug Getriebe  
M1 - M8 ,(1Dm - 5m) Belastungsart  
ISO 4301 / 1 ,(FEM 1.001 / III)



# Genel Bilgiler

## General Information

### Einführung



#### Y Serisi Redüktörlerin Genel Özellikleri

Y Serisi redüktörler, çok ağır şartlarda çalışmak üzere dizayn edilmiş redüktör tipleridir. Bu tiplerde redüktör ile bunu tahrik eden mekanizma arasında değişik bağlantı şekilleri mevcuttur (Mekanik ve hidrolik kaplinler, çeşitli tip kayışlar ve zincirle tahrik gibi). Bu tiplerin gövdesi ve kapağı yüksek kalite sfero dökümden, dişliler ise 21NiCrMo2 malzemeden imal edilerek yüzeyleri modern imalat üsülleri ile sertleştirilerek taşlanmaktadır. Mil dişli ve rulmanlı yatakların seçiminde yüksek ömür göz önünde tutulduğundan mukavemet değerleri ve emniyetleri yüksektir. Eksen aralıkları ISO'nun tavsiye ettiği aralıklara, mil delik ve kama ölçüleri de ISO standardına uygundur.

YILMAZ REDÜKTÖR olarak tasarım prensibimiz;

- Yüksek teknoloji kullanmak
- Güvenilirlik,
- Yüksek güç yoğunluğu,
- Yüksek verim,
- Montaj uyumluluğu,
- Esnek çözümler

#### Dikkat Edilecek Hususlar !

- Bu katalogta verilen resimler görsel amaçlıdır ve şekilsel detaylar bağlayıcı değildir.

- YILMAZ REDÜKTÖR, ürünler ve kataloglar üzerinde, müşterileri bilgilendirmeksizin her türlü değişikliği yapma hakkına sahiptir.

- Ürünler teslim alındıktan sonra ürünle birlikte verilen kullanım kılavuzu okunmadan sistem devreye alınmamalıdır.

- Katalogta verilen yağ miktarları referans amaçlıdır. Gerçek yağ seviyesi için redüktör üzerinde bulunan yağ seviye tapası kullanılmalıdır. Yağ viskozitesi için, redüktör etiketine bakınız.

- Sipariş anında montaj pozisyonu bildirilmeyen redüktörler M1 montajına uygun sevk edilir. Etiketle yazan montaj pozisyonundan farklı bağlanan redüktörler garanti kapsamından çıkar. Bu katalogta verilen redüktör ağırlıkları ortalama ağırlık değerleridir. Tahvil oranına ve üzerinde bağlı olan aksesuara göre ağırlıklar farklılık gösterebilir.

#### General Specifications of Y Series Gearboxes

*Y series gear units are designed for heavy duty applications. In this gear units have a lot of connection options available between gearbox and its actuation. (Mechanic and Hydraulic couplings, different kinds of belts and chain etc.) Gear unit housing and covers made of high quality spheroidal cast iron, gears made of 21NiCrMo2.*

*Our modern hardening process hardens their surfaces and they are either grounded or scraped to get high efficiency. Shaft, gears and bearings have high lifetimes. Centre distances are ISO advised values and all keyways, tapped centre holes are chosen according to ISO.*

*As we are YILMAZ REDÜKTÖR, our design principals are;*

- Using high technology
- Reliability
- High power density
- High efficiency
- Mounting compatible
- Flexible solutions

#### Attention to the following points !

*- Drawings are examples only and the details on the drawings or illustrations are not strictly binding.*

*- YILMAZ REDÜKTÖR reserve the right to make all kinds of changes in products and catalogues without any notice.*

*- Prior to commissioning, the operating instructions provided with the gearbox must be observed.*

*- Oil quantities given are guide values only. The exact quantity of oil should be checked by using the provided oil level plugs according mounting positions. For correct oil viscosity refer to the nameplate.*

*- If the mounting position is not informed upon ordering, the gear unit is delivered according M1 mounting position. A different operation than the indicated mounting position on the name plate cancels the warranty. The weights given in this catalogue are mean values. Depending on the ratio and accessories the weights can differ.*

#### Allgemeine Eigenschaften von Y Serie Getrieben

Bei dieser Ausführung gibt es sehr viele Verschiedene ferbindungs möglichkeiten zwischen Betrieb und Getriebe (Zum Beispiel, Mechanische und Hydrolische Kupplungen, Riementrieb, Kettentrieb usw.). Das Gähause und der Deckel ist aus Gusseisen hoher Qualität. Die Zahnräder sind aus 21NiCrMo2 gefertigt und sind in unseren modernen Anlagen gehärtet und geschlifen dadurch wird ein hoher Wirkungsgrad erzielt. Wellen und Wälzlagern sind sehr sorgfältig ausgewählt für hohe Festigkeit und lange Lebensdauer. Achsabstände sind entsprechend ISO passend ausgewählt. Alle Wellen, Keile und Zentrierungen sind nach ISO.

Als YILMAZ REDÜKTÖR unsere Entwurfsprinzipien sind;

- Verwenden von hohen Fertigungstechn.
- Hohe Betriebssicherheit
- Leistungsdichte
- Hoher Wirkungsgrad
- Universale Montagemöglichkeit
- Sonderlösungen

#### Bitte folgende Punkte beachten !

- Die Abbildungen sind beispielhaft und nicht verbindlich.

- Alle Änderungen auf dem Katalog und an der Produkte bleiben vorbehalten und können ohne Kenntnisnahme erfolgen.

- Vor Inbetriebnahme ist die mit gelieferter Betriebsanleitung zu beachten.

-Angaben über Ölmengen sind unverbindlich. Maßgebend ist die Ölstandsschraube in der geeigneten Montageposition. Ölviskosität und Sorte muss den Angaben des Typenschildes entsprechen.

- Wenn die Bauform bei Bestellung nicht angegeben ist, erfolgt die Lieferung in der Bauform M1. Wenn die Getriebe anders als auf dem Typenschild benannte Bauform eingesetzt werden, verliert die Garantie ihre Gültigkeit. Die angegebenen Gewichte sind unverbindliche Mittelwerte ohne Zubehör; genauere Gewichte sind abhängig von Zubehör und Übersetzung.



# Genel Bilgiler

## General Information

### Einführung



#### Teknik Tanımlamalar

##### - Çıkış Momenti ( $M_2$ ): [Nm]

Motorun verdiği momentin tahvil oranı ve verimle ile çarpılarak elde edilen değerdir. Redüktörün çıkışından alınabilecek moment gösterir.

##### - Anma Momenti ( $M_a$ ): [Nm]

Redüktörün  $f_s=1$  şartı için mekanik olarak taşıdığı moment değeridir.

##### - Nominal Güç ( $P_n$ ): [kW]

Nominal güç, redüktörün  $f_s=1$  şartı için mekanik olarak taşıyabileceği güç değeridir. Redüktörlerin nominal güçleri, güç devir tablolarında verilmiştir.

##### - Çevrim oranı (i):

Redüktörün giriş devrinin çıkış devrine oranıdır. Yılmaz Redüktör Y serisi redüktörlerde 1,4-529,66 arasında değişen çevrim oranları mevcuttur.

##### - Eşdeğer Güç ve Moment

###### $P_{eq}$ [kW], $T_o$ [Nm]

Sabit devir altında ancak değişken yük değerlerinde çalışan redüktörlerde, sabit yük altında çalışma şartlarına eşdeğer gelen moment ve güç değerleridir. Hesaplama yöntemi sayfa 23'de verilmiştir.

##### - İhtiyaç güç ( $P_m$ ): [kW]

Redüktörlerin kullanılacağı uygulamanın istenilen şekilde çalışabilmesi için ihtiyaç duyduğu güç değeridir.

##### - İhtiyaç moment (T): [Nm]

Redüktörün kullanılacağı uygulamanın çalışabilmesi için ihtiyaç duyduğu moment değeridir. Seçilen redüktör için her zaman çıkış momentine eşit yada daha düşük olmalıdır.

##### - Müsade Edilen Eksenel ve Radyal Yükler

###### Fqem, Fqam [N]

Redüktörün giriş veya çıkış milinde müsade edilen eksenel ve radyal yüklerdir.

##### - Servis Faktörü ( $f_s$ ):

Redüktörün çalıştığı şartlar ile uyumlu olması için gerekli olan emniyet katsayısıdır.  $f_s=1$ , düzgün ve sakin yüklerde, günlük sekiz saat, saatte 100 dur-kalk çalışmayı karşılar. Detaylar için redüktör seçim bölümüne bakınız.

#### Teknik Özellikler:

##### - Ses seviyesi:

Redüktörlerimizin ses seviyesi VDI 2159' da verilen redüktörler için müsade edilen ses seviyelerinin altındadır.

##### - Yağlama:

Y Serisi redüktörler yağlama tablolarında verilen yağlar ile doldurulmaktadır. Yağ detayları için yağlama bölümüne bakınız.

#### Technical Explanations

##### - Output Torque ( $M_2$ ): [Nm]

Multiplication of motor output torque with transmission ratio and efficiency gives the result of output torque at the output shaft of the gear unit.

##### - Nominal Torque ( $M_a$ ): [Nm]

Nominal torque is the mechanical torque which the gearbox can resist under  $f_s=1$  conditions.

##### - Nominal Power ( $P_n$ ): [kW]

The nominal power is the power which gearbox can mechanically resist under  $f_s=1$  condition. The nominal powers are given on the performance tables.

##### - Ratio (i):

Ratio between output shaft speed and input shaft speed. Available ratios of Yılmaz Redüktör Y series are between 1,4 to 529,66.

##### - Equivalent Power and Torque

###### $P_{eq}$ [kW], $T_o$ [Nm]

For gearbox unit with constant speed but variable working conditions : This is the calculated power or torque which is equivalent to the values at working under constant working conditions.

##### - Required Power ( $P_m$ ): [kW]

Required power for the applications which is able to drive the system.

##### - Required Torque (T): [Nm]

Required torque for applications. Required torque always must be equal or smaller than output torque for selected gearbox.

##### - Permissible Axial and Overhung Loads:

###### Fqem, Fqam [N]

Permissible axial and overhung load at the output or input shaft of gearboxes.

##### - Service Factor ( $f_s$ ):

Service factor is a safety coefficient, which takes into account the different running conditions of the driven machine.  $f_s=1$  is used for uniform loads 8 hours working per day and up to 100 cycle per hour.

#### Technical Specifications:

##### - Noise Level:

The noise level of our gearboxes is below the permitted values defined in VDI guidelines 2159 for gear units.

##### - Lubrication:

Y series of gearboxes filled with oils which is indicated on lubrication tables. For lubrication details please refer to the lubrication section.

#### Technische Erläuterungen

##### - Ausgangsmoment ( $M_2$ ): [Nm]

Multiplikation von Ausgangsmoment des Motors mit Übersetzung und Division das Ergebnis mit Wirkungsgrad ergibt den Betrag von Ausgangsmoment der Getriebe.

##### - Nennmoment ( $M_a$ ): [Nm]

Mechanisches Belastungsmoment der Getriebe unter dem Bedingung  $f_s=1$ .

##### - Nennleistung ( $P_n$ ): [kW]

Die Nennleistung ist die mechanische Grenzfestigkeitsleistung für  $f_s=1$ . Kann von der Leistung-Drehzahltafel abgelesen werden.

##### - Übersetzung (i):

Wird aus dem Verhältnis von Ausgang- zu Eingangswinkelgeschwindigkeit bestimmt. Gängige Übersetzungen von Yılmaz Y Serie Getriebe liegt zwischen 1,4 bis 529,66.

##### - Äquivalente Leistung und Moment

###### $P_{eq}$ [kW], $T_o$ [Nm]

Für mit konstanten Drehzahl aber unter veränderlichen Betriebsbedingungen arbeitende Getriebe berechnete Leistung und Moment äquivalent zu Werten beim Arbeiten unter konstanten Betriebsbedingungen.

##### - Notwendige Leistung ( $P_m$ ): [kW]

Für das Getriebe notwendige Leistung, um Arbeiten von Getriebe bei der für das Getriebe gedachten Anwendung zu gewährleisten.

##### - Notwendige Moment (T): [Nm]

Notwendige Moment für Anwendungen. Für den ausgewählte Getriebe soll das notwendige Moment gleich dem Ausgangsmoment oder kleiner als diesem Moment sein.

##### - Zulässige Axial- oder Querkräfte:

###### Fqem, Fqam [N]

Bei der Anwendungen während der Betrieb zulässige axiale oder radiale Eingangs- oder Ausgangsbelastungen.

##### - Betriebsfaktor ( $f_s$ ):

Dieser Faktor  $f_s$  ist ein Sicherheitsfaktor, damit die Getriebe unter verschiedenen Bedingungen mit genügender Sicherheit arbeitet.  $f_s=1$  gilt für gleichförmig Belastung, mit 8 Betriebsstunden pro Tag und bis zum 100 Schaltungen pro Stunde.

#### Technische Informationen:

##### - Geräuschpegel:

Geräuschstärken aller Getriebe bleiben unter die zulässigen Werte, die für die Getriebe in der VDI-Richtlinie 2159 festgelegt sind.

##### - Schmierung:

Y Serie Getriebe werden mit Ölen entsprechend der Schmierungstabellen, falls nicht anders vereinbart, geliefert. Für weitere Schmierungsangaben siehe Kapitel Schmierung.





# Genel Bilgiler General Information Einführung



## - Aksesuarlar:

Y Serisi redüktörlerde aşağıdaki aksesuarlar kullanılabilir

- Sıkma bileziği
- Geri dönüş kilidi
- Özel keçe çözümleri,
- Cam yağ seviye göstergesi
- Elektromanyetik frenler

Diğer özel aksesuarlar için lütfen, YILMAZ REDÜKTÖR ile temasa geçiniz.

## - Yüzey Koruması

Redüktörlerimiz aksi belirtilmedikçe boyalı olarak sevk edilmektedir. DIN EN ISO 12944-2 korozyon standardında belirtilen sınıflardan aşağıdaki tabloda belirtilen 4 kategori için yüzey koruması sağlanmaktadır. Standart boya sınıfımız C2 korozyon kategorisini karşılamaktadır. Farklı bir koruma sınıfı istenirse sipariş aşamasında belirtilmelidir. Mil, flanş bağlantı yüzeyi gibi boyanmayan yüzeylere paslanmaya karşı koruma sağlamak için korozyon önleyici yağ sürülmektedir.

## - Accessories:

The following accessories can be applied to Y series gearboxes.

- Shrink Discs
- Backstops
- Special sealing solutions.
- Glass oil level indicator,
- Electromagnetic brakes.

For other accessories please contact, YILMAZ REDÜKTÖR.

## - Surface Protection

Our products are all painted unless otherwise stated. 4 corrosion categories which are mentioned below can be offered according to corrosion categories of DIN EN ISO 12944-2 standard. Our standard paint meets C2 corrosion category. If different category is requested, please inform before order. Unpainted parts such as shaft, flange connection surface are coated with anti-corrosion paint before shipment against corrosion.

## - Zubehör:

Folgendes Zubehör kann für Getriebe der Y Serie geliefert werden.

- Schrumpfscheiben
- Rücklaufperren
- Unterschiedliche Dichtungssysteme
- Ölstandsanzeige aus Glas
- Elektromagnetische Bremsen

Für weiteres Zubehör kontaktieren Sie bitte mit, YILMAZ REDÜKTÖR.

## - Oberflächenschutz

Getriebe von Yılmaz Redüktör werden lackiert und so geliefert falls nicht anders vereinbart ist. Die 4 untenstehenden Korrosionskategorien können nach Korrosionsschutz-Basisnorm DIN EN ISO 12944-2 angeboten werden. Unsere Standard-Lackierung erfüllt C2-Korrosionskategorie. Wenn Sie eine andere Kategorie erwünschen, informieren Sie uns bitte darüber vor der Bestellung. Nicht lackierte Teile (z.B. Welle, Oberfläche des Anschlussflanschs) werden mit einem Schutzmittel vor dem Versand geschmiert, um vor Korrosion und Rost zu schützen.

Korozyon Kategorisi Corrosion Categories Korrosivitätskategorie	Çevre Şartları Ambient Conditions Umgebungsbedingungen	Boya Tipi Paint Type Lackierung	Boya Kalınlıkları Paint Thickness Sollschichtdicke
C2 (Standard)	<b>İç ortam ve muhafazalı dış ortam Nem ve kirlilik oranı düşük çalışma ortamı</b> Indoor installation and outdoor installation with protection roof Environments with low humidity and contamination Innenaufstellung und Außenaufstellung mit Überdachung oder Schutzeinrichtung Atmosphäre mit niedriger Luftfeuchtigkeit und Verunreinigung	<b>Çift Komponent Astar</b> Two-Component Primer Coat Zwei-Komponenten Grundierung <b>Akrilik Sonkat</b> Acrylic Top Coat Akryl-Decklack	60 µm 40 µm
C3	<b>İç ortam ve atmosfere açık dış ortam Orta seviyede nem ve kirlilik olan çalışma ortamı</b> Indoor installation and outdoor installation subject to weathering Environments with mean humidity and contamination Innenaufstellung und Außenaufstellung im Freien unter Bewitterung Atmosphäre mit mäßiger Luftfeuchtigkeit und Verunreinigung	<b>Epoksi Astar</b> Epoxy Primer Coat Epoxy-Grundierung <b>Akrilik Sonkat</b> Acrylic Top Coat Akryl-Decklack	80 µm 40 µm
C4	<b>İç ortam ve atmosfere açık dış ortam Genelde yüksek nem ve kimyasal madde olan çalışma ortamı</b> Indoor installation and outdoor installation subject to weathering Environments with occasionally high humidity and chemical contamination Innenaufstellung und Außenaufstellung im Freien unter Bewitterung Atmosphäre gelegentlich mit hoher Luftfeuchtigkeit und chemischer Verunreinigung	<b>Epoksi Astar</b> Epoxy Primer Coat Epoxy-Grundierung <b>Akrilik Sonkat</b> Acrylic Top Coat Akryl-Decklack	180 µm 40 µm
C5-I / C5-M	<b>İç ortam ve atmosfere açık dış ortam Sürekli yüksek nem ve kimyasal madde ile temizlik yapılan çalışma ortamı</b> Indoor installation and outdoor installation subject to weathering Environments with permanent high humidity and chemical cleaning contamination Innenaufstellung und Außenaufstellung im Freien unter Bewitterung Atmosphäre mit ständiger hoher Luftfeuchtigkeit und chemischer Verunreinigung (Nassreinigung mit Säuren/Laugen und auch mit chemischen Reinigungsmitteln).	<b>Çinko Yükleli Epoksi Astar</b> Epoxy Zinc Primer Coat Epoxy-Zink-Grundierung <b>Epoksi Astar Miox</b> Epoxy Miox Primer Coat Epoxy-Miox-Grundierung <b>Akrilik Sonkat</b> Acrylic Top Coat Akryl-Decklack	70 µm 150 µm 40 µm



**Genel Bilgiler**  
*General Information*  
Einführung







# Genel Bilgiler

## General Information

### Einführung



Tip Tanımlaması / Unit Designation / Typenbezeichnung

**YR M - 3-705 - L**

Tertip / Arrangements / Anordnung

- L-** Sağ Giriş Sol Çıkış / Right Input Shaft, Left Output Shaft / Rechtsseitiger Antrieb, Linksseitiger Abtrieb
- R-** Sol Giriş Sağ Çıkış / Left Input Shaft, Right Output Shaft / Linksseitiger Antrieb, Rechtsseitiger Abtrieb
- UL-** Sol Giriş Sol Çıkış / Left Input Shaft, Left Output Shaft / Linksseitiger Antrieb, Linksseitiger Abtrieb
- UR-** Sağ Giriş Sağ Çıkış / Right Input Shaft, Right Output Shaft / Rechtsseitiger Antrieb, Rechtsseitiger Abtrieb
- LW-** Çift Giriş Milli, Sol Çıkış / Double Input Shaft, Left Output Shaft / Beidseitiger Antrieb, Linksseitiger Abtrieb
- RW-** Çift Giriş Milli, Sağ Çıkış / Double Input Shaft, Right Output Shaft / Beidseitiger Antrieb, Rechtsseitiger Abtrieb
- CL-** Sağ Giriş Milli, Çift Çıkış Milli / Right Input Shaft, Double Output Shaft / Rechtsseitiger Antrieb, Beidseitiger Abtrieb
- CR-** Sol Giriş Milli, Çift Çıkış Milli / Left Input Shaft, Double Output Shaft / Linksseitiger Antrieb, Beidseitiger Abtrieb
- CW-** Çift Giriş Milli, Çift Çıkış Milli / Double Input Shaft, Double Output / Beidseitiger Antrieb, Beidseitiger Abtrieb
- DL-** Sağ Giriş Milli, Delik Milli Çıkış / Right Input Shaft, Hollow Shaft Output / Rechtsseitiger Antrieb, Hohlwellenabtrieb
- DR-** Sol Giriş Milli, Delik Milli Çıkış / Left Input Shaft, Hollow Shaft Output / Linksseitiger Antrieb, Hohlwellenabtrieb
- DW-** Çift Giriş Milli, Delik Milli Çıkış / Double Input Shaft, Hollow Shaft Output / Beidseitiger Antrieb, Hohlwellenabtrieb
- RE-** Sol Giriş Milli, Extruder Çıkış Milli / Left Input Shaft, Extruder Output / Linksseitiger Antrieb, Extruder Abtriebswelle

Eksen Arası Mesafe / Axis Distances / Achsabstand

Kademe Sayısı / Stage / Anzahl der Stufen

1...4

Çıkış Mili Özelliği / Output Shaft / Eigenschaft der Ausgangswelle

- M** :Çıkış Milli / Solid Shaft / Vollwelle
- C** :Çift Çıkış Milli / Double Solid Shaft / Mit doppelter Abtriebswelle
- D** :Delik milli / Hollow Shaft / Hohlwelle
- E** :Extruder Milli / Extruder Typ Output / Extruder-Ausgang

Redüktör Tipi / Gearbox Type / Getriebe

YR Serisi / YR Serie / YR Serie

Tip Tanımlaması / Unit Designation / Typenbezeichnungen

- YRM..** Yatık tip motorsuz redüktörler, mil çıkışlı / Horizontal type geared units with solid output shaft / Horizontal Typ Getriebe mit Abtriebswelle.
- YRD..** Yatık tip motorsuz redüktörler, delik milli çıkış / Horizontal type geared units with hollow output shaft / Horizontal Typ Getriebe, Ausgang mit Hohlwelle.
- YRC..** Yatık tip motorsuz redüktörler, çift mil çıkışlı / Horizontal type geared units with double solid output shaft / Horizontal Typ Getriebe mit doppelter Abtriebswelle.
- YRE..** Yatık tip motorsuz redüktörler, Extruder tipi / Horizontal type geared units , extruder typ / Horizontal Typ Getriebe, Extruderausführung.



# Genel Bilgiler

## General Information

### Einführung



#### Mil Pozisyonları / Shaft Arrangements / Wellen Positionen

	<p><b>YRM....□:</b> Yatık tip motorsuz redüktörler, mil çıkışlı <i>Horizontal type geared units with solid output shaft</i> Horizontal Typ Getriebe mit Abtriebswelle</p> <p>L R UL UR LW RW</p>
	<p><b>YRC....□:</b> Yatık tip motorsuz redüktörler, çift mil çıkışlı <i>Horizontal type geared units with double solid output shaft</i> Horizontal Typ Getriebe mit doppelter Abtriebswelle</p> <p>CL CR CW</p>
	<p><b>YRD....□:</b> Yatık tip motorsuz redüktörler, delik milli çıkışlı <i>Horizontal type geared units with hollow output shaft</i> Horizontal Typ Getriebe, Aufsteckausführung</p> <p>DL DR DW</p>
	<p><b>YRE....□:</b> Yatık tip motorsuz redüktörler, Extruder tipi <i>Horizontal type geared units, Extruder typ</i> Horizontal Typ Getriebe, Extruderausführung</p> <p>RE</p>



# Genel Bilgiler

## General Information

### Einführung



#### Redüktör Dönüş Yönleri

Y Serisi ürünlerimiz için kullanılan yön tanımlaması aşağıdaki gibidir. Aşağıdaki tanımlama kilitli redüktörler için de geçerlidir.

#### Direction of Rotation

Y Series direction of rotation of Yılmaz products are defined as follows. The definitions are also valid for gear units with backstop.

#### Getriebedrehrichtungen

Die Drehrichtungen für Y Serie Getriebe sind wie folgt definiert. Die Definition ist auch bei Getrieben mit Rücklauf Sperre gültig.

	1-3-5 Kademe / 1-3-5 Stages / 1-3-5 Stufig	2-4 Kademe / 2-4 Stages / 2-4 Stufig
<b>Saat Yönünde</b> Clockwise im Uhrzeigersinn <b>CW</b>		
<b>Saat Tersi Yönünde</b> Counter Clockwise gegen Uhrzeigersinn <b>CCW</b>		

Giriş mili dönüş yönüne göre çıkış mili dönüş yönleri aşağıdaki gibidir.

Output shaft rotation directions according to the input shaft rotation directions are as follows.

Drehrichtungen der Abtriebswelle in Abhängigkeit von den Antriebswellen sind wie folgt;

1-3-5 Kademe / 1-3-5 Stages / 1-3-5 Stufig	2-4 kademe / 2-4 Stages / 2-4 Stufig



# Genel Bilgiler

## General Information

### Einführung



#### Servis Faktörü

Servis faktörü (fs) redüktörün çalıştığı şartlar ile uyumlu olması için gerekli olan emniyet katsayısıdır. "fs =1" Düzgün ve sakin yüklerde, günlük sekiz saat ve saatte yüz start çalışmayı karşılar.

Aşağıdaki etkenlere bağlıdır:

- Günlük çalışma süresi
- Yük sınıfı
- Bir saatteki start sayısı
- Redüktör tahrik tipi
- Diğer gözlemler

Bu etkenleri göz önüne aldığımızda, gerekli servis faktörünü belirlemek için:

1. Makinanın günlük çalışma süresini tespit ediniz.
2. Makinanın ne türde yükler verdiğini tespit ediniz (Sayfa 17-18 ).

- U - Düzgün ve sabit yükler
- M - Orta darbeli yükler
- H - Ağır darbeli yükler

Yük sınıfının daha teknik seçimi için rotora indirgenmiş toplam atalet momenti formülünden faydalanabilirsiniz (Sayfa 20).

3. Saatteki start sayısını tespit ediniz.
4. İlk üç maddeye bağlı servis faktörünü aşağıdaki tablodan seçiniz.

5. fs Redüktörümüzün tahrik tipine bağlı olarak "k" katsayısı ile çarpılarak artırılır.

- k=1 :Elektrik motoru veya hidromotor  
k=1.25 :İçten yanmalı çok silindirli motor  
k=1.5 :İçten yanmalı tek silindirli motor

#### Service Factor

Service Factor (fs) is a safety coefficient, which takes into account the different running conditions of the driven machine. "fs=1" is used for uniform loads 8 hours working per day and up to 100 starts per hour.

Service factor depends on:

- Running time
- Nature of load
- Frequency of starting
- Driver type
- Other considerations

For the right selection of the needed service factor for your machine;

1. Determine the running time of driven machine.
2. Select the nature of load of driven machine (Page 17-18).

- U - Uniform loads
- M - Moderate loads
- H - Heavy shock loads

For a better selection, the nature of load can be calculated from the formulas given (page 20).

3. Determine frequency of starting
4. After determining the above mentioned factors, the service factor can be easily selected from the table given below.
5. The selected service factor must be multiplied with the factor "k" according to the driver type;

- k=1 :Electric motor or Hydraulic motor  
k=1.25 :Multicylinder internal combustion engine  
k=1.5 :Single cylinder internal combustion engine

#### Betriebsfaktor

Der Betriebsfaktor (fs) ist ein Sicherheitsfaktor für die Getriebe, damit sie unter den Betriebsbedingungen sicher arbeiten. "fs =1" steht für gleichförmige Belastung, 8 Stunden pro Tag und bis zu 100 Schaltungen pro Stunde.

Betriebsfaktor ist abhängig von:

- Betriebsdauer
- Belastungsart
- Schalthäufigkeit
- Antriebsart
- Andere Faktoren

Um die richtigen Betriebsfaktor festzulegen;

1. Betriebsdauer der angetriebenen Maschine bestimmen.
2. Belastungsart der angetriebenen Maschine auswählen.

- U - Gleichförmige Belastung
- M - Ungleichförmige Belastung
- H - Stark Ungleichförmige Belastung

Um eine bessere Auswahl zu treffen, können die Belastungsarten mit den angegebenen Formeln (Seite 20) errechnet werden.

3. Schalthäufigkeit bestimmen.
4. Nach Bestimmen der oben angegebenen Werte, können die Betriebsfaktoren von der unten stehenden Tabelle entnommen werden.
5. Der ausgewählte Betriebsfaktor muß mit dem Faktor "k" abhängig von der Antriebsart multipliziert werden

- k=1 :Elektromotor oder Hydraulikmotor  
k=1.25 :Vielzylindermotor  
k=1.5 :Einzyldermotor

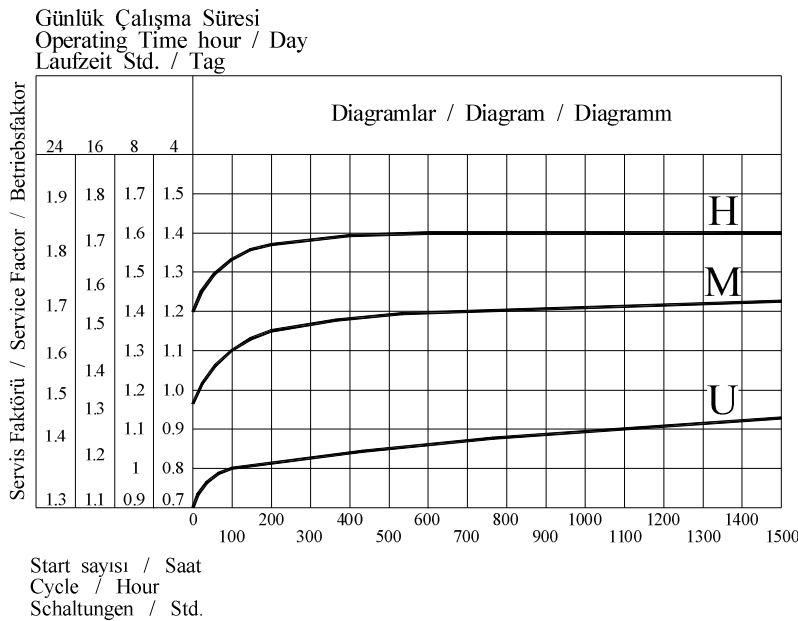



# Genel Bilgiler

## General Information

### Einführung



Günlük Çalışma Saati Operating per Day (h) Laufzeit pro Tag (Std)	Yük sınıfı Nature of Load Belastungsart	Service Faktörü $f_s$ / Service Factor $f_s$ / Betriebsfaktor $f_s$							
		Saatte Start Sayısı / Cycles per Hour / Schaltungen pro Stunde							
		0 - 50	50 - 100	100 - 200	200 - 300	300 - 500	500 - 700	700 - 1000	1000-1500
< 4	U	0,75	0,8	0,8	0,85	0,85	0,85	0,9	0,95
	M	1,05	1,1	1,15	1,15	1,2	1,2	1,2	1,2
	H	1,3	1,35	1,35	1,4	1,4	1,4	1,4	1,4
4 - 8	U	0,95	1,0	1,0	1,05	1,05	1,1	1,1	1,1
	M	1,25	1,3	1,35	1,4	1,4	1,4	1,4	1,45
	H	1,5	1,55	1,6	1,6	1,6	1,6	1,6	1,6
8 - 16	U	1,1	1,2	1,2	1,2	1,2	1,25	1,3	1,3
	M	1,4	1,45	1,5	1,5	1,5	1,55	1,55	1,55
	H	1,6	1,65	1,7	1,7	1,7	1,7	1,7	1,7
> 16	U	1,35	1,4	1,4	1,4	1,4	1,4	1,4	1,4
	M	1,55	1,6	1,65	1,7	1,7	1,7	1,7	1,75
	H	1,8	1,8	1,8	1,8	1,85	1,85	1,9	2,0

$J_{ext}$ -----:Motor miline indirgenmiş dış atalet momenti External moments of inertia reduced on motor shaft Externe Massenträgheitsmomente reduziert auf Motorwelle	$J'_{ext} = \frac{J_{ext}}{i^2}$
$i$ -----:Tahvil oranı Transmission ratio Übersetzung	
$J_{rotor}$ -----:Motorun atalet momenti Torque of inertia of the motor Massenträgheitsmoment des Antriebsmotors	$F_i = \frac{J'_{ext}}{J_{rotor}}$

U	Uniform Yük Uniform Loads Gleichförmige Last	$F_i < 0,25$
M	Orta Darbeli Yük Moderate Loads Ungleichförmige Last	$F_i < 3$
H	Darbeli Yük Heavy Shock Loads Stark Ungleichförmige Last	$F_i < 10$

Tahrik Makinası Faktörü $k_1$	
Elektrik motorları, Hidromotorlar, Türbinler	1
İçten yanmalı motorlar, 4 ve 4den fazla silindirli	1,25
İçten yanmalı motorlar, 1-3 silindirli	1,5

Driving Machine Factor $k_1$	
Electric motors, Hydraulic motors, Turbines	1
Piston Engines 4 or more than 4 cylinders	1,25
Piston Engines 1 to 3 cylinders	1,5

Antriebsmaschinen-Faktor $k_1$	
Elektromotoren, Hydromotoren, Turbinen	1
Kolbenmaschinen, 4 oder mehr Zylinder	1,25
Kolbenmaschinen, 1 bis 3 Zylinder	1,5

Pik Moment Faktörü $k_2$				
	Saatteki Pik Moment Adedi			
	1-5	6-30	31-100	>100
Aynı yönlü moment	0,5	0,65	0,7	0,85
Değişken yönlü moment	0,7	0,95	1,1	1,25

Peak Torque Factor $k_2$				
	Load peaks per hour			
	1-5	6-30	31-100	>100
Steady direction load	0,5	0,65	0,7	0,85
Alternating direction load	0,7	0,95	1,1	1,25

Spitzenmoment-Faktor $k_2$				
	Belastungsspitzen pro Stunde			
	1-5	6-30	31-100	>100
Gleichbleibende Lastrichtung	0,5	0,65	0,7	0,85
Wechselnde Lastrichtung	0,7	0,95	1,1	1,25

Soğuma Faktörü $t_1$				
Saatte Çalışma Yüzdesi [ ED ] %				
100	80	60	40	20
1,00	1,06	1,16	1,35	1,79

Cooling Factor $t_1$				
Operation cycle per hour [ ED ] in %				
100	80	60	40	20
1,00	1,06	1,16	1,35	1,79

Kühlungs-Faktor $t_1$				
Einschaltdauer je Stunde [ ED ] in %				
100	80	60	40	20
1,00	1,06	1,16	1,35	1,79





# Genel Bilgiler

## General Information

### Einführung



Yükseklik Faktörü $t_2$				
Soğutmasız veya fanlı soğutmalı				
Deniz seviyesinden yükseklik [m]				
<1000	<2000	<3000	<4000	<5000
1,00	0,95	0,90	0,85	0,80

Factor for Altitude $t_2$				
Without auxiliary cooling or with fan cooling				
Altitude above MSL [m]				
<1000	<2000	<3000	<4000	<5000
1,00	0,95	0,90	0,85	0,80

Höhen-Faktor $t_2$				
Ohne Zusatzkühlung oder mit Lüfterkühlung				
Höhenlage über NN [m]				
<1000	<2000	<3000	<4000	<5000
1,00	0,95	0,90	0,85	0,80

Yükseklik Faktörü $t_3$				
Serpantinli veya eşanjörlü soğutmalı				
Deniz seviyesinden yükseklik [m]				
<1000	<2000	<3000	<4000	<5000
1,00	0,98	0,96	0,94	0,92

Factor for altitude $t_3$				
With cooling coil or heat exchanger				
Altitude above MSL [m]				
<1000	<2000	<3000	<4000	<5000
1,00	0,98	0,96	0,94	0,92

Höhen-Faktor $t_3$				
Kühlung durch Kühlschlange / Wärmetauscher				
Höhenlage über NN [m]				
<1000	<2000	<3000	<4000	<5000
1,00	0,98	0,96	0,94	0,92

Yağlama Faktörü $t_4$			
Montaj Pozisyonu	Daldırma Yağlama	Genleşme Tankı	Basınçlı Yağlama
M1 / M3	1,00	-	1,05
M5 / M6	-	0,92	1,00
M2 / M4	0,95	0,92	0,95

Lubrication Factor $t_4$			
Mounting Position	Dip Lubrication	Expansion Tank	Forced Lubrication
M1 / M3	1,00	-	1,05
M5 / M6	-	0,92	1,00
M2 / M4	0,95	0,92	0,95

Schmierungs-Faktor $t_4$			
Bauform	Tauchschnierung	Öläusgleichbehälter	Druckschnierung
M1 / M3	1,00	-	1,05
M5 / M6	-	0,92	1,00
M2 / M4	0,95	0,92	0,95

Hava Hızı Faktörü $t_5$					
Soğutucu Türü	Çevre Hava Hızı [m / sn]				
	0,5	1,25	1,5	2	4
Soğutmasız	0,74	1,0	1,13	1,26	1,84
Fanlı	0,94	1,0	1,02	1,06	1,16
Serpantinli / Eşanjörlü	0,9	1,0	1,05	1,1	1,32
Fanlı ve Serpantinli	0,97	1,0	1,01	1,03	1,09

Wind Velocity Factor $t_5$					
Cooling System	Wind Velocity [m / s]				
	0,5	1,25	1,5	2	4
Without Cooling	0,74	1,0	1,13	1,26	1,84
With Fan	0,94	1,0	1,02	1,06	1,16
With cooling coil / Heat exchanger	0,9	1,0	1,05	1,1	1,32
With Fan / Cooling coil	0,97	1,0	1,01	1,03	1,09

Windgeschwindigkeitsfaktor $t_5$					
Kühlung System	Windgeschwindigkeit [m / sn]				
	0,5	1,25	1,5	2	4
Ohne Kühlung	0,74	1,0	1,13	1,26	1,84
Mit Lüfter	0,94	1,0	1,02	1,06	1,16
Mit Kühlschlange / Wärmetauscher	0,9	1,0	1,05	1,1	1,32
Mit Lüfter / Kühlschlange	0,97	1,0	1,01	1,03	1,09

Çevre Sıcaklığı Faktörü $t_6$		
Ortam Sıcaklığı [°C]		
20°C	30°C	40°C
1,00	0,81	0,68

Environment Temperature Factor $t_6$		
Environment Temperature [°C]		
20°C	30°C	40°C
1,00	0,81	0,68

Umgebungstemperaturfaktor $t_6$		
Umgebungstemperatur [°C]		
20°C	30°C	40°C
1,00	0,81	0,68



# Genel Bilgiler

## General Information

### Einführung



Önerilen Servis Faktörleri Recommended Service Factors Empfehlung für Betriebsfaktoren				Günlük Çalışma Saati Operation time per day Betriebsstunden pro Tag			
				h<4	4 - 8	8 - 16	h>16
Kimya Sektörü Chemical Industry Chemische Industrie	<b>Sıvı Karıştırıcılar</b> M-Sabit yoğunluklu sıvı M-Değişken yoğunluklu sıvı H-Değişken gaz oranları	<b>Agitators</b> M-Uniform solid media M-None-uniform solid media H-None-uniform gas absorption	<b>Rührwerke</b> M-Gleichmäßige Dichte M-Ungleichmäßige Dichte H-Ungleichmäßige Begasung	1,0 1,2 1,4	1,3 1,5 1,6	1,4 1,6 1,7	1,5 1,7 1,8
	<b>Katı Karıştırıcılar</b> M-Eşit taneli katı H-Değişken taneli katı M-Beton	<b>Mixers</b> M-Constant density liquid H-Variable density liquid M-Concrete	<b>Mischer</b> M-Gleichmäßiges Gut H-Ungleichmäßiges Gut M-Beton	1,3 1,4 1,5	1,4 1,6 1,5	1,5 1,7 1,5	1,6 1,8 1,6
	<b>Kauçuk ve Plastik Makinaları</b> M-Plastik extruderler H-Kauçuk extruder H-Kauçuk hadde (2' li) H-Kauçuk hadde (3' lü) H-Isıtıcı hadde H-Kalender H-Taşlama H-Karıştırıcı hadde H-Düzlemselleştirme H-Inceltme	<b>Rubber and Plastic Machines</b> M-Plastic extruders H-Rubber extruders H-Rubber mills (2' in a row ) H-Rubber mills (3' in a row ) H-Warming mills H-Calenders H-Grinders H-Mixing mills H-Sheeters H-Refiners	<b>Gummi und Kunststoff Maschinen</b> M-Kunststoff Extruder H-Gummi Extruder H-Gummi Wälzwerke (2 Walzen) H-Gummi Wälzwerke (3 Walzen) H-Wärmestrommel H-Gummikalender H-Schleifen H-Kalender Mischer H-Flach Walzen H-Fein Walzen	1,4 1,5 1,6 1,5 1,4 1,7 1,6 1,6 1,6 1,6	1,4 1,5 1,8 1,5 1,5 1,7 1,8 1,8 1,8	1,5 1,6 1,8 1,6 1,6 1,7 1,8 1,8 1,8	1,6 1,8 2,0 1,8 1,8 1,7 2,0 2,0 2,0
	<b>Atık Su Arıtma</b> U-Kalınlaştırıcı (Merkez Tahrikli) U-Filtre presleri U-Çamur karıştırıcı H-Dairesel havalandırıcı H-Fırçalı havalandırıcı U-Dairesel tarama U-Dairesel ve doğrusal tarama U-Ön kalınlaştırıcı M-Vidalı pompa H-Su türbinleri	<b>Waste Water Treatment</b> U-Thickeners (central drive) U-Filter presses U-Flocculation agitator H-Circular aerators H-Brush aerators U-Raking Equipment U-Longitudinal and rotary rakes U-Pre-thickeners M-Screw pumps H-Water turbines	<b>Abwasser</b> U-Eindicker (Zentralantrieb) U-Filterpressen U-Flockungsrührer H-Kreisellüfter H-Bürstenbelüfter U-Rechenanlagen U-Rund und Längsräumen U-Voreindicker M-Schneckenpumpen H-Wasserturbinen	1,2 1,2 1,0 1,8 2,0 1,0 1,1 1,2 1,3 2,0	1,3 1,3 1,2 1,8 2,0 1,2 1,3 1,5 2,0	1,4 1,4 1,2 1,8 2,0 1,2 1,3 1,5 2,0	1,5 1,5 1,3 2,0 2,0 1,4 1,5 1,5 2,0
	<b>Pompalar</b> U-Santrifüj H-Deplasman (Tek Silindirli) M-Deplasman (Çok Silindirli) M-Spiral pompa U-Döner (dişli veya paletli)	<b>Pumps</b> U-Centrifugal H-Displacement (single-cylinder) M-Displacement (multi-cylinder) M-Spiral Pumps U-Rotary (gear or vane type)	<b>Pumpen</b> U-Kreiselpumpen H-Verdrängerpumpen (1 Kolben) M-Verdrängerpumpen (Vielkolben) M-Spiral Pumpen U-Zahnrad-, Paletten-pumpen	1,2 1,4 1,2 1,3 1,3	1,4 1,5 1,4 1,3 1,3	1,4 1,6 1,4 1,4 1,4	1,5 1,8 1,5 1,5 1,3
Metal Sektörü Metal Working Industry Stahl- und Eisenindustrie	<b>Metal Hadde Makinaları</b> H-Çift yönlü ham demir haddesi H-Çift yönlü şahmerdan haddesi H-Çift yönlü sac haddesi H-Çift yönlü plaka haddesi H-Çift yönlü boru haddesi U-Hadde aralık ayarı H-Tel çekme makinaları U-Kütük itici U-Sac bükme M-Makaralı doğrultucu H-Sarma makaraları	<b>Metal Working Mills</b> H-Reversing blooming mills H-Reversing slabbing mills H-Reversing sheet mills H-Reversing plate mills H-Reversing tube mills U-Roll adjustment drives H-Wire drawing machines U-Ingot pushers U-Plate tilters M-Roller straighteners H-Winding machines	<b>Metallwalzen</b> H-Blechwalzen (Vor-, Rückwärts) H-Brammen (Vor-, Rückwärts) H-Feinblechwalz. (Vor-, Rückwärts) H-Grobblechwalz. (Vor-, Rückwärts) H-Rohrwalzen (Vor-, Rückwärts) U-Walzenanstellungen H-Drahtziehen U-Blockdrücker U-Blechbieger M-Rollenrichtmaschinen H-Haspeln	2,5 2,5 2,0 1,8 1,8 0,9 1,6 1,0 1,0 1,6 1,6	2,5 2,5 2,0 1,8 1,8 1,0 1,8 1,2 1,0 1,6 1,6	2,5 2,5 2,0 1,8 1,8 1,0 1,8 1,2 1,2 1,6 1,6	2,5 2,5 2,0 1,8 1,8 1,0 2,0 1,2 1,2 1,6 1,8
	<b>Makaslar</b> M-Sürekli kesim U-Eksantrik tip	<b>Shears</b> M-Continuous U-Crank type	<b>Scheren</b> M-Durchgehendes Schnitt U-Kurbelschnitt	1,5 1,2	1,5 1,2	1,5 1,2	1,5 1,2
	<b>Tekerli Yürütücü</b> M-Sürekli çalışan yürütücü H-Dur kalk çalışan yürütücü	<b>Roller tables</b> M-Continuous H-Intermittend	<b>Rollgänge</b> M-Durchlauf H-Stossartig	1,5 2,0	1,5 2,0	1,5 2,0	1,5 2,0
	<b>Enerji Sektörü</b> Energy Energie	H-Frekans dönüştürme H-Su çarkları (düşük hız) H-Su türbinleri	H-Frequency converters H-Water wheels (low speed) H-Water turbines	H-Frequenzumformer H-Wasserräder (langsam drehend) H-Wasserturbinen	1,8 1,7 2,0	1,8 1,8 2,2	1,8 1,8 2,4
<b>Kompresörler</b> Compressors Verdichter	H-Deplasman tipi (pistonlu) M-Santrifüj tipi H-Vidalı	H-Reciprocating M-Centrifugal compressors H-Screw-type	H-Kolbenverdichter M-Rotierende Verdichter H-Schraubenverdichter	1,8 1,4 1,5	1,8 1,4 1,5	1,8 1,5 1,6	1,9 1,5 1,8
<b>Krenler</b> Cranes Krananlagen	M-Kren döndürme U-Palangalı çekme H-Kren yürütme U-Kren yük kaldırma M-Vinç kolu kaldırma	M-Slewing gears U-Luffing gears H-Travelling gears U-Hoisting gears M-Derricking jib cranes	M-Drehwerke U-Einziehwerke H-Fahrwerke U-Hubwerke M-Wippwerke	1,2 1,0 1,6 1,0 1,2	1,6 1,2 1,8 1,2 1,4	1,8 1,4 1,8 1,4 1,4	2,0 1,4 2,0 1,4 1,6



# Genel Bilgiler

## General Information

### Einführung



Önerilen servis faktörleri Recommended service Factors Empfehlung für Betriebsfaktoren				Günlük Çalışma Saati Operation time per day Betriebsstunden pro Tag						
				h<4	4 - 8	8 - 16	h>16			
Gıda Sektörü Food Industry Lebensmittel- industrie	<b>Kamıştan Şeker Üretimi</b> H-Kamış bıçağı H-Kamış değirmeni	<b>Cane Sugar Production</b> H-Cane knives H-Cane mills	<b>Rohrzuckerherstellung</b> H-Zuckerrohr-Messer H-Zuckerrohr-Mühle	1,7 1,7	1,7 1,7	1,8 1,8	1,8 1,8			
	<b>Pancardan Şeker Üretimi</b> U-Pancar dilimleme M-Sıkma, soğutma, kaynatma H-Pancar yıkama H-Pancar kesme	<b>Beet Sugar Production</b> U-Beet cassettes macerators M-Extraction, coolers, boilers H-Sugar beet washing machine H-Sugar beet cutters	<b>Rübenzuckerherstellung</b> U-Schnitzelmaschine M-Extraction, Kühlen, Kochen H-Rübenwäsche H-Schneidmaschine	1,2 1,4 1,5 1,5	1,3 1,5 1,6 1,6	1,4 1,6 1,6 1,6	1,5 1,6 1,7 1,7			
	<b>Diğer Gıda</b> H-Ezme ve öğütme U-Dilimleme U-Kurutma tamburları	<b>Other Food</b> H-Crushers and mills U-Slicers U-Drying drums	<b>Andere Nahrungsmittel</b> H-Quetschen, mahlen U-Schnitzelmaiche U-Trockner-Trommel	1,8 1,2 1,2	1,8 1,3 1,3	1,8 1,4 1,4	1,8 1,5 1,5			
Fanlar Fans Ventilatoren	<b>Soğutma Kuleleri</b> H-Kuru soğutma kuleleri M-Yaş soğutma kuleleri	<b>Cooling towers</b> H-Dry cooling towers M-Wet cooling towers	<b>Kültürme</b> H-Trockenkühlturm M-Naßkühlturm	1,8 1,4	1,8 1,4	2,0 1,4	2,0 1,5			
	<b>Fanlar</b> M-Eksenel ve radyal fanlar U-Eşanjör fanları	<b>Fans</b> M-Axial and radial fans U-Heat exchangers	<b>Gebläse</b> M-Gebläse (axial und radial) U-Wärmetaucher	1,5 1,2	1,5 1,2	1,5 1,2	1,5 1,2			
Kağıt Sektörü Pulp and Paper Industry Papier-, Zellstoff- industrie	H-Kabuk sıyırma ve tamburu H-Haddeleme H-Kurutma silindiri H-Kalenderler H-Filtreler (vakum ve basınç) H-Dövücü ve talaş kırıcı H-Jordan değirmeni H-Presler M-Yıkayıcı filtreler	<b>H-Debarking drums and brakers</b> H-Rolls H-Dryer cylinders H-Calenders H-Filters (pressure and vacuum) H-Beaters and chippers H-Jordan mills H-Presses M-Washer filters	H-Entrindungsstrommeln H-Walzen H-Trockenzylinder H-Kalender H-Filter (Druck- und Saugfilter) H-Hackmaschinen und Häcksler H-Jordanmühlen H-Pressen M-Waschfilter	1,6 1,8 1,8 1,8 1,8 1,6 1,5 1,8 1,5	1,8 1,8 1,8 1,8 1,8 1,8 1,5 1,8 1,5	1,8 2,0 2,0 2,0 2,0 2,0 1,6 1,8 1,5	1,8 2,0 2,0 2,0 2,0 2,0 1,8 1,8 1,5			
	Çimento Sektörü Cement Industry Zementindustrie	H-Beton mixeri M-Kırıcı H-Döner fırın H-Boru değirmen M-Separatör H-Hadde değirmen	<b>H-Concrete mixers</b> M-Breakers H-Rotary kilns H-Tube mills M-Separators H-Roll crushers	H-Betonmischer M-Brecher H-Drehöfen H-Rohrmühle M-Sichter H-Walzenmühlen	1,5 1,4 2,0 2,0 1,6 2,0	1,5 1,5 2,0 2,0 1,6 2,0	1,5 1,6 2,0 2,0 1,6 2,0	1,5 1,7 2,0 2,0 1,6 2,0		
		Maden Sektörü Mining Industry Bergbau	H-Kırıcılar H-Titreşimli elek H-Kepçe kafa çevirme H-Kovalı elevatörler H-Katerpiller yürütme H-Kepçeli teker H-Kesici kafalar	<b>H-Crushers</b> H-Screen and shakers H-Slewing drives H-Bucket conveyors H-Caterpillar traveling gears H-Bucket wheel H-Cutter heads	H-Brecher H-Rüttler und Siebe H-Schwenkwerke H-Eimerketten H-Raupenfahrzeuge H-Schaufelradbagger H-Schneidköpfe	1,6 1,6 1,5 1,6 1,3 2,0 2,0	1,8 1,8 1,6 1,7 1,7 2,2 2,2	2,0 2,0 1,8 1,8 1,8 2,5 2,5	2,0 2,0 1,8 1,8 2,0 2,5 2,5	
			Konveyörler Conveyors Förderanlagen	H-Kovalı elevatörler H-Halatlı çekici H-Halatlı kaldırma U-Lastik bantlı konveyör U-Yük asansörleri H-İnsan asansörleri U-Levhali taşıyıcı U-Yürüyen merdiven M-Rayda yürüyen araçlar U-Helezon götürücü	<b>H-Bucket conveyors</b> H-Hauling winches H-Hoists U-Belt conveyors U-None-Human lifts H-Human lifts U-Apron conveyors U-Escalators M-Rail traveling gears U-Screw feeders	H-Becherwerke H-Förderhaspel H-Fördermaschinen U-Gurtbandförderer U-Lastaufzüge H-Personenaufzüge U-Plattenbänder U-Rolltreppen M-Schienenfahrzeuge U-Schneckenförderer	1,4 1,4 1,5 1,2 1,2 1,5 1,2 1,1 1,5 1,2	1,5 1,6 1,5 1,3 1,2 1,5 1,3 1,3 1,5 1,3	1,6 1,6 1,6 1,4 1,4 1,6 1,4 1,4 1,5 1,4	1,8 1,6 1,8 1,5 1,5 1,8 1,5 1,5 1,5 1,5



# Genel Bilgiler

## General Information

### Einführung



#### Radyal Yükler

Çıkış miline gelebilecek radyal yükler yatak ömrüne göre belirlenmiş ve tablolar halinde verilmiştir. Bu tablolarda verilen  $F_{qam}$  güvenilir radyal yükü  $f_s=1$  şartı ve yükün mil ortasını yüklediği durum için verilmiştir. Darbeli yüklerin olması durumunda daha önce verilmiş olan servis faktörü tablosundaki değerler dikkate alınmalıdır. Güvenilir aksiyal yük ( $F_{ama}$  veya  $F_{ame}$ ) verilen güvenilir radyal yükün ( $F_{qam}$  veya  $F_{qem}$ ) %25'i kadar alınır. Verilen radyal ve ekstenel yükler kuvvetin en kötü açı şartında etki ettiği durum için verilmiştir. Mil ortasına gelen kuvvetin açısına göre daha yüksek radyal yükler mümkündür (Firmamıza danışınız). Bağlantı şekline göre oluşan radyal yük  $F_q$  sayfa 19 de verilen formüller yardımı ile hesaplanır.

Redüktör seçiminde ;

$$\begin{matrix} F_{qa} \leq F_{qam} \\ F_{qe} \leq F_{qem} \end{matrix}$$

şartı göz önünde tutulmalı. Eğer etkiyen radyal kuvvet milin orta noktasında değil ise verilen güvenilir değer in aşağıda verilen formül ile düzeltilmesi gerekir.

$$F_{qam}' = F_{qam} \times \frac{t}{y + u}$$

$$F_{qem}' = F_{qem} \times \frac{t}{y + u}$$

"t", "y" Değerleri aşağıda verilmiştir. "u" Değeri görüldüğü gibi kuvvetin uygulama noktasıdır.

#### Overhung Loads

The permissible overhung loads are calculated by considering working life and is listed on the tables. The given permissible overhung loads  $F_{qam}$  are based on  $f_s=1$  and are valid for forces which are applied to the midpoint of the shaft. For shock loading applications the service factor given on the table must take into consideration. The permissible axial load ( $F_{ama}$  or  $F_{ame}$ ) is %25 x ( $F_{qam}$  or  $F_{qem}$ ). The listed permissible overhung loads are based on the worst loading direction. Higher overhung loads can be applied for different loading directions (Please ask if requested). The effective overhung load at the gear box shaft  $F_q$  will be determined with the given formulas on page 19.

In Selection ;

$$\begin{matrix} F_{qa} \leq F_{qam} \\ F_{qe} \leq F_{qem} \end{matrix}$$

these formulas must be taken into consideration. If the load is not applied at the midpoint of the shaft; the given permissible load must be corrected with the following formulas.

$$F_{qam}' = F_{qam} \times \frac{t}{y + u}$$

$$F_{qem}' = F_{qem} \times \frac{t}{y + u}$$

The values "t", "y" can be taken from the below table. The value "u" is the length of the application point as shown below.

#### Querkräfte

Die in den nachfolgenden Tabellen angegebenen zulässigen Radialbelastungen  $F_{qam}$  gelten bei Kraftangriff auf die Mitte Wellenendes. Den Angaben liegt der Betriebsfaktor  $f_s=1$  zu Grunde. Bei stoßartigen Belastungsfällen ist auch hier der entsprechende Betriebsfaktor zu berücksichtigen. Zulässige Axialkräfte  $F_{ama}$  oder  $F_{ame}$  können ohne weitere Nachrechnung bis zu einer Höhe von ca. 25% der zulässigen Radialbelastung  $F_{qam}$  oder  $F_{qem}$  aufgenommen werden. Bei der Ermittlung der zulässige Querkräfte sind höhere Werte möglich (Bitte Rückfragen). Die auftretende Querkraft  $F_q$  ab der Getriebewelle wird wie in der nachfolgenden Formel bestimmt.

Bei dieser Auswahl;

$$\begin{matrix} F_{qa} \leq F_{qam} \\ F_{qe} \leq F_{qem} \end{matrix}$$

müssen die oben agegebenen Bedingungen berücksichtigt werden. Ist der Kraftangriff nicht auf Wellenmitte, so kann die zulässige Querkraft mit Hilfe der unten stehenden Formel auf jede beliebige Stelle umgerechnet werden.

$$F_{qam}' = F_{qam} \times \frac{t}{y + u}$$

$$F_{qem}' = F_{qem} \times \frac{t}{y + u}$$

Die Werte "t" und "y" sind in den nachfolgenden Tabellen angegeben. Der Wert "u" ist die Stelle des Kraftangriffs wie auf der nächsten Seite angegeben.

Çıkış Milinde radyal kuvvet hesabı düzeltme katsayıları Overhung Load correcting values on output shaft Querkräfte auf Ausgangswelle Korrigierungszahlen			
Tip/Type/Typ	t	y	p
YRM1125	209	164	90
YRM1160	258	198	120
YRM1200	321	241	160
YRM2195	214	174	80
YRM2240	261	208	105
YRM2275	283	223	120
YRM2305	331	261	140
YRM2340	377	297	160
YRM2385	418	328	180
YRM2430	457	367	180
YRM2480	507	402	210
YRM2545	567	447	240
YRM3355	305	245	120
YRM3395-YRM4395	334	264	140
YRM3440-YRM4440	371	291	160
YRM3500-YRM4500	408	318	180
YRM3555-YRM4555	452	362	180
YRM3620-YRM4620	507	402	210
YRM3705-YRM4705	560	440	240

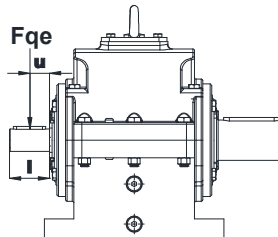
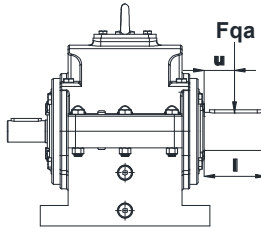

Giriş Milinde radyal kuvvet hesabı düzeltme katsayıları Overhung Load correcting values on input shaft Querkräfte auf Eingangswelle Korrigierungszahlen			
Tip/Type/Typ	t	y	p
YRM1125	200	160	80
YRM1160	240	190	100
YRM1200	296	236	120
YRM2195	192	167	50
YRM2240	238	203	70
YRM2275	255	220	70
YRM2305	301	261	80
YRM2340	327	287	80
YRM2385	360	315	90
YRM2430	395	340	110
YRM2480	458	398	120
YRM2545	468	408	130
YRM3355	251	226	50
YRM3395-YRM4395	274	244	60
YRM3440-YRM4440	316	286	60
YRM3500-YRM4500	348	308	80
YRM3555-YRM4555	391	341	100
YRM3620-YRM4620	426	376	100
YRM3705-YRM4705	475	425	100



# Genel Bilgiler

## General Information

### Einführung



#### Radyal Yüklerin Hesabı

Radyal Yük  $F_q(N)$ 'nin hesaplanmasında, gerekli tahrik momenti  $M (Nm)$ , kasnak veya dişli çapı  $D(mm)$  olmak üzere aşağıdaki formüller kullanılır.

1



#### 1. Elastik Kaplin

Çalışma sırasında oluşan sapmalar kaplinin güvenlik sınırları içinde ise kuvvetler ihmal edilebilir.

2



#### 2. Düz Dişli (20° kavrama açılı)

$$F_q = \frac{2100 \times M_2}{D}$$

3



#### 3. Küçük Hızlarda Zincir Dişli ( $z > 17$ )

$$F_q = \frac{2100 \times M_2}{D}$$

4



#### 4. Triger Kayış

$$F_q = \frac{2500 \times M_2}{D}$$

5



#### 5. V Kayış

$$F_q = \frac{5000 \times M_2}{D}$$

6



#### 6. Gerdirme Makaralı Kayış

$$F_q = \frac{5000 \times M_2}{D}$$

#### Calc. Of Overhung Loads

Radial Load  $F_q(N)$  is calculated with the following equations where required moment  $M (Nm)$  and hoop or gear diameter  $D (mm)$  is used.

#### 1. Elastic Coupling

If Elastic Coupling is working in its reliable working area, the overhung loads can be neglected.

#### 2. For Spur Gear (Pressure angle 20°)

$$F_q = \frac{2100 \times M_2}{D}$$

#### 3. For Chain Drive With Low Speed ( $z > 17$ )

$$F_q = \frac{2100 \times M_2}{D}$$

#### 4. For Triger Belt

$$F_q = \frac{2500 \times M_2}{D}$$

#### 5. For V Belt

$$F_q = \frac{5000 \times M_2}{D}$$

#### 6. Flat Belt With Spanning Pulley

$$F_q = \frac{5000 \times M_2}{D}$$

#### Berechnung der Querkräfte

Der Fall der radialen Belastung  $F_q(N)$  kann mit den angegebenen Gleichungen berechnet werden. Antriebsmoment  $M (Nm)$  und Zahnrad- oder Riemenscheiben Durchmesser  $D (mm)$ .

#### 1. Elastische Kupplung

Wenn die elastische Kupplung in ihren zulässige Arbeits toleranz arbeitet, können die radialen Belastungen vernachlässigt werden.

#### 2. Stirnradgetriebe (Angriffwinkel=20°)

$$F_q = \frac{2100 \times M_2}{D}$$

#### 3. Kettenantrieb mit niedriger Geschwindigkeit ( $z > 17$ )

$$F_q = \frac{2100 \times M_2}{D}$$

#### 4. Zahnriemenantrieb

$$F_q = \frac{2500 \times M_2}{D}$$

#### 5. Keilriemenantrieb

$$F_q = \frac{5000 \times M_2}{D}$$

#### 6. Flachriemenantrieb mit Spannungstrommel

$$F_q = \frac{5000 \times M_2}{D}$$





# Genel Bilgiler

## General Information

### Einführung



### Ekstruder Tiplerde Müsade Edilebilir Eksenel Yükler

Permissible Axial Loads for Extruder Types  
Zulässige Axialkräfte für Extruder Typ Getriebe

YRE2240				
n <sub>2</sub>	F <sub>ama</sub> [kN]			
	Ömür / Lifetime / Lebensdauer Lh [saat] / [hour] / [Stunde]			
	40000	20000	10000	5000
20	153.2	188.7	232.3	286.1
30	135.7	167.0	205.7	253.3
40	124.4	153.2	188.7	232.3
50	116.4	143.3	176.4	217.3
65	107.5	132.4	163.1	200.8
80	101.0	124.4	153.2	188.7
100	94.5	116.4	143.3	176.4
120	89.5	110.2	135.7	167.0
140	85.4	105.2	129.5	159.5
160	82.1	101.0	124.4	153.2
180	79.2	97.5	120.1	147.9
200	76.7	94.5	116.4	143.3
220	74.6	91.8	113.1	139.2
240	72.7	89.5	110.2	135.7
260	70.9	87.3	107.5	132.4
280	69.4	85.4	105.2	129.5
300	67.9	83.7	103.0	126.9
320	66.6	82.1	101.0	124.4

YRE2275				
n <sub>2</sub>	F <sub>ama</sub> [kN]			
	Ömür / Lifetime / Lebensdauer Lh [saat] / [hour] / [Stunde]			
	40000	20000	10000	5000
20	209.5	258.0	317.7	391.2
30	185.5	228.4	281.3	346.4
40	170.1	209.5	258.0	317.7
50	159.1	195.9	241.3	297.1
65	147.1	181.1	223.0	274.6
80	138.2	170.1	209.5	258.0
100	129.2	159.1	195.9	241.3
120	122.3	150.6	185.5	228.4
140	116.8	143.8	177.1	218.1
160	112.2	138.2	170.1	209.5
180	108.3	133.4	164.2	202.2
200	104.9	129.2	159.1	195.9
220	102.0	125.6	154.6	190.4
240	99.3	122.3	150.6	185.5
260	97.0	119.4	147.1	181.1
280	94.8	116.8	143.8	177.1
300	92.9	114.4	140.9	173.5
320	91.1	112.2	138.2	170.1

YRE2305				
n <sub>2</sub>	F <sub>ama</sub> [kN]			
	Ömür / Lifetime / Lebensdauer Lh [saat] / [hour] / [Stunde]			
	40000	20000	10000	5000
20	259.5	319.6	393.5	484.6
30	229.8	283.0	348.4	429.1
40	210.8	259.5	319.6	393.5
50	197.1	242.7	298.9	368.0
65	182.2	224.3	276.2	340.2
80	171.2	210.8	259.5	319.6
100	160.1	197.1	242.7	298.9
120	151.5	186.6	229.8	283.0
140	144.7	178.2	219.4	270.2
160	139.0	171.2	210.8	259.5
180	134.2	165.2	203.4	250.5
200	130.0	160.1	197.1	242.7
220	126.3	155.5	191.5	235.9
240	123.1	151.5	186.6	229.8
260	120.1	147.9	182.2	224.3
280	117.5	144.7	178.2	219.4
300	115.1	141.7	174.5	214.9
320	112.9	139.0	171.2	210.8

n<sub>2</sub> : Çıkış Devri [d/dak] / Output Speed [rpm] / Abtriebsdrehzahl [U/min]

YRE2340				
n <sub>2</sub>	F <sub>ama</sub> [kN]			
	Ömür / Lifetime / Lebensdauer Lh [saat] / [hour] / [Stunde]			
	40000	20000	10000	5000
20	165.7	204.1	251.3	309.5
30	146.7	180.7	222.5	274.0
40	134.6	165.7	204.1	251.3
50	125.9	155.0	190.9	235.0
65	116.3	143.2	176.4	217.2
80	109.3	134.6	165.7	204.1
100	102.2	125.9	155.0	190.9
120	96.8	119.2	146.7	180.7
140	92.4	113.8	140.1	172.5
160	88.8	109.3	134.6	165.7
180	85.7	105.5	129.9	160.0
200	83.0	102.2	125.9	155.0
220	80.7	99.3	122.3	150.6
240	78.6	96.8	119.2	146.7
260	76.7	94.5	116.3	143.2
280	75.0	92.4	113.8	140.1
300	73.5	90.5	111.4	137.2
320	72.1	88.8	109.3	134.6

YRE2385				
n <sub>2</sub>	F <sub>ama</sub> [kN]			
	Ömür / Lifetime / Lebensdauer Lh [saat] / [hour] / [Stunde]			
	40000	20000	10000	5000
20	200.1	246.4	303.5	373.7
30	177.2	218.2	268.7	330.8
40	162.5	200.1	246.4	303.5
50	152.0	187.2	230.5	283.8
65	140.5	173.0	213.0	262.3
80	132.0	162.5	200.1	246.4
100	123.4	152.0	187.2	230.5
120	116.8	143.9	177.2	218.2
140	111.6	137.4	169.2	208.3
160	107.2	132.0	162.5	200.1
180	103.5	127.4	156.9	193.2
200	100.2	123.4	152.0	187.2
220	97.4	119.9	147.7	181.9
240	94.9	116.8	143.9	177.2
260	92.6	114.1	140.5	173.0
280	90.6	111.6	137.4	169.2
300	88.7	109.3	134.6	165.7
320	87.0	107.2	132.0	162.5

YRE2430				
n <sub>2</sub>	F <sub>ama</sub> [kN]			
	Ömür / Lifetime / Lebensdauer Lh [saat] / [hour] / [Stunde]			
	40000	20000	10000	5000
20	250.2	308.0	379.3	467.1
30	221.5	272.7	335.8	413.6
40	203.1	250.2	308.0	379.3
50	190.0	233.9	288.1	354.7
65	175.6	216.2	266.3	327.9
80	165.0	203.1	250.2	308.0
100	154.3	190.0	233.9	288.1
120	146.1	179.9	221.5	272.7
140	139.5	171.7	211.5	260.4
160	134.0	165.0	203.1	250.2
180	129.3	159.2	196.1	241.5
200	125.3	154.3	190.0	233.9
220	121.8	149.9	184.6	227.3
240	118.6	146.1	179.9	221.5
260	115.8	142.6	175.6	216.2
280	113.2	139.5	171.7	211.5
300	110.9	136.6	168.2	207.1
320	108.8	134.0	165.0	203.1

n<sub>2</sub> : Çıkış Devri [d/dak] / Output Speed [rpm] / Abtriebsdrehzahl [U/min]



# Genel Bilgiler

## General Information

### Einführung



### Ekstruder Tiplerde Müsade Edilebilir Eksenel Yükler

Permissible Axial Loads for Extruder Types  
Zulässige Axialkräfte für Extruder Typ Getrieben

YRE2480				
n <sub>2</sub>	F <sub>ama</sub> [kN]			
	Ömür / Lifetime / Lebensdauer Lh [saat] / [hour] / [Stunde]			
	40000	20000	10000	5000
20	519.1	639.2	787.1	969.2
30	459.6	565.9	696.9	858.1
40	421.5	519.1	639.2	787.1
50	394.2	485.4	597.8	736.1
65	364.3	448.7	552.5	680.3
80	342.3	421.5	519.1	639.2
100	320.1	394.2	485.4	597.8
120	303.1	373.2	459.6	565.9
140	289.4	356.3	438.8	540.3
160	278.0	342.3	421.5	519.1
180	268.3	330.4	406.9	501.0
200	260.0	320.1	394.2	485.4
220	252.6	311.1	383.1	471.7
240	246.1	303.1	373.2	459.6
260	240.3	295.9	364.3	448.7
280	235.0	289.4	356.3	438.8
300	230.2	283.4	349.0	429.8
320	225.8	278.0	342.3	421.5

YRE2545				
n <sub>2</sub>	F <sub>ama</sub> [kN]			
	Ömür / Lifetime / Lebensdauer Lh [saat] / [hour] / [Stunde]			
	40000	20000	10000	5000
20	650.4	800.9	986.2	1214.5
30	575.8	709.1	873.2	1075.2
40	528.2	650.4	800.9	986.2
50	494.0	608.3	749.0	922.3
65	456.5	562.2	692.3	852.4
80	428.9	528.2	650.4	800.9
100	401.1	494.0	608.3	749.0
120	379.8	467.6	575.8	709.1
140	362.6	446.5	549.8	677.0
160	348.3	428.9	528.2	650.4
180	336.2	414.0	509.8	627.8
200	325.8	401.1	494.0	608.3
220	316.6	389.8	480.0	591.1
240	308.4	379.8	467.6	575.8
260	301.1	370.7	456.5	562.2
280	294.4	362.6	446.5	549.8
300	288.4	355.1	437.3	538.5
320	282.9	348.3	428.9	528.2

n<sub>2</sub> : Çıkış Devri [d/dak] / Output Speed [rpm] / Abtriebsdrehzahl [U/min]

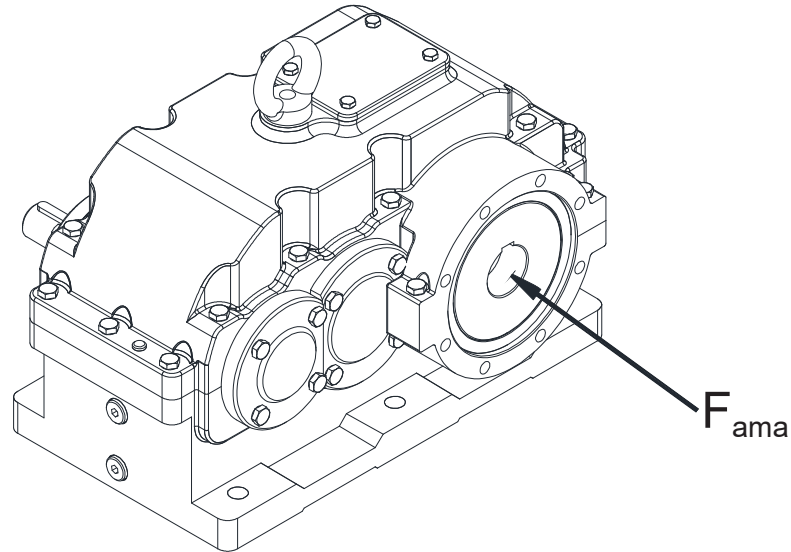



# Genel Bilgiler

## General Information

### Einführung



#### Eşdeğer Güç Hesabı

Sabit devirde, ancak değişken momentlerde (güçlerde) çalışan redüktörler için eşdeğer tork altındaki, eşdeğer güç hesaplanabilir. Bu eşdeğer güç kullanılarak bilinen sabit güçteki redüktör seçim yöntemi kullanılarak seçim yapılabilir. Burada ağırlıklı torka göre eşdeğer anma torku belirlenmektedir. Hesaplanan bu güçte çalışan redüktör, teorik olarak, değişken yüklerde çalışan redüktör ile aynı emniyet değerine ve ömre sahiptir.

Bir çevrim boyunca oluşan değişken torklar, en yüksek torktan, en düşüğe doğru yatay zaman eksenini boyunca sıralanır (bakınız alttaki şekil). Bu şekile göre eşdeğer tork şu formül ile hesaplanır;

$$T_e = \left( \frac{\Delta t_1 \times T_1^{6.6} + \dots + \Delta t_n \times T_n^{6.6}}{t} \right)^{\frac{1}{6.6}}$$

Eğer  $T_n$  değerleri (en düşük tork),  $T_e$ 'nin 0,5 katının altında ise, bu tork dilimi yok sayılarak, işlem tekrarlanır;

Eğer  $T_n < T_e \times 0.5$  ise

$$T_e = \left( \frac{\Delta t_1 \times T_1^{6.6} + \dots + \Delta t_{n-1} \times T_{n-1}^{6.6}}{t - \Delta t_n} \right)^{\frac{1}{6.6}}$$

Tüm  $T_n$  değerleri  $T_e$ 'nin 0,5 katının üzerinde ise, eşdeğer güç aşağıdaki gibi hesaplanır;

$$P_{eq} = P_N = \frac{T_e \times n}{9550}$$

Eşdeğer gücün bulunmasından sonra eşdeğer güç değeri kullanılarak, bu katalogta verilen redüktör seçimi bölümünde anlatılan adımlar uygulanarak redüktör seçimi tamamlanır.

#### Equivalent Power Rating Calculation

The equivalent power by an equivalent constant torque can be calculated for gearboxes working in constant speed but variable torques (or powers). Using this equivalent power it is possible to make a gearbox selection according to the usual gearbox selection method with constant torques. The equivalent torque will be determined according to the mean of dominating torques. The gearbox working in constant equivalent torque will theoretically have the same lifetime and safety compared to the variable torque one.

To calculate the equivalent torques, the variable torques in a cycle must be sorted from the maximal to the minimal on a horizontal time line (Check the graphic below). According to the graphic below the equivalent torque can be calculated with the following formula;

$$T_e = \left( \frac{\Delta t_1 \times T_1^{6.6} + \dots + \Delta t_n \times T_n^{6.6}}{t} \right)^{\frac{1}{6.6}}$$

If  $T_n$  (the lowest torque) is lower than 50 % of  $T_e$ , this torque part must be taken out of the torque graph and the calculation must be repeated;

If  $T_n < T_e \times 0.5$  then

$$T_e = \left( \frac{\Delta t_1 \times T_1^{6.6} + \dots + \Delta t_{n-1} \times T_{n-1}^{6.6}}{t - \Delta t_n} \right)^{\frac{1}{6.6}}$$

If all  $T_n$  values are higher than 50% of  $T_e$  then the equivalent power can be calculated by the following formula;

$$P_{eq} = P_N = \frac{T_e \times n}{9550}$$

After the equivalent power is determined the selection of gearbox is made according to the selection procedures given on the gearbox selection part in this catalogue.

#### Berechnung Äquivalenter Leistung

Die äquivalente Leistung bei äquivalentem Drehmoment kann für Getrieben mit konstanten Drehzahl und variablen Momenten berechnet werden. Mit dieser Leistung kann das Getriebe ausgelegt werden, wie bei der konstanten Leistung. Man bestimmt hiermit also die maßgebende Belastung. Das ausgelegte Getriebe erreicht theoretisch die gleiche Lebensdauer und hat die gleiche Sicherheit.

Für die Berechnung der äquivalenten Drehmoment müssen die einzelnen Drehmomentanteile auf eine Zeitachse von größten bis zu kleinsten angeordnet werden (siehe unteres Bild). Das äquivalente Drehmoment wird mit der folgenden Formel berechnet;

$$T_e = \left( \frac{\Delta t_1 \times T_1^{6.6} + \dots + \Delta t_n \times T_n^{6.6}}{t} \right)^{\frac{1}{6.6}}$$

Wenn  $T_n$  (niedrigstes Drehmoment) kleiner als 50% von  $T_e$  ist, muss dieser Anteil vernachlässigt werden und die Berechnung soll neu durchgeführt werden;

Wenn  $T_n < T_e \times 0.5$  dann

$$T_e = \left( \frac{\Delta t_1 \times T_1^{6.6} + \dots + \Delta t_{n-1} \times T_{n-1}^{6.6}}{t - \Delta t_n} \right)^{\frac{1}{6.6}}$$

Wenn alle  $T_n$  Werte höher als 50% von  $T_e$  sind, dann wird die äquivalente Leistung mit der folgenden Formel berechnet;

$$P_{eq} = P_N = \frac{T_e \times n}{9550}$$

Nach Bestimmung der äquivalenten Leistung, erfolgt die Getriebeauslegung wie bei konstanter Leistung. Die Auswahlverfahren für konstante Leistung ist in diesem Katalog angegeben.

(Moment / Torque / Moment)

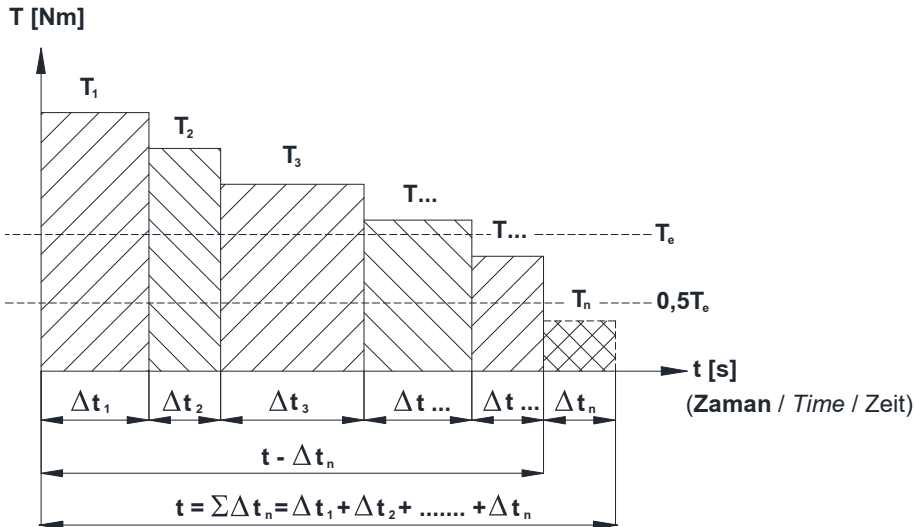



# Genel Bilgiler

## General Information

### Einführung



#### Eşdeğer Güç Hesabı Örneği

Çift yönlü çalışan ham demir haddesi için aşağıdaki çalışma koşulları belirlenmiş;

##### Veriler:

Toplam bir iş çevrimi: 2 dak.

1. Yük kademesi: 48 kNm, 30 sn

2. Yük Kademesi: 32 kNm, 22 sn

3. Yük Kademesi: 28 kNm, 15 sn

4. Yük Kademesi: 16 kNm, 10 sn

5. Yük Kademesi: 5 kNm, 43sn

Makina sabit devri: 50 d/dak

Redüktör seçimine esas olacak eşdeğer yük aranmaktadır.

##### Çözüm:

Bir çevrimin toplam zamanı;

$$t = t_1 + t_2 + t_3 + t_4 + t_5 = 120 \text{ sn}$$

Eşdeğer Tork;

$$T_e = \left( \frac{30 \times 48^{6,6} + \dots + 43 \times 5^{6,6}}{120} \right)^{\frac{1}{6,6}}$$
$$= 39,2 \text{ kNm}$$

%50 eşdeğer tork;

$$0,5 \times T_e = 19,6 \text{ kNm}$$

Her bir tork dilimi bu değer üzerinde olmalı

$$T_{4,5} < 0,5 \times T_e$$

%50 torkun altındakileri çıkararak hesabı tekrarlayalım;

$$t' = t_1 - t_4 - t_5 = 120 - 43 - 10 = 67 \text{ s}$$

$$T_e = \left( \frac{30 \times 48^{6,6} + 22 \times 32^{6,6} + 15 \times 28^{6,6}}{67} \right)^{\frac{1}{6,6}}$$
$$= 42,9 \text{ kNm}$$

Moment ve devir değerlerini kullanarak eşdeğer gücümüzü hesaplayalım;

$$P_{eq} = \frac{T_e \times n}{9550} = \frac{42,9 \times 1000 \times 50}{9550} = 225 \text{ kW}$$

Yukarıdaki güç ve devir değeri kullanılarak bu katalogta anlatılan seçim prosedürü ile redüktör seçimi yapılabilir.

#### Equivalent Power Rating Sample

The following data is given for a reversing blooming mill;

##### Torque steps:

Total one cycle time: 2 min.

1st torque part: 48 kNm, 30 s

2nd torque part: 32 kNm, 22 s

3th torque part: 28 kNm, 15 s

4th torque part: 16 kNm, 10 s

5th torque part: 5 kNm, 43 s

Machine constant speed: 50 rpm

The equivalent power, which is required for gear unit selection, is to determine.

##### Solution:

Total time in a cycle;

$$t = t_1 + t_2 + t_3 + t_4 + t_5 = 120 \text{ sn}$$

Equivalent Torque;

$$T_e = \left( \frac{30 \times 48^{6,6} + \dots + 43 \times 5^{6,6}}{120} \right)^{\frac{1}{6,6}}$$
$$= 39,2 \text{ kNm}$$

50% of Equivalent torque;

$$0,5 \times T_e = 19,6 \text{ kNm}$$

Every torque part must be lower than this value;

$$T_{4,5} < 0,5 \times T_e$$

We are repeating the calculation by taking out the torque parts, which are below 50%;

$$t' = t_1 - t_4 - t_5 = 120 - 43 - 10 = 67 \text{ s}$$

$$T_e = \left( \frac{30 \times 48^{6,6} + 22 \times 32^{6,6} + 15 \times 28^{6,6}}{67} \right)^{\frac{1}{6,6}}$$
$$= 42,9 \text{ kNm}$$

By using the equivalent torque and constant speed we calculate the equivalent power;

$$P_{eq} = \frac{T_e \times n}{9550} = \frac{42,9 \times 1000 \times 50}{9550} = 225 \text{ kW}$$

Now by using the above calculated equivalent power and constant speed we can make the gear-box selection with the procedures described in this catalogue.

#### Beispiel für Äquivalente Leistung

Die nachfolgenden Angaben sind für eine Blechreversierwalze;

##### Drehmoment stufen:

Gesamte Zeit für einem Arbeitszyklus: 2 min.

Drehmomentanteil 1: 48 kNm 30 s

Drehmomentanteil 2: 32 kNm 22 s

Drehmomentanteil 3: 28 kNm 15 s

Drehmomentanteil 4: 16 kNm 10 s

Drehmomentanteil 5: 5 kNm 43 s

Maschine hat konstante Drehzahl: 50 U/min

Gesucht ist die äquivalente Leistung, die für die Getriebeauslegung nötig ist.

##### Lösung:

Gesamte Zeit für einem Arbeitszyklus;

$$t = t_1 + t_2 + t_3 + t_4 + t_5 = 120 \text{ sn}$$

Äquivalentes Drehmoment;

$$T_e = \left( \frac{30 \times 48^{6,6} + \dots + 43 \times 5^{6,6}}{120} \right)^{\frac{1}{6,6}}$$
$$= 39,2 \text{ kNm}$$

50% von äquivalenten Drehmoment;

$$0,5 \times T_e = 19,6 \text{ kNm}$$

Drehmomentanteile müssen größer als dieser Wert sein;

$$T_{4,5} < 0,5 \times T_e$$

Wir wiederholen die Berechnung nochmals ohne die kleine Drehmomentanteile;

$$t' = t_1 - t_4 - t_5 = 120 - 43 - 10 = 67 \text{ s}$$

$$T_e = \left( \frac{30 \times 48^{6,6} + 22 \times 32^{6,6} + 15 \times 28^{6,6}}{67} \right)^{\frac{1}{6,6}}$$
$$= 42,9 \text{ kNm}$$

Mit Hilfe von äquivalenten Drehmoment und konstanter Drehzahl berechnet man die äquivalente Leistung;

$$P_{eq} = \frac{T_e \times n}{9550} = \frac{42,9 \times 1000 \times 50}{9550} = 225 \text{ kW}$$

Nach Bestimmung der äquivalenten Leistung und konstanter Drehzahl, erfolgt die Getriebeauslegung dann wie die Getriebeauswahl gemäß dem in diesem Katalog beschriebenen Verfahren für konstante Leistung.



# Genel Bilgiler

## General Information

### Einführung



#### Redüktör Seçimi

Redüktör seçimi yapılırken aşağıdaki sıra uygulanmalıdır. Parametreler ve katsayılar için takip eden sayfalara bakınız. Firmamızın seçim konusunda yardımcı olması isteniyor ise lütfen takip eden sayfalarda verilen redüktör seçim formunu doldurarak firmamızın satış bölümü ile irtibata geçiniz.

1. Gerekli tahvil oranını tespit ediniz ;

$$i = \frac{n_1}{n_2}$$

2. Redüktör nominal gücünü tespit ediniz ;

$$P_N \geq P_M \times f_s \times k_1$$

3. Maksimum kalkış / duruş veya pik momentinizi kontrol ediniz ;

$$P_N \geq \frac{M_A \times n_1}{9550} \times k_2$$

4. Termik gücü ve ortam sıcaklığını kontrol ediniz ;

$$P_M \leq P_n \times t_1 \times t_2 \times t_4 \times t_5 \times t_6$$

5. Radyal yükleri kontrol ediniz ;

$$F_a \times f_s \leq F_{pa}$$

$$F_c \times f_s \leq F_{pc}$$

Detaylar için radyal yükler bölümüne bakınız.

#### Redüktör Seçim Örneği

Bir tambur halat mekanizması ile 50 tonluk kütle 3 m/dak hızla kaldırılacaktır. 8 donam bir halat sistemi düşünülmektedir. Tambur çapı 600 mm dir. Tambur tek tarafından yataklanmıştır. Redüktör motor bağlantısı kaplinle yapılmıştır.

#### Veriler:

- Günde 8 saat, 30 çevrim/saat çalışacaktır.  
1. Makina gücü ihtiyacı 31 kW  
2. Makina kalkış momenti ihtiyacı 315 Nm  
3. Çıkış momenti ihtiyacı 23.311 Nm  
4. Kullanılan motor 37 kW, 1400 d/dak, AC  
5. Tambur devri 12,7 d/dak  
6. Çevre sıcaklığı 20°C, deniz seviyesinden yükseklik 1000 m, hava hızı 1,25 m/sn  
7. Redüktör montaj pozisyonu M1

#### Çözüm :

1. Gerekli tahvil oranının bulunması ;

$$i = \frac{n_1}{n_2} = \frac{1400}{12,7} = 110,23$$

2. Redüktör nominal gücünün bulunması ;

$$P_N \geq P_M \times f_s \times k_1$$

Motor gücü ihtiyacı  $P_M = 31 \text{ kW}$  verilmiştir. Servis faktörü,  $f_s = 1,5$  (sayfa 17). Tahrik makinası faktörü  $k_1 = 1$  (sayfa 16).

$$P_N \geq 31 \times 1,5 \times 1 = 46,5 \text{ kW}$$

YRM3705,  $i=102,56$ ,  $P_N=49 \text{ kW}$ ,  $P_{11}=73 \text{ kW}$ ,  $F_{qam}=115 \text{ kN}$  yatık tip redüktör seçilmiştir.

#### Gear Unit Selection

For the correct gearbox selection please use the following steps. For the unit designation and factors refer to the following pages. If you request selection support please fill in the gearbox selection form given on the following pages and contact our company.

1. Find the transmission ratio ;

$$i = \frac{n_1}{n_2}$$

2. Determine nominal power rating of the gear unit ;

$$P_N \geq P_M \times f_s \times k_1$$

3. Check the maximum starting / braking or peak torque ;

$$P_N \geq \frac{M_A \times n_1}{9550} \times k_2$$

4. Check thermal power and environment temperature.

$$P_M \leq P_n \times t_1 \times t_2 \times t_4 \times t_5 \times t_6$$

5. Check the radial loads ;

$$F_a \times f_s \leq F_{pa}$$

$$F_c \times f_s \leq F_{pc}$$

For more information please refer to radial loads section.

#### Gear Unit Selection Sample

A gearbox for hoisting unit with a 50 tons of load, 3 m/min lifting speed, 8 number of pulleys with a main pulley diameter of 600 mm supported from one side will be selected. The motor connecton will be done with a coupling.

#### Datas:

- Running 8 hours per day, 30 cycles per hour.  
1. Power consumption 31 kW  
2. Required starting torque 315 Nm  
3. Required output torque 23.311 Nm  
4. Used motor power 37 kW, 1400 rpm, AC  
5. Main pulley speed 12,7 rpm  
6. Ambient temperature 20°C, 1000 m above sea level, wind speed 1,25 m/s  
7. Mounting position M1

#### Solution :

1. Find the transmission ratio ;

$$i = \frac{n_1}{n_2} = \frac{1400}{12,7} = 110,23$$

2. Determine nominal power rating ;

$$P_N \geq P_M \times f_s \times k_1$$

Power consumption is  $P_M = 31 \text{ kW}$ , service factor  $f_s = 1,5$  (p. 17). Driving machine factor  $k_1 = 1$  (p. 16).

$$P_N \geq 31 \times 1,5 \times 1 = 46,5 \text{ kW}$$

YRM3705,  $i=102,56$ ,  $P_N=49 \text{ kW}$ ,  $P_{11}=73 \text{ kW}$ ,  $F_{qam}=115 \text{ kN}$  gearbox is selected.

#### Getriebe Auswahl

Für eine richtige Getriebeauslegung benutzen Sie bitte folgendes Verfahren. Für Bezeichnung ; Erklärungen und Faktoren gelten die folgenden Seiten. Wenn sie eine Frage betreffender Getriebeauslegung haben, bitten wir Sie das Auslegungsformular auf den folgenden Seiten auszufüllen und mit unserer Firma Kontakt aufzunehmen.

1. Bestimmung der Übersetzung ;

$$i = \frac{n_1}{n_2}$$

2. Bestimmung der Getriebe-Nennleistung ;

$$P_N \geq P_M \times f_s \times k_1$$

3. Kontrolle auf Maximalmoment bei Betriebspitzen-, Anfahr- und Bremsmoment ;

$$P_N \geq \frac{M_A \times n_1}{9550} \times k_2$$

4. Kontrolle auf Wärme-Grenzleistung ;

$$P_M \leq P_n \times t_1 \times t_2 \times t_4 \times t_5 \times t_6$$

5. Prüfung der Zulässigkeit von Zusatzkräften auf die Abtriebs- und / oder Antriebswelle ;

$$F_a \times f_s \leq F_{pa}$$

$$F_c \times f_s \leq F_{pc}$$

Siehe Seiten " Querkräfte " für mehr Information.

#### Getriebe Auslegung Beispiel

Eine Getriebe für einen Hubwerk mit 50 tonen Last, 3 m/min Hubgeschwindigkeit, 8 fache Umschlingung mit Trommeldurchmesser 600 mm, einseitig gelagert, wird ausgelegt. Der Elektrische Motor ist mit einer Kupplung verbunden.

#### Daten:

- Laufzeit 8 Stunden/Tag, 30 Zyklen/Stunde.  
1. Leistungsbedarf, 31 kW  
2. Anfahrmoment (Motor), 315 Nm  
3. Abtriebsdrehmoment Bedarf, 23.311 Nm  
4. Motor Leistung 37 kW, 1400 upm, AC  
5. Wickeltrommel Drehzahl 12,7 d/dak  
6. Umgebungstemperatur 20°C, 1000 m über Seespiegel, Windgeschwindigkeit, 1,25 m/s  
7. Bauform, M1

#### Lösung :

1. Bestimmung der Übersetzung ;

$$i = \frac{n_1}{n_2} = \frac{1400}{12,7} = 110,23$$

2. Bestimmung der Getriebe-Nennleistung ;

$$P_N \geq P_M \times f_s \times k_1$$

Leistungsbedarf ist  $P_M = 31 \text{ kW}$ , Betriebsfaktor  $f_s = 1,5$  (Seite 17). Antriebsmaschinefaktor  $k_1 = 1$  (Seite 16).

$$P_N \geq 31 \times 1,5 \times 1 = 46,5 \text{ kW}$$

YRM3705,  $i=102,56$ ,  $P_N=49 \text{ kW}$ ,  $P_{11}=73 \text{ kW}$ ,  $F_{qam}=115 \text{ kN}$  Getriebe ausgewählt.





# Genel Bilgiler

## General Information

### Einführung



### 3. Maksimum kalkış (pik) momentinin kontrolü ;

$$P_N \geq \frac{M_A \times n_1}{9550} \times k_2 = \frac{241 \times 1400}{9550} \times 0,65 = 22,9 \text{ kW}$$

$$47 \text{ kW} \geq 22,9 \text{ kW}$$

olduğundan uygundur.

### 4. Termik gücün kontrolü ;

$$P_M \leq P_n \times t_1 \times t_2 \times t_4 \times t_5 \times t_6$$

Termik güç;  $P_{ti}=72 \text{ kW}$  , soğuma faktörü;  $t_1=1,35$  (sayfa 15), yükseklik faktörü;  $t_2=1$  (sayfa 15), yağlama faktörü;  $t_4=1$  (sayfa 15), hava hızı faktörü;  $t_5=1$  çevre sıcaklığı faktörü  $t_6=1$  (sayfa 15).

$$P_M \leq 72 \times 1,35 \times 1 \times 1 \times 1 \times 1 = 97,2 \text{ kW}$$

$$P_M = 31 \text{ kW} \leq P_i = 97,2 \text{ kW}$$

olduğundan ek bir soğutma gerekmemektedir.

### 5. Çıkış radyal yük kontrolü ;

Redüktör motor bağlantısı kaplin ile yapıldığından girişte radyal kuvvet yoktur. Tambur tek taraflı yataklığından, radyal yükün yarısı redüktörde çıkış miline düşmektedir.

$$F_a = \frac{2100 \times M_2}{D \times 2} = \frac{2100 \times 23331}{600 \times 2} = 41 \text{ kN}$$

$$41 \text{ kN} \leq 115 \text{ kN} \text{ olduğundan uygundur.}$$

### 3. Checking the maximum starting torque;

$$P_N \geq \frac{M_A \times n_1}{9550} \times k_2 = \frac{241 \times 1400}{9550} \times 0,65 = 22,9 \text{ kW}$$

$$47 \text{ kW} \geq 22,9 \text{ kW}$$

condition is fulfilled.

### 4. Checking the thermal power ;

$$P_M \leq P_n \times t_1 \times t_2 \times t_4 \times t_5 \times t_6$$

Thermal power;  $P_{ti}=60 \text{ kW}$  , cooling factor;  $t_1=1,35$  (p. 15), altitude factor;  $t_2=1$  (p. 15), lubrication factor;  $t_4=1$  (p. 15), wind velocity factor;  $t_5=1$  (p. 15), Environment Temperature Factor  $t_6=1$ .

$$P_M \leq 72 \times 1,35 \times 1 \times 1 \times 1 \times 1 = 97,2 \text{ kW}$$

$$P_M = 31 \text{ kW} \leq P_i = 97,2 \text{ kW}$$

condition is fulfilled, needs no extra cooling.

### 5. Check the radial loads ;

There is no radial load on input shaft because of coupling connection. Because the main pulley is supported from one side, half of the radial load is on the gear unit's output shaft.

$$F_a = \frac{2100 \times M_2}{D \times 2} = \frac{2100 \times 23331}{600 \times 2} = 41 \text{ kN}$$

$$41 \text{ kN} \leq 115 \text{ kN} \text{ condition is fulfilled.}$$

### 3. Kontrolle auf Anfahrmoment (oder Spitzen) ;

$$P_N \geq \frac{M_A \times n_1}{9550} \times k_2 = \frac{241 \times 1400}{9550} \times 0,65 = 22,9 \text{ kW}$$

$$47 \text{ kW} \geq 22,9 \text{ kW}$$

Getriebe ist ausreichend.

### 4. Kontrolle auf Wärmegrenzleistung ;

$$P_M \leq P_n \times t_1 \times t_2 \times t_4 \times t_5 \times t_6$$

Thermischeleistung;  $P_{ti}=60 \text{ kW}$  , Kühlungsfaktor;  $t_1=1,35$  (Seite 30), Höhenfaktor;  $t_2=1$  (Seite 15), Schmierungs-faktor;  $t_4=1$  (Seite 15), Windgeschwindigkeits-faktor;  $t_5=1$  (Seite 15).

$$P_M \leq 72 \times 1,35 \times 1 \times 1 \times 1 \times 1 = 97,2 \text{ kW}$$

$$P_M = 31 \text{ kW} \leq P_i = 97,2 \text{ kW}$$

Kühlung ist ausreichend; extra Kühlung ist nicht nötig

### 5. Prüfung der Querkräfte ;

Keine Querkraft auf der Antriebswelle wegen Verbindung mittels Kupplung. Da die Wickeltrommel nur auf einer Seite gelagert ist, wirkt nur die halbe Querkraft auf die Abtriebswelle.

$$F_a = \frac{2100 \times M_2}{D \times 2} = \frac{2100 \times 23331}{600 \times 2} = 41 \text{ kN}$$

$$41 \text{ kN} \leq 115 \text{ kN} \text{ Getriebe ist ausreichend.}$$



# Genel Bilgiler

## General Information

### Einführung



#### Redüktör Seçim Formu

Kullanıldığı Sektör.....  
Kullanıldığı Yer.....  
Gerekli Ortalama Devir.....d/dak

#### Makina ihtiyaç gücü:

-Normal..... kW  
-En çok..... kW  
-En az..... kW

#### Tahrik Şekli:

AC Motor [ ]  
AC Motor + Invertör [ ]  
DC Motor [ ]  
Hidromotor [ ]  
1-3 silindirli içten yanmalı [ ]  
2-4 silindirli içten yanmalı [ ]

#### Motor Gücü:

-Nominal..... kW

#### Motor Devri:

-Normal..... d/dak  
-En çok..... d/dak  
-En az..... d/dak

#### Motor Torku:

-Normal..... Nm  
-En çok..... Nm  
-En az..... Nm

#### Dönüş şekli:

saat yönü [ ] saat yönüne ters [ ] değişken [ ]

#### Günlük çalışma süresi:

<4 [ ] 4-8 [ ] 8-16 [ ] >16 [ ]

#### Saatteki start sayısı:

0-50 [ ] 50-100 [ ] 100-200 [ ]  
200-300 [ ] 300-500 [ ] 500-700 [ ]  
700-1000 [ ] >1000 [ ]

Motor Redüktör Arası Tahvil Oranı.....

Kalkış için gerekli moment.....Nm

#### Saatteki pik moment adedi:

1-5 [ ] 6-30 [ ] 31-100 [ ] >100 [ ]

#### Bir çevrimde aktif çalışma oranı (ED):

%100 [ ] %80 [ ] %60 [ ] 40% [ ] %20 [ ]

#### Deniz seviyesinden yükseklik:

<1000 [ ] <2000 [ ] <3000 [ ]  
<4000 [ ] <5000 [ ]

#### Montaj yeri:

Küçük kapalı oda ( $w < 1m/sn$ ) [ ]  
Kapalı oda ( $w < 3m/sn$ ) [ ]  
Büyük oda ve holler ( $w > 3m/sn$ ) [ ]  
Tamamen açık ortam [ ]

#### Çevre Şartları:

Normal [ ] Tozlu [ ] Nemli [ ]  
Korozif [ ] Kuru [ ]

#### Çevre Sıcaklığı:

Ortalama..... °C  
En Yüksek..... °C  
En Düşük..... °C

#### Kilit İhtiyacı:

Var [ ] Yok [ ]

#### Redüktör Giriş Opsiyonu:

T. [ ]

#### Redüktör Çıkış Opsiyonu:

00 [ ] 01 [ ] 0S [ ]

#### Montaj Pozisyonu:

M1 [ ] M2 [ ] M3 [ ] M4 [ ] M5 [ ] M6 [ ]

#### Giriş mili bağlantı şekli:

Elastik kaplin [ ]  
Fıçı tipi kaplin [ ]  
Rijit kaplin [ ]  
Hidrolik Kaplin [ ]  
Kayış kasnak [ ]  
Zincir dişli [ ]  
Pinyon dişli [ ]  
Bağlantı elemanı çapı.....mm  
Radyal yükü.....N  
Radyal yük "u" mesafesi.....mm  
Aksiyal yükü (mile doğru +).....N

#### Çıkış mili bağlantı şekli:

Elastik kaplin [ ]  
Fıçı tipi kaplin [ ]  
Rijit kaplin [ ]  
Kayış kasnak [ ]  
Zincir dişli [ ]  
Pinyon dişli [ ]  
Delik milli tork kolu [ ]  
Sıkma bilezikli tork kolu [ ]  
Bağlantı elemanı çapı.....mm  
Radyal yükü.....N  
Radyal yük "u" mesafesi.....mm  
Aksiyal yükü (mile doğru +).....N

#### Redüktör bağlantı yeri:

Gövde [ ] Flanş [ ] Tork kolu [ ]

#### Çıkış Mili Özelliği:

Dolu Mil Kamalı [ ]  
Dolu Mil Kamasız [ ]  
Delik Milli Sıkma Bilezikli [ ]  
Delik Milli [ ]  
Özel Mil [ ]

#### Giriş Mili Özelliği:

Kamalı [ ]  
Kamasız düz mil [ ]  
Özel Mil [ ]

**Tork kolu** [ ] Var [ ] Yok

#### Elektrik Gerilimi:

AC-Monofaze [ ] AC-Trifaze [ ] DC [ ]  
Voltaj.....Volt  
Frekans.....Hz

#### Koruma Sınıfı:

IP55 [ ] IP65 [ ] Exproof [ ]  
Diğer IP.....

#### Ekler:

Yük diyagramı [ ]  
Proje [ ]  
İstenen ana boyutlar [ ]  
Teknik veriler [ ]

#### Diğer Notlar:



# Genel Bilgiler

## General Information

### Einführung



#### Gearbox Selection Form

Field of Industry.....  
Application.....  
Required Average Speed..... rpm

#### Required Power on Driven Machine:

-Normal..... kW  
-Maximum..... kW  
-Minimum..... kW

#### Driving Machine:

AC Motor [ ]  
AC Motor + Inverter [ ]  
DC Motor [ ]  
Hydraulic Motor [ ]  
Piston Engine with 1-3 cylinder [ ]  
Piston Engine with 4-24 cylinder [ ]

#### Motor Power:

-Nominal.....kW

#### Motor Speed:

-Normal.....rpm  
-Maximum.....rpm  
-Minimum.....rpm

#### Motor Torque:

-Normal.....Nm  
-Maximum.....Nm  
-Minimum.....Nm

#### Direction of Rotation:

cw [ ] ccw [ ] variable [ ]

#### Working hours per day:

<4 [ ] 4-8 [ ] 8-16 [ ] >16 [ ]

#### Startings per cycle:

0-50 [ ] 50-100 [ ] 100-200 [ ]  
200-300 [ ] 300-500 [ ] 500-700 [ ]  
700-1000 [ ] >1000 [ ]

Transmission ratio between motor and gear unit.....

Required Starting Torque.....Nm

#### Peak torques per hour:

1-5 [ ] 6-30 [ ] 31-100 [ ] >100 [ ]

#### Effective working time in a cycle (ED):

%100 [ ] %80 [ ] %60 [ ] 40% [ ]  
20% [ ]

#### Altitude:

<1000 [ ] <2000 [ ] <3000 [ ]  
<4000 [ ] <5000 [ ]

#### Mounting Place:

Small closed room (w<1m/sn) [ ]  
Closed room (w<3m/sn) [ ]  
Big rooms and halls (w>=3m/sn) [ ]  
Outdoor [ ]

#### Ambient Conditions:

Normal [ ] Dusty [ ] Humid [ ]  
Corrosive [ ] Dry [ ]

#### Ambient Temperature:

Average.....°C  
Maximum.....°C  
Minimum.....°C

#### Backstop Required:

Yes [ ] No [ ]

#### Gearbox input options:

T.[ ]

#### Gearbox output options:

00 [ ] 01 [ ] 0S [ ]

#### Mounting Position:

M1 [ ] M2 [ ] M3 [ ] M4 [ ] M5 [ ] M6 [ ]

#### Input Shaft Connection Type:

Elastic Coupling [ ]  
Barrel Type Coupling [ ]  
Hydraulic Coupling [ ]  
Rigid Flange Coupling [ ]  
Pulley [ ]  
Chain Sprocket [ ]  
Pinion [ ]  
Diameter of Connection element.....mm  
Radial Load.....N  
"u" Distance of Radial Load.....mm  
Axial Load (Towards Shaft +) .....N

#### Output Shaft Connection Type:

Elastic Coupling [ ]  
Barrel Type Coupling [ ]  
Rigid Flange Coupling [ ]  
Pulley [ ]  
Chain Sprocket [ ]  
Pinion [ ]  
Hollow Shaft with Torque Arm [ ]  
Shrinc disc with Torque Arm [ ]  
Diameter of Connection Element.....mm  
Radial Load.....N  
"u" Distance of Radial Load.....mm  
Axial Load (Towards Shaft) .....N

#### Gearbox assembled by:

Housing [ ] Flange [ ] Torque Arm [ ]

#### Output Shaft Specification:

Solid Shaft with Keyway [ ]  
Solid Shaft without Keyway [ ]  
Hollow Shaft with Shrink Disc [ ]  
Hollow Shaft [ ]  
Special Shaft [ ]

#### Input Shaft Specification:

Solid Shaft with Keyway [ ]  
Solid Shaft without Keyway [ ]  
Special Shaft [ ]

**Torque arm** required Yes [ ] No [ ]

#### Electrical Supply:

AC-1 Phase [ ] AC-3 Phase [ ] DC [ ]  
Voltage.....Volt  
Frequency..... Hz

#### Protection Class:

IP55 [ ] IP65 [ ] Exproof [ ]  
Other IP.....

#### Attachments:

Load Diagram [ ]  
Project [ ]  
Required Dimensions [ ]  
Technical Specifications [ ]

#### Notes:



# Genel Bilgiler

## General Information

### Einführung



#### Formular für Getriebeauswahl

Industriebereich.....  
 Anwendung.....  
 Erforderliche Drehzahl.....U/min

#### Erforderliche Leistung für die Maschine:

-Normal.....kW  
 -Minimal.....kW  
 -Maximal.....kW

#### Antriebsmaschine:

AC Motor [ ]  
 AC Motor mit Frequenzumrichter [ ]  
 DC Motor [ ]  
 Hydromotor [ ]  
 Kolbenmaschinen mit 1-3 Zylinder [ ]  
 Kolbenmaschinen mit 2-4 Zylinder [ ]

#### Motorleistung:

-Nominal.....kW

#### Motordrehzahl:

-Normal.....U/min  
 -Maximal .....U/min  
 -Minimal.....U/min

#### Motordrehmoment:

-Normal.....Nm  
 -Maximal.....Nm  
 -Minimal.....Nm

#### Drehrichtung:

in Uhrzeigersinn [ ] gegen Uhrzeigersinn [ ]  
 veränderlich [ ]

#### Betriebsdauer in Stunden pro Tag:

<4 [ ] 4-8 [ ] 8-16 [ ] >16 [ ]

#### Anzahl der Anläufe pro Stunde:

0-50 [ ] 50-100 [ ] 100-200 [ ]  
 200-300 [ ] 300-500 [ ] 500-700 [ ]  
 700-1000 [ ] >1000 [ ]

Übersetzung zwischen Motor und Antriebs-  
 welle.....

Erforderliches Anlaufmoment.....Nm

#### Häufigkeit von Lastspitzen pro Stunde:

1-5 [ ] 6-30 [ ] 31-100 [ ] >100 [ ]

#### Einschaltdauer je Stunde (ED):

%100 [ ] %80 [ ] %60 [ ] 40% [ ] %20 [ ]

#### Höhenlage über Meeresspiegel (m):

<1000 [ ] <2000 [ ] <3000 [ ]  
 <4000 [ ] <5000 [ ]

#### Betriebsort:

Kleine geschlossene Räume (w<1m/sn) [ ]  
 Geschlossene Räume (w<3m/sn) [ ]  
 Große Räume und Hallen (w>=3m/sn) [ ]  
 im Freien [ ]

#### Umgebungsbedingungen:

Normal [ ] Staubig [ ] Feucht [ ]  
 Korrodierend [ ] Trocken [ ] Verklebend [ ]

#### Umgebungstemperatur:

Mittelwert ..... °C  
 Maximal.....°C  
 Minimal.....°C

#### Rücklaufsperre erforderlich:

Ja [ ] Nein [ ]

#### Getriebeeingangsvarianten:

T.. [ ]

#### Getriebeausgangsvarianten:

00 [ ] 01 [ ] 0S [ ]

#### Montageposition:

M1 [ ] M2 [ ] M3 [ ] M4 [ ] M5 [ ] M6 [ ]

#### Antriebswellenanschluss:

Elastische Kupplung [ ]  
 Trommelkupplung [ ]  
 Hydrokupplung [ ]  
 Starre Flanschkupplung [ ]  
 Keilriementrieb [ ]  
 Kettenrad [ ]  
 Ritzel [ ]  
 Durchmesser von Anschlusselement.....mm  
 Querkraft.....N  
 "u" Abstand von der Wellenschulter.....mm  
 Axialkraft (in Richtung der Welle +) .....N

#### Abtriebswellenanschluss:

Elastische Kupplung [ ]  
 Trommelkupplung [ ]  
 Starre Flanschkupplung [ ]  
 Keilriementrieb [ ]  
 Kettenrad [ ]  
 Ritzel [ ]  
 Hohlwelle mit Drehmomentstütze [ ]  
 Schrumpfscheibe mit Drehmomentstütze [ ]  
 Durchmesser von Anschlusselement.....mm  
 Querkraft.....N  
 "u" Abstand von der Wellenschulter.....mm  
 Axialkraft (in Richtung der Welle +) .....N

#### Montage zur Getriebegehäuse mit:

Gehäuse [ ] Flansch [ ] Drehmomentstütze [ ]

#### Eigenschaften der Abtriebswelle:

Vollwelle mit Passfeder [ ]  
 Vollwelle ohne Passfeder [ ]  
 Sonderwelle [ ]  
 Hohlwelle mit Schrumpfscheibe [ ]  
 Hohlwelle [ ]

#### Eigenschaften der Antriebswelle:

Vollwelle mit Paßfeder [ ]  
 Vollwelle ohne Paßfeder [ ]  
 Sonderwelle [ ]

#### Drehmomentstütze erforderlich Ja [ ] Nein [ ]

#### Spannungsversorgung:

AC-1 phasig [ ] AC-3 phasig [ ] DC [ ]  
 Spannung.....Volt  
 Frequenz.....Hz

#### Schutzart:

IP55 [ ] IP65 [ ] Exproof [ ]  
 Andere IP.....

#### Anhang:

Lastdiagramm [ ]  
 Projekt [ ]  
 Erforderliche Abmessungen [ ]  
 Technische Spezifikationen [ ]

#### Andere Merkmale:



# Genel Bilgiler

## General Information

### Einführung



#### Sembollerin Açıklaması

$i$  ..... : Tahvil oranı

$n_1$  .....[d/d]: Redüktör giriş mili devri

$n_2$  .....[d/d]: Redüktör çıkış mili devri

$P_N$  .....[kW]: Müsade edilen nominal giriş gücü ( bak. Güç Devir Tabloları)

$P_M$  .....[kW]: Tahrik edilecek makina için gerekli güç (Değişken yükler için eşdeğer nominal güç alınır)

$P_{t1}$  .....[kW]: Yardımcı soğutmasız redüktörlerde izin verilen termik kapasite

$f_s$  ..... : Gerekli servis faktörü ( syf.16)

$k_1$  ..... : Tahrik makinası faktörü ( syf.15)

$k_2$  ..... : Pik tork faktörü (syf. 14)

$t_1$  ..... : Soğuma faktörü (syf.14)

$t_2$  ..... : Hava soğutmalı redüktörlerde yükseklik faktörü (syf.15)

$t_3$  ..... : Serpantin veya eşanjör soğutmalı redüktörlerde, yükseklik faktörü (syf.33)

$t_4$  ..... : Yağlama faktörü (syf. 33)

$t_5$  ..... : Hava hızı faktörü ( syf.33)

$M_A$  ...[Nm]: Kalkış, duruş veya çalışma esnasında oluşabilecek anlık en yüksek tork değeri

$F_{qe}$  .... [kN]: Giriş miline gelen radyal yöndeki yükler

$F_{qa}$ .....[kN]: Çıkış miline gelen radyal yöndeki yükler

$F_{qem}$  .....[kN]: Giriş milinde izin verilen radyal yöndeki yükler (bak. Güç Devir tabloları)

$F_{qam}$ .....[kN]: Çıkış milinde izin verilen radyal yöndeki yükler (bak. Güç Devir tabloları)

$F_{ame}$ .....[kN]: Giriş milinde müsade edilen eksenel yükler

$F_{ama}$ .....[kN]: Çıkış milinde müsade edilen eksenel yükler

$F_q$  .....[N]: Çıkış milindeki radyal yükler

$F_a$  .....[N]: Çıkış milindeki eksenel yükler

#### Key of Symbols

$i$  ..... : Ratio

$n_1$  ..... [rpm]: Input speed of gearbox

$n_2$ .....[rpm]: Outspeed of gearbox

$P_N$ .....[kW]: Permissible nominal input power (given on performance tables)

$P_M$ .....[kW]: Power consumption of the driven machine (for alternating power, refer to equivalent power rating)

$P_{t1}$ .....[kW]: Thermal capacity for gear units without auxiliary cooling

$f_s$  ..... : Required service factor (p.32)

$k_1$  ..... : Driving machine factor (p.32)

$k_2$ ..... : Peak torque factor (p.32)

$t_1$  ..... : Cooling factor (p.32)

$t_2$  ..... : Altitude factor for gear units with air cooling (p.33)

$t_3$  ..... : Altitude factor for gear units with cooling coil or heat exchanger (p.33)

$t_4$  ..... : Lubrication factor (p.33)

$t_5$  ..... : Wind velocity factor (p.33)

$M_A$ .....[Nm]: Maximum peak torque, which could arise during starting, running or breaking

$F_{qe}$ .....[kN]: Radial loads applied to the input shafts

$F_{qa}$ .....[kN]: Radial loads applied to the output shafts

$F_{qem}$  .....[kN]: Permissible radial loads on the input shafts (refer to the perf. tables)

$F_{qam}$ .....[kN]: Permissible radial loads on the output shafts (refer to the perf. tables)

$F_{ame}$ .....[kN]: Permissible axial loads which can be applied to input shafts

$F_{ama}$ .....[kN]: Permissible axial loads which can be applied to output shafts

$F_q$  .....[N]: Overhung loads on output shaft

$F_a$  .....[N]: Axial loads on output shaft

#### Erklärung der Bezeichnungen

$i$  ..... : Übersetzung

$n_1$ .....[upm]: Antriebsdrehzahl

$n_2$ .....[upm]: Abtriebsdrehzahl

$P_N$  .....[kW]: Getriebe Nennleistung (Siehe Tabellen Drehzahl und Leistung)

$P_M$ .....[kW]: Leistung an der Abtriebswelle (Zur Berechnung variabler Leistungen die äquivalente Leistung benutzen)

$P_{t1}$  .....[kW]: Wärmegrenzleistung ohne Zusatzkühlung

$f_s$  ..... : Erforderlicher Betriebsfaktor (S. 32)

$k_1$  ..... : Antriebsmaschinen-Faktor (S. 32)

$k_2$  ..... : Spitzenmoment-Faktor (S. 32)

$t_1$  ..... : Kühlungs-Faktor (S. 32)

$t_2$  ..... : Höhen-Faktor ohne Zusatzkühlung oder mit Lüfterkühlung (S. 33)

$t_3$  ..... : Höhen-Faktor mit Kühlung durch Kühlschlange oder Wärmetaucher (S. 33)

$t_4$  ..... : Schmierungs-Faktor (S. 33)

$t_5$  ..... : Windgeschwindigkeits-Faktor (S. 33)

$M_A$  ...[Nm]: Max. Spitzenmoment ist der größte Moment der während Bremsen, Starten oder Betrieb entstehen kann

$F_{qe}$  .....[kN]: Querkräfte auf Antriebswelle

$F_{qa}$  .....[kN]: Querkräfte auf Abtriebswelle

$F_{qem}$  .....[kN]: Erlaubte Querkräfte auf Antriebswelle (Leistung und Drehzahl Übersicht Tabellen)

$F_{qam}$  ..... [kN]: Erlaubte Querkräfte auf Abtriebswelle (Leistung und Drehzahl Übersicht Tabellen)

$F_{ame}$ .....[kN]: Zulässige Axialkräfte auf Antriebswelle

$F_{ama}$ .....[kN]: Zulässige Axialkräfte auf Abtriebswelle

$F_q$  ..... [N]: Querkräfte auf Abtriebswelle

$F_a$ .....[N]: Axialkräfte auf Abtriebswelle





# Genel Bilgiler

## General Information

### Einführung



#### Yağlama

Redüktörlerin uzun ömürlü olması ve iyi performansla çalışabilmesi için, kullanılan yağın seçimi doğru olmalı ve belirtilen zamanlarda değişimleri yapılmalıdır.

Yağın seçiminde devir, çevre sıcaklığı, redüktör yağ sıcaklığı, çalışma koşulları ve yağ ömrü önem taşımaktadır. Redüktörler yağı doldurulmuş olarak sevkedilmektedir. Redüktörler uzun süre depolanacakları zaman veya çalışmaya başlanacağı zaman çalışma konumuna göre üstte kalan tapa sökülmeli ve redüktörün beraberinde verilen havalandırma tapası kullanılmalıdır. Bu redüktörün iç basıncından dolayı oluşacak yağ sızmalarını önleyecektir.

Redüktörlerde standart olarak kullanılan yağlar yan sayfadaki tabloda verilmiştir. Eğer Siparişte belirtilmezse M1 pozisyonuna göre yağ ile doldurulmuştur. Bu pozisyonlar dışındaki çalışma durumlarında tablolarda verilen yağ miktarlarına göre ilave veya eksiltme yapılmalıdır. Özel çalışma koşullarında firmamıza danışmanız tavsiye edilir.

Mineral yağlar her 10.000 çalışma saatinde, sentetik yağlar ise her 20.000 çalışma saatinde değiştirilmelidir. Ağır çevre koşullarında (ani ısı değişiklikleri, yüksek nemlilik v.b) yağ değiştirme periyotlarının kısaltılması tavsiye edilir. Mineral yağlar ile sentetik yağlar birbirine kesinlikle karıştırılmamalıdır. Değiştirme işlemi bir çalışma periyodunun hemen peşinden ve yağ sıcakken yapılmalıdır. Bu şekilde bir değiştirme, redüktör içindeki partiküllerin yağa karışmış olarak bulunmasından dolayı iyi bir temizleme ve yağın rahat boşalması neticesini verecektir.

Redüktörlerde kullanılan yağ tipi için etiketine bakınız.

#### Lubrication

*To work in perfect condition and to have long life for the gearbox the lubricant must be chosen correctly and changed in time.*

*In selection of oil it is important to consider speed, ambient temperature, gear box oil temperature, working conditions and the life required from the lubricant. All units are filled with lubricant before shipping. Before the gearbox is stored for a long time or before starting up, the top plug (according to the working position) must be removed and the extra given vent plug must be replaced. This prevents excessive pressure which causes oil leakages.*

*The lubricant in the standard line is given for standard fillings on the table below. If the mounting position not indicated on order filled with mounting position of M1. For other mounting positions please filling oil or draining oil refer to the table given on the next pages. For special working conditions please contact us.*

*The mineral lubricant should be changed after every 10.000 service hours and the synthetic lubricant should be changed after every 20.000 working hours. If the operation conditions are very heavy (e.g. high temperature differences, high humidity) shorter intervals between changes are recommended. Mineral and synthetic oils must not be mixed up. By changing the lubricant complete cleaning is advised. The oil change should be done after a working period. Because oil is hot in this condition and impurities are mixed with it the changing of oil will be done in best result and the oil will drain easily.*

*Please look at the label of your gear unit to check the filled oil type of gear unit.*

#### Schmierung

Um eine lange Lebensdauer zu gewährleisten muss der Schmierstoff richtig ausgewählt werden.

Für die richtige Ölauswahl müssen Drehzahl, Umgebungstemperatur, Belastungsart und Lebensdauer des Öls berücksichtigt werden. Die mitgelieferte Entlüftungsschraube ist vor Inbetriebnahme oder längeren Lagern gegen die Einfüllschraube auszutauschen, um einen Überdruck im Getriebe und damit eine Undichtigkeit des Getriebes zu vermeiden. Getriebe und Getriebemotoren sind bei Auslieferung betriebsfertig gefüllt.

Ohne besondere Bestellangaben werden die Getriebe grundsätzlich mit den auf der folgenden Seite in der grau unterlegten Spalte angegebenen Schmierstoffen gefüllt. Die fußbefestigten Getriebe sind befüllt für Bauform und für Bauform M1. Für andere Bauformen sind die auf der nächsten Seite angegebenen Füllmengen zu beachten.

Ein Schmierstoffwechsel sollte alle 10.000 Betriebsstunden durchgeführt werden. Für synthetische Produkte verdoppeln sich diese Fristen. Bei extremen Betriebsbedingungen, z.B. hohe Luftfeuchtigkeit, aggressiver Umgebung und hohen Temperatur-schwankungen sind kürzere Schmierstoffintervalle vorteilhaft. Es ist empfehlenswert, dem Schmierstoffwechsel mit einer gründlichen Reinigung des Getriebes zu verbinden. Synthetische und mineralische Schmierstoffe dürfen nicht miteinander vermischt werden. Das Ablassen des Öls soll unmittelbar nach dem Stillsetzen erfolgen, solange das Öl noch warm ist. In dieser Zustand ist das Öl mit den Smutzpartickeln vermischt, so dass eine Entfernung des Altöls eine gute Reinigung garantiert.

Bitte im Getriebe verwendetes Öl von dem Namensschild ablesen.



# Genel Bilgiler

## General Information

### Einführung



Yağ Cinsi Lubricant Art des Schmier	DIN 51517-3	Çevre Sıcaklığı (°C) Ambient Temperature (°C) Umgebungstemperatur (°C)		ISO VG	Aral	Beyond Petroleum	Castrol	Klüber Lubrication	Mobil	Shell	Total
		Daldırma Yağlama Dip Lubrication Tauchschmier.	Basınçlı Yağlama Forced Lubrication Druckschmier.								
Mineral Yağlar Mineral Oil Mineralöl	CLP	0 ... +50	-	680	Degol BG 680	Energol GR-XP 680	Alpha SP 680	Klüberoil GEM 1-680 N	Mobilgear 600 XP 680	Omala 680	Carter EP 680
		-5 ... +45	-	460	Degol BG 460	Energol GR-XP 460	Alpha SP 460	Klüberoil GEM 1-460 N	Mobilgear 600 XP 460	Omala F460	Carter EP 460
		-10 ... +40	+15 ... +40	320	Degol BG 320	Energol GR-XP 320	Alpha SP 320	Klüberoil GEM 1-320 N	Mobilgear 600 XP 320	Omala F320	Carter EP 320
		-15 ... +30	+10 ... +30	220	Degol BG 220	Energol GR-XP 220	Alpha SP 220	Klüberoil GEM 1-220 N	Mobilgear 600 XP 220	Omala F220	Carter EP 220
		-20 ... +20	+5 ... +20	150	Degol BG 150	Energol GR-XP 150	Alpha SP 150	Klüberoil GEM 1-150 N	Mobilgear 600 XP 150	Omala 150	Carter EP 150
		-25 ... +10	+3 ... +10	100	Degol BG 100	Energol GR-XP 100	Alpha SP 100	Klüberoil GEM 1-100 N	Mobilgear 600 XP 100	Omala 100	Carter EP 100
Sentetik Yağlar Synthetic Oil Synthetisches Öl	CLP PG	-10 ... +60	-	680	Degol GS 680	Energysyn SG-XP 680	-	Klübersynth GH 6 -680	Mobil Glygoyle 680	Tivela S 680	Carter SY 680
		-20 ... +50	-	460	Degol GS 460	Energysyn SG-XP 460	Aphasyn PG 460	Klübersynth GH 6 -460	Mobil Glygoyle 460	Tivela S 460	Carter SY 460
		-25 ... +40	+5 ... +40	320	Degol GS 320	Energysyn SG-XP 320	Aphasyn PG 320	Klübersynth GH 6 -320	Mobil Glygoyle 320	Tivela S 320	Carter SY 320
		-30 ... +30	0 ... +30	220	Degol GS 220	Energysyn SG-XP 220	Aphasyn PG 220	Klübersynth GH 6 -220	Mobil Glygoyle 30	Tivela S 220	Carter SY 220
		-35 ... +20	-5 ... +20	150	Degol GS 150	Energysyn SG-XP 150	Aphasyn PG 150	Klübersynth GH 6 -150	Mobil Glygoyle 22	Tivela S 150	Carter SY 150
		-40 ... +10	-8 ... +10	100	-	-	-	Klübersynth GH 6 -100	Mobil Glygoyle 100	-	-
	CLP HC	-10 ... +60	-	680	-	-	-	Klübersynth GEM 4-680 N	Mobil SHC Gear 680	-	Carter SH 680
		-20 ... +50	-	460	Degol PAS 460	Energysyn EP-XF 460	Alphasyn T 460	Klübersynth GEM 4-460 N	Mobil SHC Gear 460	Omala HD 460	Carter SH 460
		-30 ... +40	+5 ... +40	320	Degol PAS 320	Energysyn EP-XF 320	Alphasyn T 320	Klübersynth GEM 4-320 N	Mobil SHC Gear 320	Omala HD 320	Carter SH 320
		-40 ... +40	0 ... +30	220	Degol PAS 220	Energysyn EP-XF 220	Alphasyn T 220	Klübersynth GEM 4-220 N	Mobil SHC Gear 220	Omala HD 220	Carter SH 220
		-40 ... +40	-5 ... +20	150	Degol PAS 150	Energysyn EP-XF 150	Alphasyn T 150	Klübersynth GEM 4-150 N	Mobil SHC Gear 150	Omala HD 150	Carter SH 150
		-40 ... +40	-8 ... +10	100	-	-	-	Klübersynth GEM 4-100 N	Mobil SHC 627	-	-
Gıda Uyumlu Yağ Food Grade Oil Lebensmittelöl	CLP NSF H1	-30 ... +25	+5 ... +25	220	-	-	Optileb GT 220	Klüberoil 4 UH1-220 N	Mobil SHC Cibus 220	Cassida Fluid GL-220	Nevastane SL 220
Çevre Dostu Yağ Biodegradable Oil Biologisch abbaubares Öl	CLP E	-25 ... +40	+5 ... +40	320	-	-	Tribol BioTop 1418-320	Klübersynth GEM 2-320	-	-	Carter Bio 320
Mineral Gresler [ -20 ... +120 °C Çalışma Sıcaklığı ] Mineral Grease [ -20 ... +120 °C Working Temperature ] Mineral-Fett [ -20 ... +120 °C Betriebstemperatur ]					Aralub HL3	Energrease LS 3	Speherol AP3	Centoplex 2 EP	Mobilux EP 3	Alvania RL3	Multis Complex EP 2
Sentetik Gresler [ -30 ... +100 °C Çalışma Sıcaklığı ] Synthetic Grease [ -30 ... +100 °C Working Temperature ] Synthetisches Fett [ -30 ... +100 °C Betriebstemperatur ]					-	Energrease SY 2202	-	Petamo GHY 133 N	Mobiltemp SHC 100	Cassida RLS 2	Multis Complex SHD 220



# Genel Bilgiler

## General Information

### Einführung



#### Montaj Pozisyonları / Mounting Positions / Bauformen

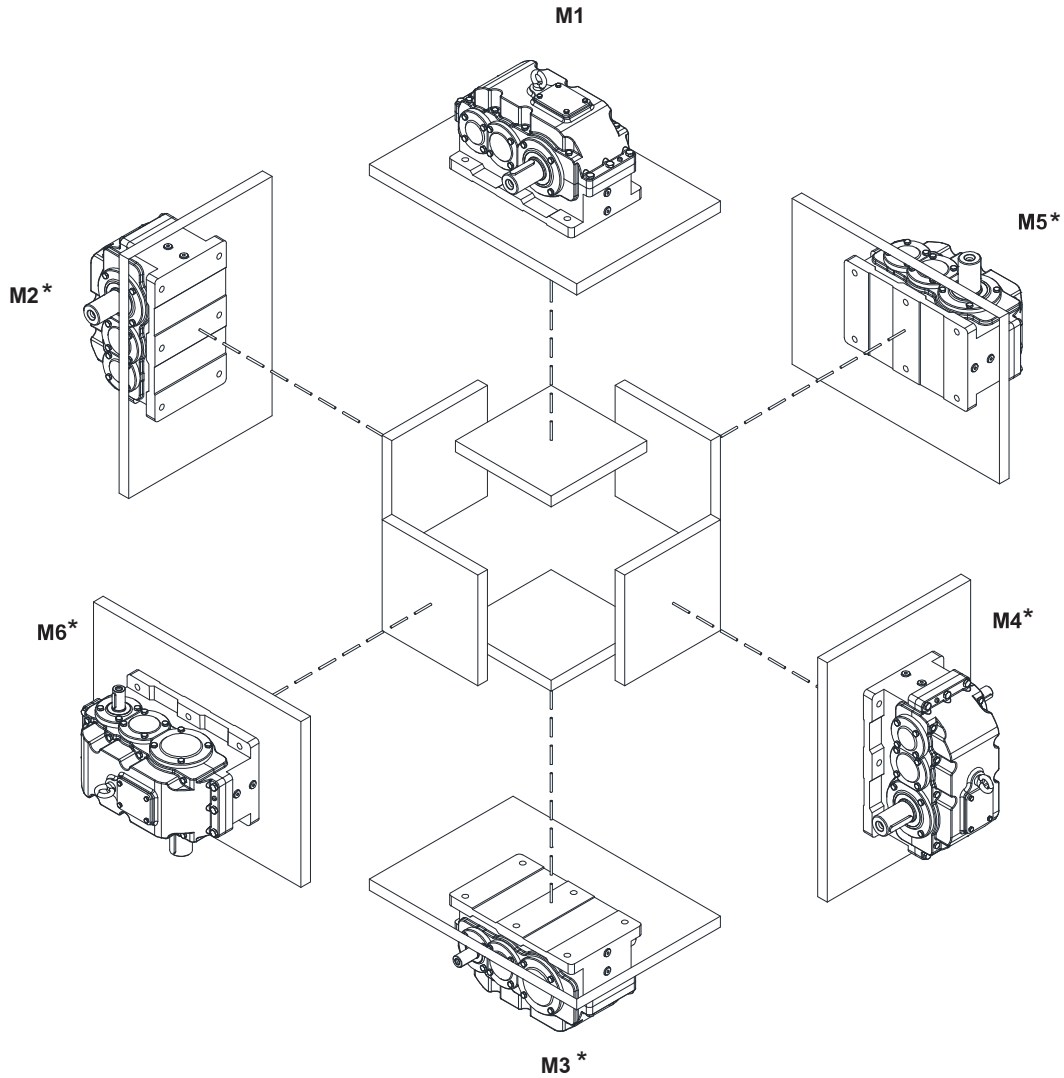

**M1....M6 'ya kadar belirtilen montaj pozisyonları redüktörün duruş yönü referans alınarak belirlenmiştir. Montaj yüzeyleri bağlayıcı değildir.**

*Figured mounting positions of M1 to M6 are determined as reference of directional position of the gearbox. Mounting surfaces are not binding.*

*Dargestellte Montagepositionen M1 bis M6 wurden nach der Stehrichtung von Getriebe bestimmt. Montageoberflächen sind unverbindlich.*

\* **Y serisi redüktörlerde M1 standart montaj pozisyonudur. Diğer montaj pozisyonları (M2,M3,M4,M5,M6) istendiğinde özel ürün kapsamında değerlendirilmektedir. Bu montaj pozisyonları gerektiğinde lütfen firmamıza danışınız.**

\* *M1 is standart mounting position of Y series gearunits. When other mounting positions (M2,M3,M4,M5,M6) are required please contact our company.*

\* *M1 Bauform ist Standard. Wenn andere Bauformen erfordert sind, melden Sie sich bitte bei unserer Firma.*



# Genel Bilgiler

## General Information

### Einführung

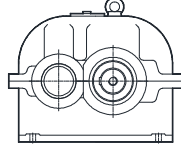
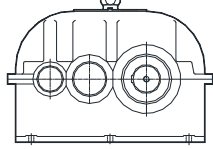
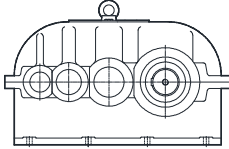
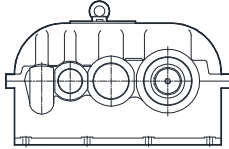

Yağ Miktarları (lt) / Oil Quantities (lt) / Ölmengen (lt)

Tip / Type / Typ	 M1	 M1	 M1	 M1
YRM1125	3.8	-	-	-
YRM1160	6.5	-	-	-
YRM1200	14	-	-	-
YRM2195	-	3.5	-	-
YRM2240/YRE2240	-	8.0/9.0	-	-
YRM2275/YRE2275	-	12/13	-	-
YRM2305/YRE2305	-	17/18	-	-
YRM2340/YRE2340	-	22/23	-	-
YRM2385 / YRE2385	-	29/30	-	-
YRM2430 / YRE2430	-	40/41	-	-
YRM2480 / YRE2480	-	64/65	-	-
YRM2545 / YRE2545	-	91/92	-	-
YRM3355	-	-	13	-
YRM3395	-	-	17	-
YRM3440	-	-	25	-
YRM3500	-	-	30	-
YRM3555	-	-	46	-
YRM3620	-	-	65	-
YRM3705	-	-	93	-
YRM4395	-	-	-	17
YRM4440	-	-	-	25
YRM4500	-	-	-	30
YRM4555	-	-	-	46
YRM4620	-	-	-	65
YRM4705	-	-	-	93



# Genel Bilgiler

## General Information

### Einführung



#### MOTORLAR

##### AC Motorlar

###### a- Genel Özellikler:

Basit konstrüksiyonlu, bakım gerektirmez, güvenilirliği yüksek ve uygun fiyatlı olmaları nedeni ile trifaze asenkron motorlar en çok kullanılan motor cinsidir. Bu motorların çalışma karakteristikleri moment-hız eğrisi ile belirlenir. Aşağıda bu karakteristik eğrisine bir örnek verilmiştir.

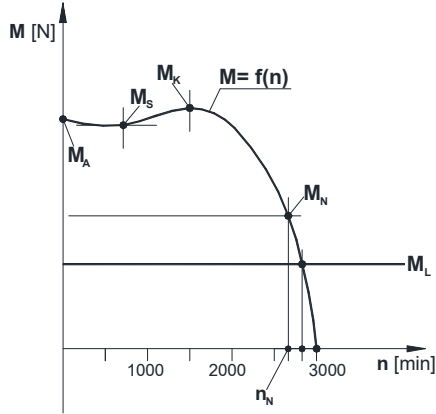

Motorun her start yapılmasında bu eğriye uygun hareket eder ve yük momentini  $M_L$  ile bu eğrinin çakıştığı nokta, motorun çalışma anındaki moment ve devirini verir.

Statorun manyetik alanı senkron hızla  $n_s$  döner. Kutuplar arasındaki faz kayması 3 fazlı motorlarda  $120^\circ$  dir.

$$n_s = 120 \times \frac{f}{p_s}$$

f.....: şebeke frekansı [Hz]  
p\_s.....: statorun kutup sayısı

Rotorun değişken manyetik alanı rotorun statorun manyetik alanının dönüşü yönünde dönmeye başlamasını sağlar. Rotor bu hareketinde statorun manyetik alanını takip eder ama hiçbir zaman yakalayamaz. Rotor statorun manyetik alanının hızından yavaş döner. Rotorun bu hızına baz hız  $n_N$  denir. Yükün azalması rotorun hızının artmasını sağlar, aynı zamanda sapma azalmış olur. Sapma aşağıdaki gibi belirlenmiştir:

$$s = \frac{n_s - n_N}{n_s} \times 100$$

Sapmanın miktarına göre motorun nominal değerlerinde şu farklılıklar olabilir.

Sapma s .....:  $\pm 20\%$   
Kalkış Akımı.....:  $\pm 20\%$   
Kalkış Momenti.....:  $-15 / +25\%$   
Kütle Atalet Momenti.....:  $\pm 10\%$   
Verim (37 kW'a kadar).....:  $-0,15 (1-\eta)$

#### MOTORS

##### AC Motors

###### a- General Specifications:

On account of its simple and maintenance free construction, good reliability and price, the three phase squirrel cage motor is one of the most frequently employed electric motors. The run up behavior of a three phase squirrel cage motor is described by the torque-speed characteristic curve. An example is shown below.

$M_A$ : Start momenti / Starting torque / Anlaufmoment

$M_S$ : Demeraj momenti / Pull-up torque / Anziehungsmoment

$M_K$ : Frenleme momenti / Pull-out torque / Bremsungsmoment

$M_N$ : Motorun ilettiği moment / Motor rated torque / Treibmoment

$M_L$ : Yük momenti / Load torque / Lastmoment

The motor follows this torque characteristics up to its stable operating point every time, when it is switched on. Operating point is that point, where the moment speed curve intersects with load torque  $M_L$  line.

The magnetic field in the stator rotates at a synchronous speed  $n_s$ . Phase shift of each pole is  $120^\circ$  at 3 phase motors.

$$n_s = 120 \times \frac{f}{p_s}$$

f.....: supply frequency [Hz]  
p\_s.....: number of stator poles

Because of the alternating magnetic field in the rotor, the rotor starts running in the same direction of the stator flux and tries to catch up with the rotating flux. The rotor never catches up with the stator field. The rotor runs slower than the speed of the stator field. This speed is called the base speed  $n_N$ .

A decrease in load will cause the rotor to speed up or decrease slip. The slip is defined as follows:

$$s = \frac{n_s - n_N}{n_s} \times 100$$

According to the slip, the nominal values of the electric motor can alter as follows:

Slip s .....:  $\pm 20\%$   
Starting current .....:  $\pm 20\%$   
Starting torque .....:  $-15 / +25\%$   
Moment of inertia.....:  $\pm 10\%$   
Efficiency (up to 37 kW).....:  $-0,15 (1-\eta)$

#### MOTOREN

##### Drehstrommotoren:

###### a- Allgemeine Eigenschaften

Wegen der wartungsarmen und leichten Konstruktion, hoher Sicherheit bei Nutzung und günstiger Preise werden die asynchrone Drehstrommotoren am meisten benutzt. Motoranlaufverhalten wird mit Moment-Drehzahl-Kurve charakterisiert. Ein Beispiel ist unten angegeben.

Der Drehstrommotor läuft diese Kurve bei jedem Anlauf, bis der stabile Betriebspunkt erreicht wird. Betriebspunkt ist der Zustand, bei dem die Moment-Drehzahl-Kurve sich mit der Linie von erforderlichen Moment  $M_L$  schneidet. Magnetisches Feld von Stator dreht sich mit synchroner Geschwindigkeit  $n_s$ . Phasenverschiebung von den Polen ist  $120^\circ$  bei 3 phasigen Drehstrommotoren.

$$n_s = 120 \times \frac{f}{p_s}$$

f.....: Frequenz der Spannung [Hz]  
p\_s.....: Anzahl der Polen von Stator

Durch das magnetische Wechselfeld in den Rotor, beginnt der Rotor sich in der gleichen Richtung des Statorflusses zu drehen und versucht diese Bewegung aufzuholen. Der Rotor kann den Statorfeld nie aufholen. Die Rotorgeschwindigkeit nennt man Basisgeschwindigkeit  $n_N$ . Eine Abnahme der Belastung bewirkt, dass der Rotor sich beschleunigt und der Schlupf sich verringert. Der Schlupf wird wie folgt definiert:

$$s = \frac{n_s - n_N}{n_s} \times 100$$

Für die nominale Werte der Drehstrommotoren sind folgende Abweichungen zulässig:

Schlupf s .....:  $\pm 20\%$   
Anzugsstrom .....:  $\pm 20\%$   
Anzugsmoment .....:  $-15 / +25\%$   
Massenträgheitsmoment .....:  $\pm 10\%$   
Wirkungsgrad (bis 37 kW).....:  $-0,15 (1-\eta)$





# Genel Bilgiler

## General Information

### Einführung



#### b- Çalışma Türleri

Katalogta verilen tüm redüktörlerin motorları S1 çalışma türüne uygun verilmektedir. Diğer çalışma türleri aşağıdaki tabloda gösterilmiştir.

#### b-Modes of Operation

All motors of the catalogue have been laid out for duty S1 (continuous operation). Other duty types are given on the following table.

#### b-Betriebsarten

Die im Katalog angeführten Motoren sind für Betriebsart S1 (Dauerbetrieb) ausgelegt. Andere Betriebsarten sind unten angegeben.

Çalışma Türü Operation Betriebsarten	Açıklama Explanation Erläuterung	Yük Grafiği Load Graphic Lastverläufe
S1	<b>Sabit yükte sürekli çalışma</b> Continuous operation under constant load Dauerbetrieb mit konstanter Belastung	
S2	<b>Sabit yükte kısa süreli çalışma</b> Short-time duty under constant load Kurzbetrieb mit konstanter Belastung	
S3	<b>Yolvermede sıcaklık artımı olmadan periyodik çalışma</b> Periodic duty without influence of start-up on temperature Aussetzbetrieb ohne Einfluß des Anlaufens auf die Temperatur	
S4	<b>Yolvermede sıcaklık artımı olan periyodik çalışma</b> Periodic duty with influence of start up on temperature Aussetzbetrieb mit Einfluß des Anlaufens auf die Temperatur	
S5	<b>Yolvermede ve frenlemede sıcaklık artımlı periyodik çalışma</b> Periodic duty with influence of startup and braking on temp. Aussetzbetrieb mit Einfluß des Anlaufens / Bremsung auf die Temp.	
S6	<b>Sürekli orta darbeleri çalışma</b> Continuous operation with intermittent loading Durchlaufbetrieb mit Ausetzungsbelastung	
S7	<b>Elektriksel frenlemeli sürekli orta darbeleri çalışma</b> Continuous operation with intermittent loading and braking Ununterbrochener Betrieb mit Anlauf und Bremsung	
S8	<b>Devir ve yük değişimli sürekli çalışma</b> Continuous operation duty type with related load-speed changes Ununterbrochener periodischer Betrieb mit Drehzahländerung	



# Genel Bilgiler

## General Information

### Einführung



#### c- Koruma Sınıfı:

Yılmaz Redüktörde standart olarak IP54 (IEC 34-5) koruma sınıfı motorlar kullanılmaktadır. Diğer koruma sınıfları istendiğinde firmamıza danışınız.

#### d- İzolasyon Sınıfı:

Yılmaz Redüktörde kullanılan standart izolasyon sınıfı F (IEC 317-8) dir. İstek üzerine H sınıfı yapılabilmektedir.

#### e- Verim Sınıfları:

Üç fazlı az gerilim asenkron motorların verim sınıfı ölçümü IEC 60034-2-1:2007 normu ile belirlenmiştir. Yeni IE verim sınıfı 0,75 kW'tan 375 kW'a kadar güç aralığında çalışan AC motorlar için geçerlidir. EFF verim sınıfından farklı olarak IE verim sınıfı 6 kutup sayılı motorlar içinde kullanılabilir. Aşağıda verim sınıfları sıralanmıştır. Bölgeler dışında verim sınıfı zorunlulukları ülkelere görede farklılık gösterebilir. Lütfen firmamıza danışınız. Başka ürünlere entegre olmuş ve bu nedenle motorun veriminin bağımsız belirlenemediği sistemlerde (redüktör pompa gibi) verim sınıflandırması geçerli değildir.

#### c- Protection Class:

Yılmaz Redüktör uses IP54 (IEC 34-5) protection class electric motors for standard products. If different kind of protection class is requested please contact us.

#### d- Insulation Class:

Yılmaz Redüktör uses F (IEC 317-8) insulation class electric motors for standard products. H insulation class is available upon request.

#### e- Efficiency Classes:

The method for measuring the efficiency of low voltage three-phase asynchronous motors was revised with the new IEC 60034-2-1:2007 standard. The new IE classes is valid for AC Motors in power range from 0,75 to 375 kW. Unlike the EFF classes IE classes can be used for 6-pole AC motors. Below is the table of efficiency classes. The instructions for efficiency classes can differ from country to country. Please contact with us for more information. For the motors, which are fully integrated into a product (for example gear, pump) so their energy efficiency can not be recognized independently, the requirements of efficiency are not valid in Europe.

#### c- Schutzarten:

Yılmaz Redüktör Getriebemotoren werden serienmäßig mit Schutzart IP54 (IEC34-5) ausgeführt. Für andere Schutzarten bitte rückfragen.

#### d- Isolationsklasse:

Yılmaz Redüktör Getriebemotoren werden serienmäßig in Wärmeklasse F (IEC317-8) ausgeführt. H Wärmeklasse ist möglich auf Kundenwunsch.

#### e- Energieeffizienzklassen:

Die Methode für Messung die Effizienz von drei phasigen gering Spannung Asynchronmotoren hat neu mit IEC 60034-2-1:2007 Norm festgestellt. Die neue IE-Klassen gelten für alle Drehstrommotoren im Leistungsbereich von 0,75 bis 375 kW. Anders als EFF-Klassen die IE-Klassen können auch für 6-polige Drehstrommotoren verwendet werden. Unten steht die Tabelle der Effizienzklassen. Die Richtlinien für Effizienzklassen können sich je nach dem Land unterscheiden. Bitte mit unserem Firma Kontakt aufnehmen. Für die Motoren, die vollständig in ein Produkt (zum Beispiel Getriebe, Pumpe) eingebaut sind und deren Energieeffizienz nicht unabhängig von diesem Produkt erfasst werden kann, gelten in Europa die Anforderungen der Effizienzklassen nicht.

Verim Sınıfları Efficiency Classes Energieeffizienzklassen			4 Kutuplu Motor Verim Değeri Hesabı Calculating Efficiency Values of Motors with 4 Poles Berechnung der Wirkungsgrade von Elektromotoren mit 4 Polen	
IE1	EFF 2	<b>Standart Verim</b> Standart Efficiency Standarte Energieeffizienz	A=0,5234 B=-5,0499 C=17,4180 D=74,3171	$\eta_{Mn} = A \times [\log_{10}(P_L)] + B \times [\log_{10}(P_L)]^2 + C \times \log_{10}(P_L) + D$ <p><math>P_L</math> :Anma Yüğü [kW] / Nominal Load [kW] / Nennlast [kW]</p> <p><math>\eta_{Mn}</math> :Nominal verim / Nominal Efficiency [kW] / Sollwirkungsgrad</p>
IE2	EFF 1	<b>Yüksek Verim</b> High Efficiency Hohe Energieeffizienz	A=0,0278 B=-1,9247 C=10,4395 D=80,9761	
IE3	-	<b>Premium Verim</b> Premium Efficiency Premium Energieeffizienz	A=0,0773 B=-1,8951 C=9,2984 D=83,7025	
IE4	-	<b>Süper Premium Verim</b> Super Premium Efficiency Super Premium Energieeffizienz	-	

4 Kutuplu Motor Verim Değerleri Efficiency Values of Motor with 4 poles Sollwirkungsgrad des Motors mit 4 Polen	Anma Yüğü [kW] Nominal Load [kW] Nennlast [kW]	Verim Sınıfı / Efficiency Class / Energieeffizienzklassen		
		IE1	IE2	IE3
	0,75	72,1 %	79,6 %	82,5 %
	1,5	77,2 %	82,8 %	85,3 %
	3	81,5 %	85,5 %	87,7 %
	7,5	86 %	88,7 %	90,4 %
	15	88,7 %	90,6 %	92,1 %
	22	89,9 %	91,6 %	93 %
	37	91,2 %	92,7 %	93,9 %
	45	91,7 %	93,1 %	94,2 %
	75	92,7 %	94 %	95 %
	90	93 %	94,2 %	95,2 %
	330	94 %	95,1 %	96 %



# Genel Bilgiler

## General Information

### Einführung



#### f- AC Frekans İnvörtörler

Doğru Akımı (DC), alternatif akıma (AC) çeviren elektronik çeviricilere İnvörtör denilmektedir. AC motorlar için elektronik hız kontrol cihazları genellikle AC giriş akımını doğrultucu diyotlarla DC akıma çevirir ve daha sonra çevirici diyotlar vasıtasıyla bu akımı tekrar AC akıma çevirir. Doğrultucu diyotlar ile çevirici diyotlar arasındaki bağlantı DC-bağ olarak tanımlanmaktadır. DC kontrol cihazının (genellikle İnvörtör olarak isimlendirilir) elektriksel blok şeması aşağıda verilmiştir.

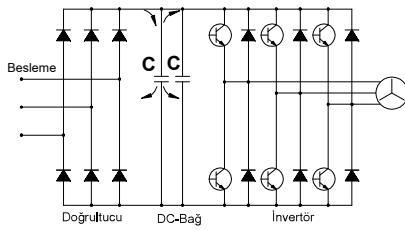

Tam dalga doğrultucuları besleyen üç faz besleme akımı DC-bağ kapasitörlerine iletilir. Kapasitörler voltajdaki dalgalanmaları azaltır ve kısa süreli ağdaki akım kesintilerinde enerji sağlar. Kapasitörlerdeki voltaj kontrolsüzdür ve gelen AC akımın pik akım değerlerine bağlıdır. DC akım tekrar AC akıma, Puls genişliği modülasyonu (PWM) kullanılarak çevrilir. İstenen dalga formu, sabit bir frekansta (Puls frekansında), çıkış transistörlerinin (İzole edilmiş geçit Bipolar transistörleri; IGBT 'ler) açılıp kapatılması ile oluşturulur. IGBT'lerin açma kapanma zamanlarının değişimi ile istenen akım oluşturulabilir. Çıkış voltajı bir seri kare dalga pulslardır ve motor sargılarının İndüktansı ile sinüsoidal bir motor akımı oluşur. Puls genişliği modülasyonu aşağıda gösterilmiştir.

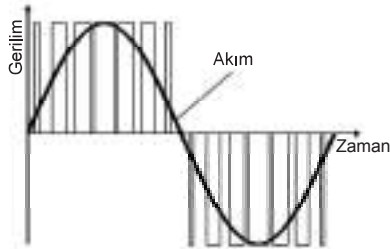

#### f- AC Frequency Inverters

An electronic converter is a device which converts Direct Current (DC) to Alternating Current (AC) is known as an inverter. Electronic speed controllers for AC motors usually convert the AC supply to DC using a rectifier, and then convert it back to a variable frequency, variable voltage AC supply using an inverter bridge. The connection between the rectifier and inverter is called the DC link. The block diagram of a speed controller (often called an inverter) is shown below.

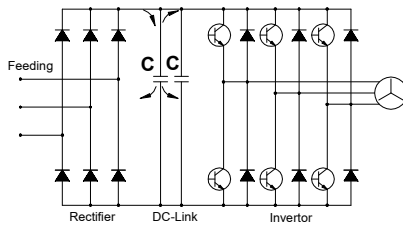

The three phase supply is fed into a full wave rectifier which supplies the DC link capacitors. The capacitors reduce the voltage ripple (especially on single supplies) and supply energy for short mains breaks. The voltage on the capacitors is uncontrolled and depends on the peak AC supply voltage. The DC voltage is converted back to AC using Pulse Width Modulation (PWM). The desired waveform is built up by switching the output transistors (Insulated Gate Bipolar Transistors; IGBTs) on and off at a fixed frequency (the switching frequency). By varying the on and off time of the IGBTs the desired current can be generated. The output voltage is still a series of square wave pulses and the inductance of the motor windings results in a sinusoidal motor current. Pulse Width Modulation is shown in the figure below.

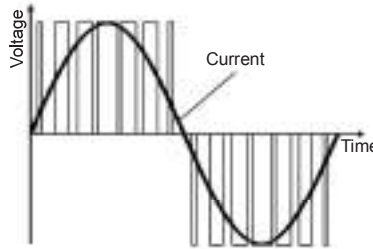

#### f- AC Frequenz Umrichter

Ein elektronischer Wandler, der den Gleichstrom (DC) in Wechselstrom (AC) umwandelt, wird als Umrichter bezeichnet. Ein Frequenzumrichter benutzt einen ungesteuerten Eingangsgleichrichter, um die Netzspannung in Gleichspannung umzuwandeln. Diese wird dann in den Zwischenkreiskondensatoren gespeichert. An diesem Gleichspannungszwischenkreis ist ein Wechselrichter angeschlossen. Dieser Wechselrichter erzeugt am Ausgang eine variable Frequenz und eine variable Spannung. Der Anschluss zwischen dem Gleichrichter und dem Wechselrichter nennt man Gleichstromverbindung. Das Blockschaltbild von diesem System wurde unten dargestellt:

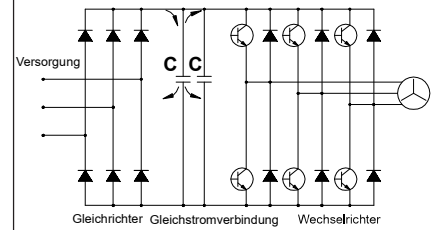

Auch bei dreiphasiger Versorgung wird die gleichrichtete Netzspannung den Zwischenkreiskondensatoren zugeführt. Die Kondensatoren reduzieren die Oberwelligkeit der Spannung (was besonders bei einphasiger Versorgung entscheidend ist) und liefern Energie, die kurze Unterbrechungen der Netzstromversorgung ermöglicht. Die Spannung der Kondensatoren ist vom Spitzenwert der Wechselspannung abhängig. Die Gleichspannung wird im Wechselrichter durch Pulsweitenmodulation (PWM) in Wechselspannung umgewandelt. Die gewünschte Wellenform wird durch Ein- und Ausschalten der Ausgangstransistoren (IGBT's Isolierte Gate Bipolar Transistoren) mit einer festen Frequenz (der Pulsfrequenz) erzeugt. Der gewünschte Strom kann durch die Variation der Ein- und Ausschaltzeit der Ausgangstransistoren generiert werden. Die Ausgangsspannung ist dadurch eine Reihe von Spannungsimpulsen, die in Verbindung mit der Induktivität der Motorspulen zu einem sinusförmigen Motorstrom führt. Die Pulsweitenmodulation wird wie folgt dargestellt

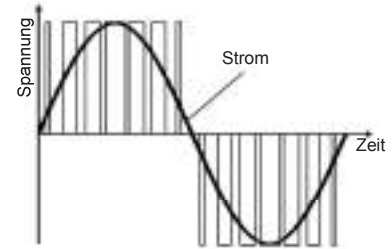



# Genel Bilgiler

## General Information

### Einführung



#### DC MOTORLAR

##### a- Genel Özellikler

DC motorlar, elektronik parçalardaki gelişmeler nedeni ile yeni uygulama alanları bulmuştur. Daha önce çok pahalı olan ve ekonomik olmayan kontrol sistemlerinin yerini ucuz ve kompakt güç kontrol üniteleri almıştır. Yol vermenin kontrol altına alınabildiği, tork ve akım izlenebilirliği, aşırı yüklenmeye karşı elektronik koruma sağlanabilmesi ve daha birçok pahalı olmayan uygulamalar DC motorlarını cazip kılmaya başlamıştır.

##### b- DC Motorların Çalışma İlkeleri

DC motorlar için DC çıkış veren bir doğrultucuya ihtiyaç vardır. Motor armatür sargıları, alan sargıları, komutasyon sargıları ve kompanse sargılar olmak üzere rotorda ve statorda bulunan sargılardan oluşur. Rotora voltaj ve akım karbon fırçalar ve komutator sargılarla ulaştırılır. Bu karbon fırçalar aşındığından DC motorlar belirli periyotlarla bakıma alınmalıdır. İyi kontrol edilebilir özelliklerinden dolayı DC motorlar otomasyon teknolojisinde sıkça kullanılmaktadır.

##### c- DC Motor Çeşitleri

Temel olarak Şönt (Shunt) ve seri sargılı DC motorlar bulunmaktadır. Bu sargıların çeşidine göre moment eğrisi değişmektedir.

##### d- DC Motorlarda Hız Kontrolü

Bu motorlarda devir değişimi DC voltajın değiştirilmesi ile yapılır. Şönt sarımlı DC motorların sıfır yük ile maksimum yük arasındaki davranışı AC motorlara benzer. Devir artan yükte beraber düşer. Bu devir farkı ufak güçlü motorlarda büyük, büyük güçlü motorlarda ise ufaktır. Fakat bu hız farkı DC doğrultucu cihazda armatür voltajı ( $I \times R$ ) ile oynanarak kompanse edilebilir. Hassas hız kontrol gereksinimi olduğunda, tako jeneratörler kullanılabilir. DC motorların gücü aşağıdaki formülden hesaplanır;

$$P_g = U \times I = \frac{P_c}{\eta}$$

$P_g$  : Giriş gücü W  
 $P_c$  : Çıkış gücü W  
U : Armatür gerilimi V  
I : Armatür akımı A  
 $\eta$  : Motor verimi

#### DC MOTORS

##### a- General Specifications of DC Motors

*DC drive systems have found new possible applications with the development of the electronic components sector. What was previously extremely expensive and in some cases not economically feasible is nowadays realized by miniaturised power converter technology. Additional functions such as guided startup after a predetermined time, torque and current monitoring with electronic protection against overloading, and many inexpensive special applications have made DC drive systems more attractive.*

##### b- Operating principles of the DC Motors

*The DC motor requires, a converter with DC output. The motor includes windings, such as armature, field, commutation and compensation windings, which are arranged in the stator as well as on rotor. Voltage and current are supplied to the rotor via the carbon brushes and the commutator. The carbon brushes are wearing parts therefore a DC motor requires maintenance at service intervals. While its good control properties, the DC motor is an essential item in automation technology.*

##### c- Types of DC Motors

*Depending on the wiring of the exciting winding or field winding, two basically different variants are regards torque speed characteristics may be distinguished.*

##### d- Speed Control of DC motors

*In DC motors the speed is adjusted by altering the DC voltage. DC shunt wounded motors behave similar to three phase induction motors between no load operation and maximum load. The speed drops with increasing loading of the motor. This difference is greater in small motors and smaller in larger motors. The speed difference can be compensated in the DC converter device by adjusting ( $I \times R$ ). If great control accuracy is required, a speed control with measurement of the actual values by a tachogenerator can be used. The power of DC motor;*

$$P_g = U \times I = \frac{P_c}{\eta}$$

$P_g$  : Input Power W  
 $P_c$  : Output Power W  
U : Armature Voltage V  
I : Armature Current A  
 $\eta$  : Motor efficiency

#### DC MOTOREN

##### a- Eigenschaften von DC Motoren

Mit den Entwicklungen bei elektronischen Komponenten haben DC Motoren neue Anwendungsbereiche gefunden. Regelungssysteme, die früher sehr teuer und im manchen Anwendungsfällen ungünstig waren, sind jetzt kompakt und günstig. Bei den DC Motoren ist kontrolliertes Anlauf, Moment- und Stromüberwachung mit Überlastschutz möglich. Es gibt viele günstige Sonderanwendungen für diese Motoren. Wegen oben genannten Eigenschaften werden die DC Motoren immer mehr bei unterschiedlichen Anwendungen benutzt.

##### b- Funktionsprinzip der DC Motoren

Bei DC Motoren ist eine Kommutatorwicklung im Rotor angeordnet, während der magnetische Fluss vom Stator erzeugt wird. Dies kann wiederum mittels einer Erregerwicklung oder durch Permanentmagnete geschehen. Wie bei der Synchronmaschine wird durch das Erregerfeld in der Ankerwicklung eine Wechselfeldspannung, die bei der Gleichstrommaschine jedoch durch den mechanischen Kommutator und die darauf schleifenden Bürsten in eine Gleichspannung umgeformt wird, induziert.

##### c- Arten von DC Motoren

Es gibt zwei verschiedene Wicklungen, nämlich Shunt- und Serial-Wicklung. Das Drehmoment-Drehzahl-Verhältnis ist für beide Wicklungen unterschiedlich.

##### d- Drehzahl Kontrolle für DC Motoren

Drehzahl von DC Motoren kann man mit Steuerung der DC Spannung ändern. DC Motoren mit Shunt Wicklungen ist ähnlich zu drei phasen AC Motoren zwischen maximalen Last und ohne Last. Drehzahl wird mit der Last reduziert. Mit kleineren Motoren wird dieser Differenz höher mit größeren Motoren kleiner. Der Drehzahlunterschied kann geregelt werden mit ( $I \times R$ ) Veränderung. Wenn eine genaue Kontrolle gebraucht, soll ein Tachogenerator benutzt werden. Leistung des DC Motors;

$$P_g = U \times I = \frac{P_c}{\eta}$$

$P_g$  : Eingangsleistung W  
 $P_c$  : Ausgangsleistung W  
U : Ankerspannung V  
I : Ankerstrom A  
 $\eta$  : Wirkungsgrad des Motors





# Genel Bilgiler

## General Information

### Einführung



#### Elektromanyetik Frenler

Bu tip frenlerin iki sürtünme yüzeyi vardır. Fren torku, voltaj uygulanmadığı zaman yayların kuvveti ile oluşturulur. Fren elektromanyetik alanın oluşumu ile serbest kalır. Bobinin beslenmesi ile mıknatıslanan balata baskı pulu, elektromıknatısa doğru çekilir. Bu hareket yayları baskı altına alır ve rotor mili üzerine takılan çoklu kama üzerinde aksiyal yönde serbest hareket edebilen balata serbest kalır. Akım kesildiğinde yayların baskısıyla, balata baskı pulu fren balatasına doğru itilir ve bu hareket rotoru frenler.

#### Fren Çeşitleri

##### a) Soğutmasız tip frenler

Motor fanı çıkarılıp motor kapağı arkasına akupile edilerek kullanılan frenler; genellikle sıkça açılıp kapanmayan ve kısa zaman aralıklarında çalışan sistemlerde tercih edilir.

##### b) Soğutmalı tip frenler

Motor fanı çıkarılıp motor kapağı arkasına akupile edilen ve motorun mili uzatılarak fren ve motorun arkasına alınan fan sayesinde daimi bir hava sirkülasyonu sağlanarak kullanılan frenlerdir. Genellikle uzun süreli çalışan ve kapalı mekanlarda kullanılan sistemlerde tercih edilirler.

##### c) Manuel kol sistemli frenler

Çalışma sistemi olarak her iki fren tipinde de kullanılabilir (soğutmalı veya soğutmasız). Özel durumlarda (elektrik kesilmesi; mekanik problemler) üzerinde bulunan bir kol vasıtası ile sistemi yay baskısından kurtararak serbest kalmasını sağlayan frenlerdir. Genellikle manuel olarak sistemin açılması gereken yerlerde (otomatik giriş kapıları, dış cepe boyama asansörleri v.b.) tercih edilir.

#### Fren çalışma voltajları

Elektromanyetik frenler 230V AC veya 400V AC beslemeli olarak sipariş edilebilir. Frenler DC fren olmaları nedeniyle ile besleme ile fren bobini arasında fren tipine bağlı olarak, yarım dalga, tam dalga doğrultucular veya trafolar kullanılır. Özel olarak belirtilmedikçe 230V beslemeli ve yarım dalga doğrultuculu frenler kullanılmaktadır. Özel durumlar için YILMAZ Redüktöre danışınız.

##### a) 98V DC Frenler:

Motor klemens kutusundan alınan 230V'luk AC besleme yarım dalga doğrultucu ile 98V DC'ye dönüştürülür. Fren bobin DC voltajı etiketi üzerinde belirtilmiştir.

##### b) 198V DC Frenler

Motor klemens kutusundan alınan 400V'luk AC besleme, yarım dalga doğrultucu ile 198V DC'ye düşürülür. Fren bobininin DC voltajı etiket üzerinde belirtilmiştir.

##### c) 24V DC Frenler

Kullanılan fren momentinin büyüklüğüne göre besleme transformatörü seçilir. Şebekeden veya motorun klemens kutusundan alınan besleme voltajı transformatörde 29 V'a çevrilen gerilim tam dalga doğrultuculardan geçerek 24V DC'ye çevrilir ve fren bobini beslenir. İstenirse 24 VDC güç kaynağı da kullanılabilir.

#### Electromagnetic Brakes

*This type of brakes has two friction surfaces. Brake torque is generated by springs when no voltage is applied. The brake is electromagnetically released. On exciting the electromagnet means of the current, the armature plate is pulled towards the electromagnet itself, thrust loading the pressure spring and enabling the friction disc which is axially movable on the key, to turn freely. When current fails, the pressured springs drive the armature plate towards the disc, thus braking the motor shaft.*

#### Brake Types

##### a) Brakes without cooling

*This type of brakes are assembled on the back cover of the electric motor. There is no fan on the backside. This brake type is mostly preferred in short working times and short working cycles.*

##### b) Fan cooled brakes

*This type of brakes are assembled on the back cover of electric motor by removing the electric motor fan. A fan is coupled to the backside of the electric motor. Fan cooled brakes are preferred in long working times and closed places without airflow.*

##### c) Brakes with hand release

*This brakes can be released by help of an arm. It can be applied to both of the above mentioned brakes and used in special cases (fail of electric current, mechanical problems etc.) These brakes are mostly preferred if operation (re-lasing) without a current is needed (automatic controlled doors, gates, building wall painting elevators etc.).*

#### Working Voltages

*Electromagnetic brakes can be ordered with 230V AC or 400V AC supply voltage. The coil of brakes needs DC voltage and therefore depending on brake type a half wave, a full wave rectifier or transformer should be used between supply and coil voltage. As standard the brakes will be delivered with 230V supply voltage and half wave rectifier, if there is no special request. For special cases please contact YILMAZ Redüktör.*

##### a) 98V DC Brakes:

*230V AC supply voltage from the motor terminal box reduces to the 98V DC with half-wave rectifier. DC brake coil voltage is indicated on the label.*

##### b) 198V DC Brakes:

*400V AC supply voltage from the motor terminal box reduces to the 198V DC with half-wave rectifier. DC brake coil voltage indicated on the label.*

##### c) 24V DC Brakes

*The transformer's size is selected according to value of brake torque. The current is taken from the electric motor terminal box or from the electric panel and is transformed to 29V DC current. This current is transferred to 24V DC current with full-wave rectifier and supplies brake coil. Separated 24V DC Power supply usable.*

#### Elektromagnetische Bremsen

Die Bremse hat zwei Reibflächen und arbeitet nach dem Ruhestromprinzip. Im stromlosen Zustand wird das Bremsmoment durch den Druck der Feder erzeugt, während die Bremse beim Betrieb elektromagnetisch losgelassen wird. Durch die Erregung der Elektromagneten wird die Ankerscheibe zu den Elektromagneten gezogen und die Feder zusammengedrückt. Dadurch kann sich die Bremsscheibe, die axial beweglich auf dem Mitnehmer angeordnet ist, frei drehen. Wird der Strom unterbrochen, drücken die Feder die Ankerscheibe gegen die Bremsscheibe und halten die Motorwelle an.

#### Bremsearten:

##### a) Bremsen ohne Kühlung

Diese Bremsen sind für Kurzlaufzeiten geeignet. Die Lüfterhaube und Lüfter des Motors ist ausgebaut und die Bremse ist an dem Ende der Motorwelle befestigt.

##### b) Bremsen mit Kühlung

Diese Bremsen sind für lange Laufzeiten und kleine, abgedeckte Räume geeignet. Durch die Verlängerung der Motorwelle wurde Lüfter hinter dem Bremse und dem Motor verbunden. Somit wurde eine konstante Lüftung ermöglicht.

##### c) Bremsen mit Hebelarm

Diese Bremsenart kann mit oder ohne Kühlung verwendet werden. Diese Bremsen sind bei der speziellen Fälle, wie keine Spannung an der Leitung, mechanische Probleme usw., anwendbar. Die Bremse wird mit einem Hebelarm manuell betätigt. Diese Bremsen werden am meisten an den Stellen, wo die Lüftung ohne Spannung erfolgen soll, benutzt (automatische Türe, Wandaufzüge).

#### Betriebsspannungen

Elektromagnetische Bremsen können mit 230V AC oder 400V AC Versorgungsspannung bestellt werden. Die Wicklungen der Bremsen brauchen Gleichspannung und deswegen abhängig von Bremsenart zwischen Versorgungsspannung und Wicklungsspannung soll Halbwellen-, Vollweggleichrichter oder Transformator verwendet werden. Als Standard die Bremsen werden mit 230V Versorgungsspannung und Halbwellengleichrichter geliefert.

##### a) 98V DC Bremsen

230V AC Versorgungsspannung von Klemmenkasten wird auf die Wicklungsspannung 98V DC mit Halbwellengleichrichter reduziert. Wicklungsspannung ist auf dem Etikett angegeben.

##### b) 198V DC Bremsen

400V AC Versorgungsspannung von Klemmenkasten wird auf die Wicklungsspannung 198V DC mit Halbwellengleichrichter reduziert. Wicklungsspannung ist auf dem Etikett angegeben.

##### c) 24V DC Bremsen

Die Spannung wird von den Klemmenkasten des Motors oder Elektrikschrank entnommen. Diese Spannung wird zuerst mittels Transformator zu 24 V reduziert. Danach wird diese Spannung mit Hilfe von Gleichrichter zu Gleichstromspannung umgewandelt. Die Größe des Transformators ist abhängig von der Größe des Bremsmoments. Es kann auch ein 24V DC Netzgerät benutzt werden.





# Genel Bilgiler General Information Einführung



## d) Şok ikazlı trafolar

Büyük güçteki ve momentteki frenlerin man-yetik doyuma ulaşmaları uzun zaman alır. Şok ikazlı trafolar frenin yay baskısını yenmede gecikmesini engellemek için kullanılır ve zaman rölesi yardımı ile çok kısa bir süre normal besleme voltajının iki katı ile (48V DC) beslenip sistemin ani açılmasını sağlar. Bu sayede gecikmeli açılmada ortaya çıkacak sürtünmeyi engellemeye yarayan bir trafo şeklindedir.

## Fren bağlantı şekli

### a) Gecikmeli frenleme

Genellikle sistemin yavaş ve kaydırılarak durması gereken yerlerde tercih edilen bağlantı şeklidir. Vinç yürütme motorlarındaki sarsıntıyı önlemek için gecikmeli bağlantı şekli kullanılır. Frenler fabrika çıkışında gecikmeli bağlantıya uygun ayarlanır.

### b) Ani frenleme

Genellikle sistemin enerjisi kesildiği anda ani olarak durdurulması gereken sistemlerde kullanılan bağlantı şeklidir. Vinç kaldırma sistemleri, asansör motorlarında kullanılan bağlantı şeklidir.

## d) Shock voltage supply transformer

Brakes which consist of high power and torques take long time to get in electromagnetic field. Shock voltage supply transformers with time relay are aiming to overcome spring pressure delaying for brakes. Also this transformers provide to open system suddenly by feeding double(48V DC) voltage in a short time and preventing to frictional losses occurring in delayed opening.

## Connection Types

### a) Delayed Braking

Generally this type of connection uses in slow and sliding brake intended systems. Delayed connection type using to prevent shock loadings in crane driving systems. Brakes are setting up to delayed connection if any other types are not specified by customer

### b) Sudden Braking

This type of connections are mostly used in systems when short braking times are needed. The braking torque will be produced as soon as the current fails. These brakes are mostly used in hoisting of lifting units and elevators.

## d) Trafos mit Schock-Spannung

Diese Transformatoren werden bei großen Bremsen mit hohen Momenten verwendet. Da die großen Bremsen eine lange Zeit braucht, um die erforderliche magnetische Feld zu erzeugen, wird an der Bremse kurz 48V Gleichstromspannung angelegt, um die Zeit zur Bildung von magnetischem Feld zu kürzen. Dies ermöglicht kürzere Reibungszeiten beim Start.

## Schaltungsarten:

### a) Verspätetes Bremsen

Diese Schaltung wird benutzt, wenn ein langsames und gleitendes Bremsen erforderlich ist. Am meisten wird es bei Fahrtriebemotoren von Aufzügen verwendet. Wenn keine Angabe bei der Bestellung gegeben wird, werden die Bremsen mit verspäteter Schaltung geliefert.

### b) Schnelles Bremsen:

Allgemein verwendet man diese Schaltung bei Bedarf an plötzlichen Bremsen in dem Augenblick, in dem das System keine Energie mehr erhält. Diese Schaltungsart wird meist bei Kräne und Motoren von Aufzüge verwendet.

**Gecikmeli Frenleme / Delayed Running Brake / Verspätete Bremsung**  
(230V AC - 98V DC)

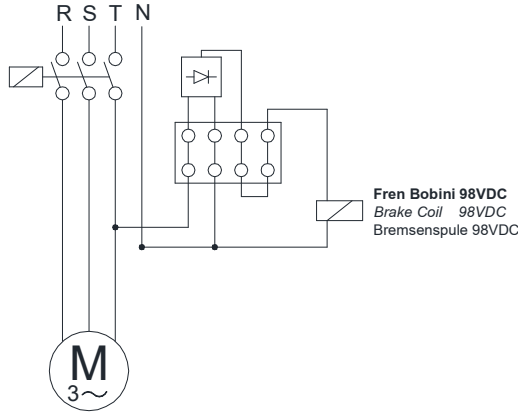

**Ani Frenleme / Sudden Brake / Plötzliche Bremsung**  
(230V AC-98V DC)

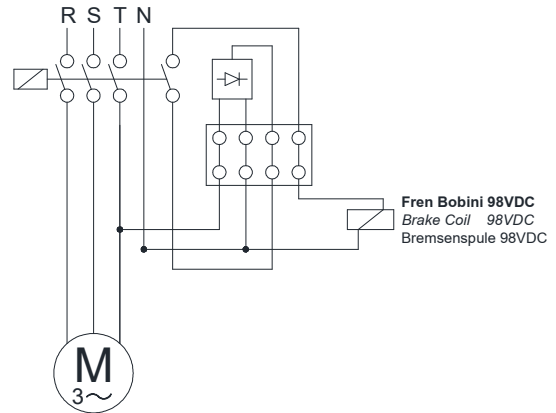

**Gecikmeli Frenleme / Delayed Running Brake / Verspätete Bremsung**  
(230V AC - 24V DC)

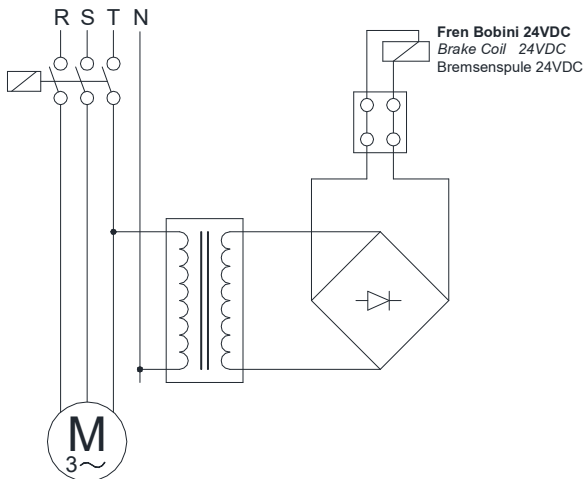

**Ani Frenleme / Sudden Brake / Plötzliche Bremsung**  
(230V AC - 24V DC)

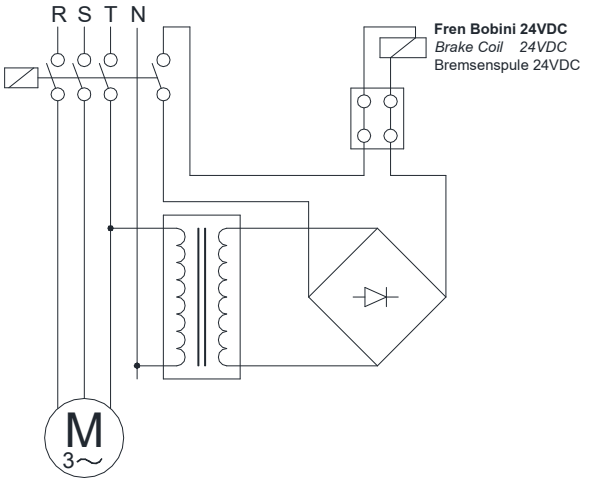



# Genel Bilgiler

## General Information

### Einführung



#### Fren Seçimi:

Doğru bir fren seçimi için aşağıdaki parametreler bilinmelidir.

- $I_{tot}$  [kg.m<sup>2</sup>] : Motor miline indirgenmiş toplam atalet momenti
- $n_0$  [d/dak] : Maksimum motor devir sayısı
- $t_f$  [s] : İstenilen en uzun frenleme zamanı
- $c_t$  : Anahtarın devreye girme zamanı katsayısı (ortalama 0,995).
- $M_L$  [Nm] : Sistemin statik tork ihtiyacı.
- $C_s$  : Emniyet katsayısı ( $C_s \geq 2$  olmalı)

Gerekli fren momenti aşağıdaki şekilde hesaplanır:

a)  $M_L$  Statik yük torku, motor dönüş yönünde (motorun dönüşüne yardımcı olarak, yükün indirilmesi veya hızlandırıcı sabit yük momenti hali):

$$M_{fc} = \frac{(2\pi \times n_0 \div 60) \times I_{tot}}{t_f \times c_t} + M_L$$

b)  $M_L$  Statik yük torku, motor aksi dönüş yönünde (motorun dönüşüne engel olarak, yükün yukarı kaldırılması veya frenleyici sabit yük/direnç momenti hali):

$$M_{fc} = \frac{(2\pi \times n_0 \div 60) \times I_{tot}}{t_f \times c_t} - M_L$$

Yukarıda bulunan sonuç  $C_s$  katsayısı ile çarpılarak ( $C_s \geq 2$ ), fren momenti seçilir;

$$M_f = M_{fc} \times C_s$$

#### Yaklaşım Yolu ile Fren Seçimi:

Eğer yalnızca motorun gücü ve en yüksek devri biliniyor ise :

W [Watt]: Motorun nominal gücü

$$M_f = \frac{W}{\frac{2\pi \times n_0}{60}} \times C_s \quad (C_s \geq 2)$$

#### Brake Selection:

To select a brake correctly the following data are necessary;

- $I_{tot}$  [kg . m<sup>2</sup>] : The total inertia of rotating parts reduced at the motor shaft
- $n_0$  [rpm] : Maximum motor speed.
- $t_f$  [s] : The maximum admitted time of the braking.
- $c_t$  : Coefficient of switch on time (average 0,995).
- $M_L$  [Nm] : Required static torque of system.
- $C_s$  : Safety coefficient ( $C_s \geq 2$ )

The necessary braking torque calculates below;

a) The static load torque  $M_L$ , same direction of motor rotation (Descent of a load or steady resisting torque which favours the rotation of the motor)

$$M_{fc} = \frac{(2\pi \times n_0 \div 60) \times I_{tot}}{t_f \times c_t} + M_L$$

b) The static load torque  $M_L$ , opposes the rotation of the motor (Lifting of a load or steady resisting torque which opposes the rotation of the motor)

$$M_{fc} = \frac{(2\pi \times n_0 \div 60) \times I_{tot}}{t_f \times c_t} - M_L$$

The necessary braking torque will result from the following equation using  $C_s$  ( $C_s \geq 2$ );

$$M_f = M_{fc} \times C_s$$

#### Approximated Brake Selection

Its only the motor power and its maximum speed are known:

W [Watt]: Motor Nominal Power

$$M_f = \frac{W}{\frac{2\pi \times n_0}{60}} \times C_s \quad (C_s \geq 2)$$

#### Bremswahl:

Um die richtige Bremse auszuwählen, braucht man unten aufgelistete Variablen;

- $I_{tot}$  [kg . m<sup>2</sup>] : Die Gesamtträgheit der rotierenden Teile (siehe Anwendungsbeispiele)
- $n_0$  [U/min] : Die höchste Drehzahl des Motors
- $t_f$  [s] : Die längste zulässige Bremszeit
- $c_t$  : Reduktionskoeffizient der Tätigkeitszeit (gemittelt 0,995).
- $M_L$  [Nm] : Vom system benötigtes, statisches Drehmoment.
- $C_s$  : Sicherheitskoeffizient ( $C_s \geq 2$ )

Die benötigte Bremskraft wird wie folgt berechnet:

a) konstantes Belastungsmoment  $M_L$ , das die Motordrehung fördert (konstante Erhöhung der Motorgeschwindigkeit oder Herunterlassen der Last)

$$M_{fc} = \frac{(2\pi \times n_0 \div 60) \times I_{tot}}{t_f \times c_t} + M_L$$

b) konstantes Belastungsmoment  $M_L$ , das sich entgegen der Motordrehung widersetzt (konstante Verminderung der Motorgeschwindigkeit oder Aufheben der Last)

$$M_{fc} = \frac{(2\pi \times n_0 \div 60) \times I_{tot}}{t_f \times c_t} - M_L$$

Wenn die Bremskraft mit dem Sicherheitskoeffizient  $C_s$  ( $C_s \geq 2$ ) multipliziert wird, erhält man die erforderliche Bremskraft;

$$M_f = M_{fc} \times C_s$$

#### Abschätzung zur Bremswahl

Wenn man nur die Motorleistung und die höchste Drehzahl kennt, kann die Bremskraft mit der folgenden Formel annähernd berechnet werden: W [Watt] : Nennleistung des Motors

$$M_f = \frac{W}{\frac{2\pi \times n_0}{60}} \times C_s \quad (C_s \geq 2)$$

#### Standart Frenler / Standard Brakes / Standart Bremsen

Fren statik momenti [Nm] Brake Static Torque [Nm] Statische Bremskraft [Nm]	4,5	8	12	16	35	60	80	150	200
Fren Dinamik Momenti [Nm] Brake Dynamic Torque [Nm] Dynamische Bremskraft [Nm]	3,6	6,4	9,6	12,8	28	48	64	120	160
Maksimum Motor Hızı [d/dak] Maximum Motor Speed [rpm] Maximale Motordrehzahl [U/min]	3000	3000	3000	3000	3000	3000	3000	1500	1500
Giriş Gücü [W] Input Power [W] Antriebsleistung [W]	15	20	25	30	45	50	55	60	65

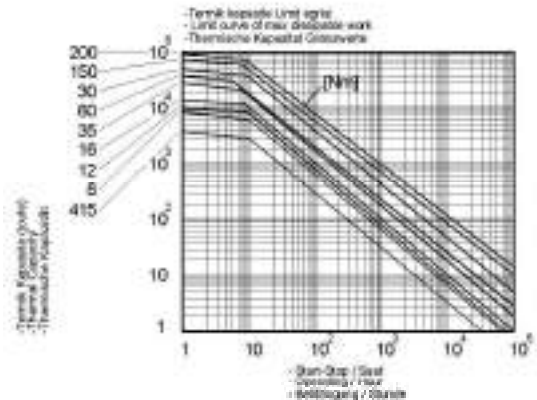



# Genel Bilgiler

## General Information

### Einführung



#### Frenin Termik Kapasitesi

Yukarıdaki seçime ek olarak frenin termik kapasitesinin kontrol edilmesi gerekir. L (joule) olarak gerekli soğutma işi aşağıdaki formüller ile hesaplanır ve "Termik kapasite limit eğrisi" kullanılarak eğrinin altında kalıp kalmadığı kontrol edilir.

a)  $M_L$  Statik yük torku motor dönüş yönünde (motorun dönüşüne yardımcı olarak, yükün indirilmesi hali)

$$L = \frac{I_{tot} \times (2 \pi \times n_0 \div 60)^2}{2} \times \left( \frac{M_f}{M_f - M_L} \right)$$

b)  $M_L$  Statik yük torku motor aksi dönüş yönünde (motorun dönüşüne engel olarak, yükün kaldırılması hali):

$$L = \frac{I_{tot} \times (2 \pi \times n_0 \div 60)^2}{2} \times \frac{M_f}{M_f + M_L}$$

c)  $M_L$  Statik yük torku sabit, motor yönünde veya aksi yönde (kaldırma ve indirme harici hızlandırıcı veya frenleyici sabit bir yük momenti hali).

$$L = \frac{I_{tot} \times (2 \pi \times n_0 \div 60)^2}{2}$$

#### Fren Hava Boşluğunun Ayarı:

Frenin sürekli aynı performansın alınabilmesi için, fren balatasının aşınmasına bağlı olarak, fren hava boşluğu belirli zaman aralıklarında yeniden ayarlanmalıdır. Fren hava boşluğu ayar zaman aralığı ve ayarın yapılması için firmamıza danışınız.

#### Fren Seçim Örneği:

İstenilen en uzun frenleme zamanı: 0,5 sn.

Motor devri: 1400 d/dak

Motorla indirgenmiş toplam atalet momenti:

0,08 kgm<sup>2</sup>

Gerekli çalışma momenti: 50 Nm

Yük Durumu: Yük motor dönüş yönü ile aynı

(Vinçten yük indirilmesi: Saatte dur-kalk sayısı:30)

$$M_{fc} = \frac{(2 \pi \times 1400 \div 60)}{0,5 \times 0,995} + 50 = 73,6 \text{ Nm}$$

$$M_f = 73,6 \times 2 = 147,2 \text{ Nm}$$

Standart frenler tablosundan 150 Nm lik fren seçilebilir.

Gerekli termik kapasite;

$$L = \frac{0,08 \times (2 \pi \times 1400 \div 60)^2}{2} \times \left( \frac{147,2}{147,2 - 50} \right)$$

=1302,0<18000 Joule (150 Nm eğrisinden)

150 Nm lik fren uygun görülüyor.

#### The Thermal Capacity of Brake

The thermal capacity of the brake must also be checked after the above mentioned calculations. The heat dissipation energy L (joule) can be calculated from the following equation and must be checked if the result is under the limit curve shown on "Limit curve of may dissipable work".

a) The static load torque  $M_L$ , favours the rotation of the motor (Descent of a load which favours the rotation of the motor)

$$L = \frac{I_{tot} \times (2 \pi \times n_0 \div 60)^2}{2} \times \left( \frac{M_f}{M_f - M_L} \right)$$

b) The static load torque  $M_L$ , opposes the rotation of the motor (Lifting of a load which opposes the rotation of the motor)

$$L = \frac{I_{tot} \times (2 \pi \times n_0 \div 60)^2}{2} \times \frac{M_f}{M_f + M_L}$$

c) The static load torque  $M_L$ , is constant and opposes or favours the rotation of the motor (except lifting of a load)

$$L = \frac{I_{tot} \times (2 \pi \times n_0 \div 60)^2}{2}$$

#### Adjustment of the air-gap:

In order to obtain the same performance from the brake during its lifetime, the air-gap of the brake must be re-adjusted after a limited time of operation. For the air-gap and the time interval of the adjustment please contact us.

#### Selection Example:

The maximum admitted time for braking 0,5 s

Motor speed: 1400 rpm

Total inertia reduced at motor shaft: 0,08 kgm<sup>2</sup>

Required operating torque: 50 Nm

Nature of load: Load direction is same as motor direction (Unloading process: Start-stop time

per hour :30)

$$M_{fc} = \frac{(2 \pi \times 1400 \div 60)}{0,5 \times 0,995} + 50 = 73,6 \text{ Nm}$$

$$M_f = 73,6 \times 2 = 147,2 \text{ Nm}$$

From the brake selection table a standard brake of 150 Nm is selected.

Necessary thermal capacity

$$L = \frac{0,08 \times (2 \pi \times 1400 \div 60)^2}{2} \times \left( \frac{147,2}{147,2 - 50} \right)$$

=1302,0<18000 Joule (from 150 Nm curve)

The selected brake with 150 Nm is suitable.

#### Thermische Kapazität der Bremsen

Nach den oben genannten Berechnungen muss die Thermische Kapazität überprüft werden. Die Wärme, d.h. die gebrauchte Energie L, werden mit den folgenden Formeln berechnet. Die gerechnete Kapazitätswerte sollen unter dem Grenzkurve "Thermische Kapazität Grenzwerte" der gewählten Bremse liegen.

a) Konstantes Belastungsmoment  $M_L$ , das die Motordrehung fördert (Herunterlassen der Last)

$$L = \frac{I_{tot} \times (2 \pi \times n_0 \div 60)^2}{2} \times \left( \frac{M_f}{M_f - M_L} \right)$$

b) Konstantes Belastungsmoment  $M_L$ , das sich entgegen der Motordrehung widersetzt (Aufheben der Last)

$$L = \frac{I_{tot} \times (2 \pi \times n_0 \div 60)^2}{2} \times \frac{M_f}{M_f + M_L}$$

c) Konstantes Belastungsmoment  $M_L$ , das sich gegen der Motorbewegung widersetzt oder die Motorrotation fördert (Konstante Verminderung oder Erhöhung der Motorgeschwindigkeit, kein Herunterlassen oder Aufheben der Last)

$$L = \frac{I_{tot} \times (2 \pi \times n_0 \div 60)^2}{2}$$

#### Einstellung des Luftspaltes:

Um eine immer konstant bleibende Bremsfähigkeit zu erhalten, muss das Luftspalt nach einer bestimmten Arbeitszeit neu eingestellt werden. Für die Bestimmung des Luftspaltes und die Einstellzeiten bitten wir Sie um Rückfrage.

#### Beispiel für eine Auswahl:

Die höchste zulässige Bremszeit: 0,5 s

Motordrehzahl: 1400 U/min

Gesamträgheit der rotierenden Teile: 0,08 kgm<sup>2</sup>

Das auf das System wirkende Drehmoment:

50 Nm

Belastungsart: Drehmoment, das die Motor-

rotation fördert (Herunterlassen der Last)

Betätigungen pro Stunde:30

$$M_{fc} = \frac{(2 \pi \times 1400 \div 60)}{0,5 \times 0,995} + 50 = 73,6 \text{ Nm}$$

$$M_f = 73,6 \times 2 = 147,2 \text{ Nm}$$

Eine Bremse von 150 Nm kann man auswählen.

Die thermische Kapazität;

$$L = \frac{0,08 \times (2 \pi \times 1400 \div 60)^2}{2} \times \left( \frac{147,2}{147,2 - 50} \right)$$

=1302,0<18000 Joule (von 150 Nm Kurve) Die

ausgewählte 150 Nm Bremse ist ausreichend.



# Güç ve Devir Tabloları

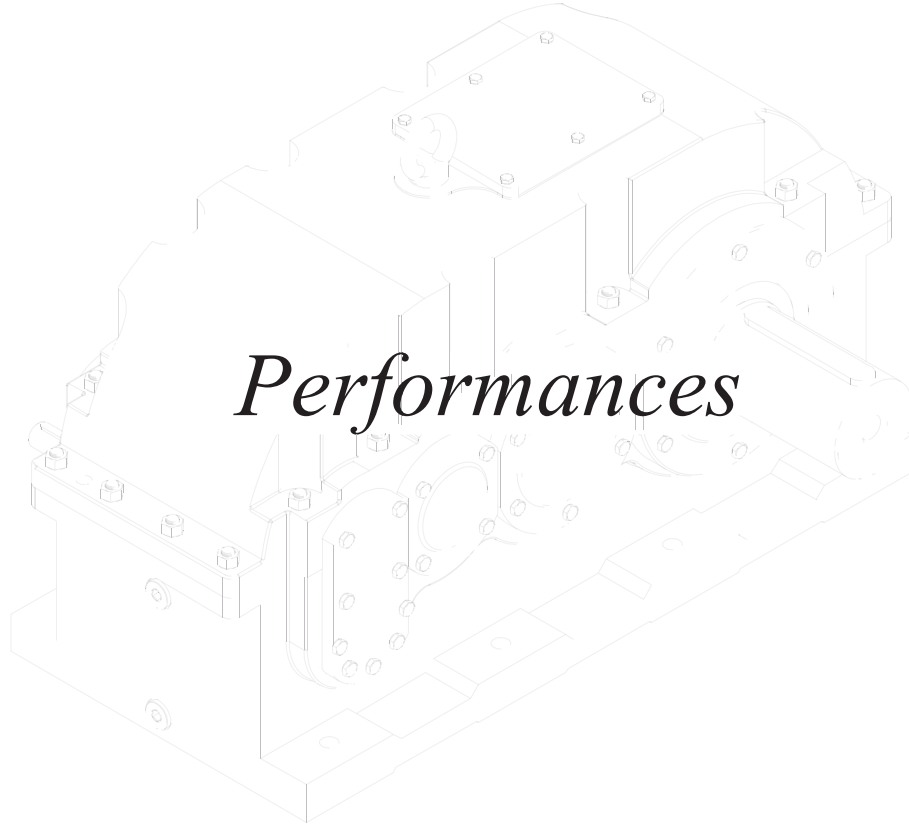

## Leistungs- und Drehzahltabellen



## Y Serisi Güç Devir Sayfaları

### Y Series Performance Tables

#### Y Serie Leistung und Drehzahlübersicht



Anma Momenti <i>Nominal Torques</i>  Nenn- drehmomente  Ma max.[Nm] n1=1450	Çevrim Oranı  Überset- zung	Çıkış Devri  <i>Output Speeds</i>  Abtriebswelle Drehzahlen  n2 [r.p.m] n1=1450	Tipi  <i>Type</i>  Typ	Nominal Güç Pe [kW] ( Servis Faktörü fs = 1 için )  <i>Nominal Power Pe [kW] ( For Service Factor fs = 1 )</i>  Nominal Leistung Pe [kW] ( Bei Betriebsfaktor fs = 1 )					Güv. Rad. Yük(Çık.)  <i>Per. Over. Loads (Out)</i>  Zul. Querkräfte (Ausgang)  Fqgv [N] n1=1450	Güv. Rad. Yük(Gir.)  <i>Per. Over. Loads(In)</i>  Zul Querkräfte (Eingang)  Fqgv [N] n1=1450	Ağırlık  <i>Weight</i>  Gewicht  ~ [kg]	Ölçü Sayfası  <i>Dim. Page</i>  Maße Seite	Fiyat Kodu  <i>Price Ref.</i>  Preis No
				n1=1450	n1=950	n1=725	n1=475	n1=360					
2255 2123 1950 1719 1979 1737 1637 1469 1285 1583	2,13 2,62 2,92 3,27 3,54 3,92 4,36 4,58 5,09 6,27	680 554 497 443 410 370 332 316 285 231	YRM1125	160 123 102 80 85 67 57 49 38 38	105 80 67 51 55 44 41 32 24 24	80 60 49 39 41 33 28 23 18 19	53 39 33 25 26 21 18 15 12 7,7	34 25 21 16 17 14 11 10 7,5 5,0	9581 10240 10610 11014 10848 11203 11593 11453 11833 12248	4425 4267 4179 4082 3606 3496 3375 3026 2886 2252	72	60	YR01
3900 3900 3900 3900 3900 3900 3163 3512 2947	1,86 2,81 3,07 3,36 3,69 4,08 4,55 5,33 5,42 6,00	781 516 473 432 393 355 319 272 268 242	YRM1160	318 211 194 176 160 145 130 90 98 75	209 138 127 115 105 95 85 58 63 46	159 105 97 88 80 73 64 44 48 34	104 69 63 58 53 48 42 27 31 21	68 45 41 38 34 31 27 19 21 14	9470 10855 11160 11488 11844 12233 12661 13703 12752 13165	4549 4053 3935 3809 3673 3526 3365 3526 2398 2196	110	61	YR02
6100 6100 6100 6100 6100 6100 6100 6100 6100 6100	1,41 2,67 2,93 3,23 3,58 3,92 4,33 4,85 5,33 6,08	1030 544 495 449 405 370 544 299 272 238	YRM1200	657 347 316 287 259 236 214 191 174 152	430 227 207 188 169 155 140 125 114 100	328 173 158 143 129 118 107 95 87 76	215 114 104 94 85 77 70 63 57 50	140 74 67 61 55 50 46 41 37 32	23710 29256 30120 31055 32073 32535 29686 32570 33547 34480	4399 3881 3755 3621 3477 2868 2701 - - -	215	62	YR03
1800 1800 1800 1647 1604 1514 1454 1363 1405 1337	7,79 8,65 9,61 10,51 11,75 13,05 14,91 16,66 18,71 20,01	186 168 151 138 123 111 97 87 78 72	YRM2195	35 32 28 24 21 18 15 12 11 10	23 21 19 15 14 11 9,7 7,6 7,2 6,7	18 16 14 12 10 8,3 7,3 5,8 5,5 5,1	11 10 9,3 7,3 6,7 5,4 4,8 3,8 3,5 3,2	7,5 6,7 6,1 4,7 4,2 3,5 3,1 2,5 2,3 2,1	9202 9068 9159 9038 9112 8960 8458 8283 8654 9636	3409 3161 3051 3075 2949 2973 2657 2726 2691 3150	73	63	YR04
3300 3300 3300 3300 3300 3281 3300 3274 3018 2579	7,06 8,57 9,52 10,51 11,75 13,05 14,24 15,91 17,70 20,86	205 169 152 138 123 111 102 91 82 69	YRM2240 YRE2240	72 59 53 48 42 38 35 31 26 19	47 39 35 31 28 24 22 19 18 12	36 29 26 24 21 19 17 15 14 9,0	23 19 17 16 14 12 11 9,5 8,7 5,9	15 13 11 10 9,0 7,7 7,2 6,2 5,6 3,7	14537 15035 15296 15349 15611 15621 14809 14599 14774 15834	3571 3379 3264 3294 3163 3193 2769 2803 2639 3140	126 150	64 86	YR05 YE05
5200 5200 5200 5085 5108	7,91 8,65 9,61 10,48 11,71	183 168 151 138 124	YRM2275 YRE2275	100 91 82 74 66	65 60 54 49 42	50 46 41 37 32	33 30 27 23 21	21 19 17 15 13	22842 23839 24448 24815 25480	8395 8533 8424 8451 8327	205	65 86	YR06 YE06





## Y Serisi Güç Devir Sayfaları

### Y Series Performance Tables

### Y Serie Leistung und Drehzahlübersicht



Anma Momenti <i>Nominal Torques</i>  Nenn-drehmomente  Ma max.[Nm] n1=1450	Çevrim Oranı <i>Ratio</i>  Übersetzung	Çıkış Devri <i>Output Speeds</i>  Abtriebswelle Drehzahlen  n2 [r.p.m] n1=1450	Tipi <i>Type</i>  Typ	Termik Güç Pt [kW] ( Servis Faktörü fs = 1 için )  <i>Thermal Power Pt [kW] ( For Service Factor fs = 1 )</i>  Wärme-Grenzleistungen Pt [kW] ( Bei Betriebsfaktor fs = 1 )					Güv. Rad. Yük(Çık.) <i>Per. Over. Loads (Out)</i>  Zul. Querkräfte (Ausgang)  Fqgv [N] n1=1450	Güv. Rad. Yük(Gir.) <i>Per. Over. Loads(In)</i>  Zul Querkräfte (Eingang)  Fqgv [N] n1=1450	Ağırlık <i>Weight</i>  Gewicht  ~ [kg]	Ölçü Sayfası <i>Dim. Page</i>  Maße Seite	Fiyat Kodu <i>Price Ref.</i>  Preis No
				n1=1450	n1=950	n1=725	n1=475	n1=360					
2255 2123 1950 1719 1979 1737 1637 1469 1285 1583	2,13 2,62 2,92 3,27 3,54 3,92 4,36 4,58 5,09 6,27	680 554 497 443 410 370 332 316 285 231	YRM1125	27 25 24 22 21 23 21 22 21 20	25 23 22 21 20 21 20 19 19 18	24 22 21 20 19 20 19 19 18 17	22 20 19 18 17 18 17 17 17 16	21 19 18 18 19 18 17 17 17 16	9581 10240 10610 11014 10848 11203 11593 11453 11833 12248	4425 4267 4179 4082 3606 3496 3375 3026 2886 2252	72	60	YR01
3900 3900 3900 3900 3900 3900 3900 3163 3512 2947	1,86 2,81 3,07 3,36 3,69 4,08 4,55 5,33 5,42 6,00	781 516 473 432 393 355 319 272 268 242	YRM1160	50 43 41 39 37 35 33 35 34 32	46 39 37 36 34 32 31 32 31 30 29	43 37 35 34 32 31 29 27 27 26 26	39 34 32 31 30 29 27 27 26 25	37 32 31 30 29 27 26 26 26 25	9470 10855 11160 11488 11844 12233 12661 13703 12752 13165	4549 4053 3935 3809 3673 3526 3365 3526 2398 2196	110	61	YR02
6100 6100 6100 6100 6100 6100 6100 6100 6100 6100	1,41 2,67 2,93 3,23 3,58 3,92 4,33 4,85 5,33 6,08	1030 544 495 449 405 370 344 299 272 238	YRM1200	99 71 68 64 61 63 59 60 57 56	91 65 63 60 57 58 55 56 53 53 52	85 62 59 57 54 55 52 53 50 49	77 57 54 52 50 48 46 46 44 46	71 54 51 49 47 48 46 46 44 44	23710 29256 30120 31055 32073 32535 29686 32570 33547 34480	4399 3881 3755 3621 3477 2868 2701 - - -	215	62	YR03
1800 1800 1800 1647 1604 1514 1454 1363 1405 1337	7,79 8,65 9,61 10,51 11,75 13,05 14,91 16,66 18,71 20,01	186 168 151 138 123 111 97 87 78 72	YRM2195	14 14 13 13 13 12 12 12 12 11	14 14 13 13 12 12 12 11 11 11	13 13 12 12 11 11 11 11 10 11	12 12 12 11 11 11 11 10 10 11	12 12 12 11 11 11 11 10 10 10	9202 9068 9159 9038 9112 8960 8458 8283 8654 9636	3409 3161 3051 3075 2949 2973 2657 2726 2691 3150	73	63	YR04
3300 3300 3300 3300 3281 3300 3274 3018 2579	7,06 8,57 9,52 10,51 11,75 13,05 14,24 15,91 17,70 20,86	205 169 152 138 123 111 102 91 82 69	YRM2240 YRE2240	26 24 22 22 21 21 21 20 20 20	24 22 21 21 20 20 20 19 19 19	22 21 20 20 19 19 19 18 18 18	21 20 19 19 18 18 18 17 17 17	20 19 19 18 18 18 17 17 17	14537 15035 15296 15349 15611 15621 14809 14599 14774 15834	3571 3379 3264 3294 3163 3193 2769 2803 2639 3140	126 150	64 86	YR05 YE05
5200 5200 5200 5085 5108	7,91 8,65 9,61 10,48 11,71	183 168 151 138 124	YRM2275 YRE2275	33 29 28 28 26	30 28 27 27 26	28 27 26 25 25	26 25 24 24 23	25 24 23 23 22	22842 23839 24448 24815 25480	8395 8533 8424 8451 8327	205	65 86	YR06 YE06



# Y Serisi Güç Devir Sayfaları

## Y Series Performance Tables

### Y Serie Leistung und Drehzahlübersicht



Anma Momenti <i>Nominal Torques</i>  Nenn- drehmomente  Ma max.[Nm] n1=1450	Çevrim Oranı  Überset- zung	Çıkış Devri  <i>Output Speeds</i>  Abtriebswelle Drehzahlen  n2 [r.p.m] n1=1450	Tipi  <i>Type</i>  Typ	Nominal Güç Pe [kW] ( Servis Faktörü fs = 1 için )  <i>Nominal Power Pe [kW] ( For Service Factor fs = 1 )</i>  Nominal Leistung Pe [kW] ( Bei Betriebsfaktor fs = 1 )					Güv. Rad. Yük(Çık.)  <i>Per. Over. Loads (Out)</i>  Zul. Querkräfte (Ausgang)  Fqgv [N] n1=1450	Güv. Rad. Yük(GİR.)  <i>Per. Over. Loads(In)</i>  Zul Querkräfte (Eingang)  Fqgv [N] n1=1450	Ağırlık  <i>Weight</i>  Gewicht  ~ [kg]	Ölçü Sayfası  <i>Dim. Page</i>  Maße Seite	Fiyat Kodu  <i>Price Ref.</i>  Preis No
				n1=1450	n1=950	n1=725	n1=475	n1=360					
4802	12,82	113	YRM2275	57	36	27	18	12	25833	8354	140	65	YR06
4766	13,71	106	YRE2275	53	35	26	17	11	25541	8010		86	YE06
4195	15,08	96		42	27	21	14	9,3	25835	8041			
4355	16,78	86		39	25	19	12	8,0	26438	7890			
4321	18,13	80		36	23	17	12	7,5	26519	7583			
3820	20,05	72		29	19	15	9,5	6,2	26724	7614			
7260	8,17	178	YRM2305	134	86	66	43	27	31073	4297	220	66	YR07
7248	9,16	158	YRE2305	120	77	58	38	24	31951	4144	250	87	YE07
6707	10,87	133		93	60	46	30	19	31527	3407			
6663	12,03	121		84	56	43	27	17	32249	3223			
6737	13,40	108		76	49	36	23	15	33034	3014			
6839	14,77	98		71	45	35	22	14	33375	3062			
6153	16,36	89		57	36	28	17	11	33638	3111			
5937	17,19	84		52	33	26	17	11	32868	2542			
6130	19,17	76		49	28	23	15	10	33019	2599			
10500	7,43	195	YRM2340	215	141	108	71	46	42694	3031	344	67	YR08
10500	8,21	177	YRE2340	194	127	97	64	41	43825	2847	370	87	YE08
10500	9,11	159		175	115	88	57	37	45035	2642			
10500	10,18	142		156	102	78	51	33	46384	2410			
10500	10,87	133		146	96	73	48	31	45788	1244			
9867	12,34	118		122	79	60	39	26	48151	2534			
9833	13,17	110		113	73	56	37	23	47416	1394			
9852	14,54	100		103	66	51	33	21	48563	1114			
9037	15,99	91		86	56	43	27	17	48838	1547			
8983	17,65	82		77	51	37	24	16	49983	1261			
8985	19,62	74		70	44	32	22	14	51234	939			
7975	21,67	67		56	37	27	18	11	51856	1008			
15000	8,09	179	YRM2385	281	184	141	92	59	54788	4219	486	68	YR09
15000	8,82	164	YRE2385	259	170	129	85	55	56019	4053	502	88	YE09
14612	10,52	138		211	136	103	67	43	58464	3935			
14779	11,57	125		195	124	95	61	39	59916	3730			
14130	12,66	115		170	111	84	54	35	61062	3796			
14096	14,00	104		153	99	75	48	32	62732	3566			
13919	15,58	93		135	87	66	43	27	64539	3307			
11828	17,01	85		106	70	52	34	22	65107	3704			
11976	18,94	77		96	62	48	30	20	66949	3439			
19000	7,70	188	YRM2430	375	245	187	123	80	66644	9353	485	69	YR10
19000	8,45	172	YRE2430	342	224	171	112	73	68310	9160		88	YE10
19000	9,21	157		314	205	157	103	67	69660	9233			
19000	10,15	143		284	186	142	93	61	71499	9020			
19000	11,12	130		260	170	130	85	55	72913	9096			
19000	12,32	118		235	154	117	77	50	74952	8856			
19000	13,56	107		214	140	107	70	45	76427	8935			
19000	15,12	96		192	126	96	63	41	78678	8663			
17815	16,73	87		162	105	80	52	34	80284	8744			
17831	18,67	78		144	93	71	46	29	80744	7462			
15592	20,79	70		114	74	55	37	24	82140	7559			



## Y Serisi Güç Devir Sayfaları Y Series Performance Tables Y Serie Leistung und Drehzahlübersicht



Anma Momenti <i>Nominal Torques</i>  Nenn- drehmomente  Ma max.[Nm] n1=1450	Çevrim Oranı  Überset- zung	Çıkış Devri  Output Speeds  Abtriebswelle Drehzahlen  n2 [r.p.m] n1=1450	Tipi  Type  Typ	Termik Güç Pt [kW] ( Servis Faktörü fs = 1 için )  Thermal Power Pt [kW] ( For Service Factor fs = 1 )  Wärme-Grenzleistungen Pt [kW] ( Bei Betriebsfaktor fs = 1 )					Güv. Rad. Yük(Çık.)  Per. Over. Loads (Out)  Zul. Querkräfte (Ausgang)  Fqgv [N] n1=1450	Güv. Rad. Yük(Gir.)  Per. Over. Loads(In)  Zul Querkräfte (Eingang)  Fqgv [N] n1=1450	Ağırlık  Weight  Gewicht  ~ [kg]	Ölçü Sayfası  Dim. Page  Maße Seite	Fiyat Kodu  Price Ref.  Preis No
				n1=1450	n1=950	n1=725	n1=475	n1=360					
4802	12,82	113	YRM2275	26	25	24	23	22	25833	8354	140	65 86	YR06 YE06
4766	13,71	106	YRE2275	27	26	24	23	22	25541	8010			
4195	15,08	96		26	25	24	23	22	25835	8041			
4355	16,78	86		25	24	23	22	21	26438	7890			
4321	18,13	80		25	24	23	22	21	26519	7583			
3820	20,05	72		25	23	23	22	21	26724	7614			
7260	8,17	178	YRM2305	39	37	35	33	32	31073	4297	220	66 87	YR07 YE07
7248	9,16	158	YRE2305	36	36	34	32	31	31951	4144			
6707	10,87	133		38	36	34	32	31	31527	3407			
6663	12,03	121		36	35	33	31	30	32249	3223			
6737	13,40	108		34	34	32	30	29	33034	3014			
6839	14,77	98		34	33	32	30	29	33375	3062			
6153	16,36	89		34	32	31	29	28	33638	3111			
5937	17,19	84		35	33	31	30	29	32868	2542			
6130	19,17	76		35	32	31	29	28	33019	2599			
10500	7,43	195	YRM2340	57	53	50	46	44	42694	3031	344	67 87	YR08 YE08
10500	8,21	177	YRE2340	54	51	48	45	43	43825	2847			
10500	9,11	159		51	49	47	43	42	45035	2642			
10500	10,18	142		48	47	45	42	40	46384	2410			
10500	10,87	133		51	48	46	43	41	45788	1244			
9867	12,34	118		47	45	43	41	39	48151	2534			
9833	13,17	110		50	47	44	42	40	47416	1394			
9852	14,54	100		48	45	43	41	39	48563	1114			
9037	15,99	91		50	46	44	41	40	48838	1547			
8983	17,65	82		47	45	43	40	39	49983	1261			
8985	19,62	74		45	43	41	39	38	51234	939			
7975	21,67	67		44	42	41	38	37	51856	1008			
15000	8,09	179	YRM2385	72	65	62	57	54	54788	4219	486	68 88	YR09 YE09
15000	8,82	164	YRE2385	69	63	60	55	53	56019	4053			
14612	10,52	138		65	60	57	53	51	58464	3935			
14779	11,57	125		62	58	55	51	49	59916	3730			
14130	12,66	115		61	57	54	51	49	61062	3796			
14096	14,00	104		58	55	53	49	47	62732	3566			
13919	15,58	93		55	53	51	48	46	64539	3307			
11828	17,01	85		57	53	51	47	46	65107	3704			
11976	18,94	77		54	51	49	46	45	66949	3439			
19000	7,70	188	YRM2430	91	84	80	73	69	66644	9353	485	69 88	YR10 YE10
19000	8,45	172	YRE2430	87	82	77	71	68	68310	9160			
19000	9,21	157		86	80	76	70	67	69660	9233			
19000	10,15	143		82	77	73	68	65	71499	9020			
19000	11,12	130		81	76	72	67	64	72913	9096			
19000	12,32	118		77	73	69	65	62	74952	8856			
19000	13,56	107		76	71	68	63	61	76427	8935			
19000	15,12	96		72	69	66	61	59	78678	8663			
17815	16,73	87		71	67	64	60	58	80284	8744			
17831	18,67	78		73	67	64	60	58	80744	7462			
15592	20,79	70		72	66	63	59	57	82140	7559			



## Y Serisi Güç Devir Sayfaları

### Y Series Performance Tables

### Y Serie Leistung und Drehzahlübersicht



Anma Momenti <i>Nominal Torques</i>  Nenn- drehmomente  Ma max.[Nm] n1=1450	Çevrim Oranı  Überset- zung	Çıkış Devri <i>Output Speeds</i>  Abtriebswelle Drehzahlen  n2 [r.p.m] n1=1450	Tipi <i>Type</i>  Typ	Nominal Güç Pe [kW] ( Servis Faktörü fs = 1 için )  <i>Nominal Power Pe [kW] ( For Service Factor fs = 1 )</i>  Nominal Leistung Pe [kW] ( Bei Betriebsfaktor fs = 1 )					Güv. Rad. Yük(Çık.)  <i>Per. Over. Loads (Out)</i>  Zul. Querkräfte (Ausgang)  Fqgv [N] n1=1450	Güv. Rad. Yük(Gir.)  <i>Per. Over. Loads(In)</i>  Zul Querkräfte (Eingang)  Fqgv [N] n1=1450	Ağırlık  <i>Weight</i>  Gewicht  ~ [kg]	Ölçü Sayfası  <i>Dim. Page</i>  Maße Seite	Fiyat Kodu  <i>Price Ref.</i>  Preis No
				n1=1450	n1=950	n1=725	n1=475	n1=360					
27500	7,43	195	YRM2480	562	368	281	184	140	60000	3000	851	70	YR11
27500	7,61	190	YRE2480	548	359	274	180	136	63000	3200	919	89	YE11
27500	8,40	173		497	326	249	163	123	68000	3500			
27500	9,23	157		452	296	226	148	112	72000	4000			
27500	10,24	142		408	267	204	134	101	75000	4200			
27500	11,65	125		359	235	179	117	89	80000	6000			
27500	12,75	114		327	215	164	107	81	85000	6500			
26500	13,86	105		290	190	145	95	72	90000	9500			
26500	15,31	95		263	172	131	86	65	90000	12000			
24500	16,71	87		223	146	111	73	55	95000	12000			
24500	18,69	78		199	130	100	65	49	95000	12000			
21500	20,50	71		159	104	80	52	40	95000	12000			
37500	8,27	175	YRM2545	689	451	344	226	171	78000	15000	1070	71	YR12
37500	9,01	161	YRE2545	632	414	316	207	157	82000	16000	1343	89	YE12
35500	9,82	148		549	360	275	180	136	85000	18000			
35500	10,74	135		502	329	251	164	125	90000	20000			
33000	11,76	123		426	279	213	140	106	100000	25000			
33000	12,92	112		388	254	194	127	96	120000	25000			
29500	14,21	102		315	207	158	103	78	140000	30000			
29500	15,71	92		285	187	143	93	71	145000	32000			
25000	17,36	84		219	143	109	72	54	150000	34000			
25000	19,32	75		196	129	98	64	49	155000	35000			
5400	21,91	66	YRM3355	37	24	19	12	7,9	21009	1621	165	72	YR13
5400	24,34	60		34	22	17	11	7,3	20554	1243			
5400	26,63	54		31	20	15	10	6,6	13011	1270			
5400	29,03	50		28	19	14	9,3	6,0	19355	1346			
5400	32,24	45		26	17	13	8,4	5,4	19017	1103			
5400	35,80	41		23	15	11	7,4	4,8	17376	1150			
5131	39,19	41		20	14	9,9	6,4	4,2	17102	1369			
5117	43,80	33		18	11	8,7	5,7	3,6	19717	1523			
5147	48,94	30		16	10	8,0	5,1	3,3	21287	2037			
4741	53,83	27		13	8,7	6,7	4,3	2,8	26249	2826			
4615	61,52	24		11	7,4	5,7	3,7	2,4	29339	3066			
4627	65,79	22		11	7,1	5,4	3,5	2,3	30425	3292			
4134	72,76	20		8,7	5,7	4,4	2,9	1,8	35983	3971			
4097	81,70	18		7,6	5,0	3,9	2,6	1,6	38455	4057			
4029	90,95	16		6,7	4,4	3,3	2,2	1,4	41070	4389			
3486	101,24	14		5,2	3,5	2,7	1,7	1,1	47055	4928			



## Y Serisi Güç Devir Sayfaları

### Y Series Performance Tables

### Y Serie Leistung und Drehzahlübersicht



Anma Momenti <i>Nominal Torques</i>	Çevrim Oranı <i>Ratio</i>  Übersetzung	Çıkış Devri <i>Output Speeds</i>  Abtriebswelle Drehzahlen	Tipi <i>Type</i>  Typ	Termik Güç Pt [kW] ( Servis Faktörü fs = 1 için )  <i>Thermal Power Pt [kW] ( For Service Factor fs = 1 )</i>  Wärme-Grenzleistungen Pt [kW] ( Bei Betriebsfaktor fs = 1 )					Güv. Rad. Yük(Çık.) <i>Per. Over. Loads (Out)</i>	Güv. Rad. Yük(Gir.) <i>Per. Over. Loads(In)</i>	Ağırlık <i>Weight</i>	Ölçü Sayfası <i>Dim. Page</i>	Fiyat Kodu <i>Price Ref.</i>
									Zul. Querkräfte (Ausgang)	Zul Querkräfte (Eingang)	Gewicht	Maße Seite	Preis No
				Ma max.[Nm] n1=1450	n2 [r.p.m] n1=1450	n1=1450	n1=950	n1=725	n1=475	n1=360	Fqgv [N] n1=1450	Fqgv [N] n1=1450	~ [kg]
27500	7,43	195	YRM2480	111	104	98	90	85	60000	3000	851	70	YR11
27500	7,61	190	YRE2480	111	103	98	90	85	63000	3200	919	89	YE11
27500	8,40	173		105	100	94	87	83	68000	3500			
27500	9,23	157		104	98	92	85	81	72000	4000			
27500	10,24	142		99	94	89	82	79	75000	4200			
27500	11,65	125		98	96	91	84	80	80000	6000			
27500	12,75	114		100	96	91	84	80	85000	6500			
26500	13,86	105		99	94	89	83	79	90000	9500			
26500	15,31	95		94	91	86	80	77	90000	12000			
24500	16,71	87		93	89	85	79	76	95000	12000			
24500	18,69	78		94	88	84	79	76	95000	12000			
21500	20,50	71		94	87	83	77	74	95000	12000			
37500	8,27	175	YRM2545	153	139	131	120	113	78000	15000	1070	71	YR12
37500	9,01	161	YRE2545	146	135	127	117	110	82000	16000	1343	89	YE12
35500	9,82	148		145	132	125	114	109	85000	18000			
35500	10,74	135		138	128	121	111	106	90000	20000			
33000	11,76	123		136	125	119	109	104	100000	25000			
33000	12,92	112		129	121	115	106	101	120000	25000			
29500	14,21	102		128	118	112	104	99	140000	30000			
29500	15,71	92		121	114	108	101	97	145000	32000			
25000	17,36	84		120	111	106	99	95	150000	34000			
25000	19,32	75		113	107	102	96	92	155000	35000			
5400	21,91	66	YRM3355	22	21	20	19	18	21009	1621	165	72	YR13
5400	24,34	60		21	20	20	19	18	20554	1243			
5400	26,63	54		21	20	19	18	18	13011	1270			
5400	29,03	50		21	20	19	18	18	19355	1346			
5400	32,24	45		20	19	19	18	17	19017	1103			
5400	35,80	41		20	19	18	18	17	17376	1150			
5131	39,19	41		20	19	18	18	17	17102	1369			
5117	43,80	33		19	18	18	17	17	19717	1523			
5147	48,94	30		19	18	17	17	17	21287	2037			
4741	53,83	27		19	18	17	17	16	26249	2826			
4615	61,52	24		18	18	17	17	16	29339	3066			
4627	65,79	22		18	18	17	17	17	30425	3292			
4134	72,76	20		18	18	17	17	16	35983	3971			
4097	81,70	18		17	17	17	16	16	38455	4057			
4029	90,95	16		17	17	17	16	16	41070	4389			
3486	101,24	14		17	17	16	16	16	47055	4928			





## Y Serisi Güç Devir Sayfaları

### Y Series Performance Tables

### Y Serie Leistung und Drehzahlübersicht



Anma Momenti <i>Nominal Torques</i>  Nenn- drehmomente  Ma max.[Nm] n1=1450	Çevrim Oranı  Überset- zung	Çıkış Devri <i>Output Speeds</i>  Abtriebswelle Drehzahlen  n2 [r.p.m] n1=1450	Tipi <i>Type</i>  Typ	Nominal Güç Pe [kW] ( Servis Faktörü fs = 1 için )  <i>Nominal Power Pe [kW] ( For Service Factor fs = 1 )</i>  Nominal Leistung Pe [kW] ( Bei Betriebsfaktor fs = 1 )					Güv. Rad. Yük(Çık.)  <i>Per. Over. Loads (Out)</i>  Zul. Querkräfte (Ausgang)  Fqgv [N] n1=1450	Güv. Rad. Yük(Gir.)  <i>Per. Over. Loads(In)</i>  Zul Querkräfte (Eingang)  Fqgv [N] n1=1450	Ağırlık  <i>Weight</i>  Gewicht  ~ [kg]	Ölçü Sayfası  <i>Dim. Page</i>  Maße Seite	Fiyat Kodu  <i>Price Ref.</i>  Preis No
				n1=1450	n1=950	n1=725	n1=475	n1=360					
7852	21,78	67	YRM3395	55	36	27	18	12	23621	2993	225	73	YR14
7900	23,92	61		50	33	25	16	11	23542	2801			
7900	26,84	54		45	29	22	15	9,5	22704	2863			
7900	29,44	49		41	25	19	12	7,9	22560	2926			
7900	36,02	40		33	22	17	11	6,8	21846	2457			
7589	38,94	37		30	19	15	9,6	6,1	20793	2491			
7708	42,92	34		27	18	14	8,7	5,7	20275	2557			
7548	47,91	30		24	16	12	7,8	5,0	18818	2170			
7556	53,03	27		22	14	11	7,0	4,5	20578	2753			
6641	58,75	25		17	11	8,3	5,5	3,5	28053	3917			
6458	66,09	22		15	9,8	7,5	4,9	3,2	31169	4121			
6351	73,64	20		13	8,6	6,7	4,4	2,8	33792	4602			
5599	82,12	18		10	6,9	5,3	3,5	2,1	40409	5371			
5872	91,24	16		9,8	6,3	4,8	3,1	2,0	41241	5280			
5745	95,83	15		9,1	5,9	4,7	3,0	1,9	42954	5490			
5908	106,45	14		8,4	5,6	4,0	2,8	1,8	44476	5700			
10807	22,86	63	YRM3440	71	47	36	23	15	43940	1854	321	74	YR15
10641	27,05	54		65	43	32	21	14	44177	2008			
10314	27,73	52		56	37	28	18	12	44276	2008			
10404	30,79	47		51	33	25	16	11	44733	1713			
10576	34,19	42		47	30	23	15	9,9	44311	1781			
9954	37,71	38		40	25	20	13	8,4	44447	1867			
9626	42,15	34		35	22	17	11	7,2	44753	1525			
10003	47,10	31		32	20	15	9,9	6,5	43593	1589			
9364	52,24	28		27	18	15	8,5	5,6	49444	2690			
9098	57,00	34		24	16	12	8,0	5,1	50239	3017			
9188	60,87	24		23	15	11	7,5	4,8	54423	3352			
8885	66,64	22		20	13	9,9	6,3	4,3	58805	4023			
9595	74,15	20		20	13	9,8	6,4	4,1	58901	3694			
9229	81,85	18		17	11	8,5	5,6	3,7	63357	4389			
8104	90,41	16		14	9,2	7,1	4,7	2,9	71166	5304			
8374	100,75	14		13	8,4	6,4	4,2	2,7	69941	5220			
15000	22,74	64	YRM3500	100	66	50	32	21	58949	1889	429	75	YR16
14939	24,88	58		91	58	44	29	19	60871	1878			
15000	27,13	53		84	54	42	27	17	60832	1953			
14980	30,12	48		76	50	38	25	16	61625	1625			
13777	32,83	44		63	41	31	20	14	62119	1712			
13850	35,94	40		58	38	29	19	12	61660	1784			
13752	40,16	36		52	34	26	16	11	62288	1404			
13326	43,95	33		46	30	23	15	9,8	62484	1494			
14047	51,69	28		41	27	20	13	8,4	51489	1013			
14219	56,83	26		38	25	19	13	7,9	35510	1489			
14648	62,85	23		35	23	17	11	7,1	9294	2071			
13838	69,96	21		30	20	15	9,9	6,4	47696	2651			
13047	77,34	19		26	16	13	8,3	5,4	65499	3709			
13763	86,09	17		24	16	12	8,0	5,1	49719	4062			
13132	92,98	16		21	14	11	7,0	4,4	63874	4360			
12993	103,31	14		19	13	9,6	6,3	4,1	66520	4544			



## Y Serisi Güç Devir Sayfaları

### Y Series Performance Tables

### Y Serie Leistung und Drehzahlübersicht



Anma Momenti <i>Nominal Torques</i>  Nenn- drehmomente  Ma max.[Nm] n1=1450	Çevrim Oranı  Überset- zung	Çıkış Devri <i>Output Speeds</i>  Abtriebswelle Drehzahlen  n2 [r.p.m] n1=1450	Tipi <i>Type</i>  Typ	Termik Güç Pt [kW] ( Servis Faktörü fs = 1 için )  <i>Thermal Power Pt [kW] ( For Service Factor fs = 1 )</i>  Wärme-Grenzleistungen Pt [kW] ( Bei Betriebsfaktor fs = 1 )					Güv. Rad. Yük(Çık.)  <i>Per. Over. Loads (Out)</i>  Zul. Querkräfte (Ausgang)  Fqgv [N] n1=1450	Güv. Rad. Yük(Gir.)  <i>Per. Over. Loads(In)</i>  Zul Querkräfte (Eingang)  Fqgv [N] n1=1450	Ağırlık  <i>Weight</i>  Gewicht  ~ [kg]	Ölçü Sayfası  <i>Dim. Page</i>  Maße Seite	Fiyat Kodu  <i>Price Ref.</i>  Preis No
				n1=1450	n1=950	n1=725	n1=475	n1=360					
7852	21,78	67	YRM3395	27	25	24	23	22	23621	2993	225	73	YR14
7900	23,92	61		27	24	23	22	22	23542	2801			
7900	26,84	54		26	24	23	22	21	22704	2863			
7900	29,44	49		26	23	23	22	21	22560	2926			
7900	36,02	40		24	22	22	21	20	21846	2457			
7589	38,94	37		24	23	22	21	21	20793	2491			
7708	42,92	34		24	23	22	21	21	20275	2557			
7548	47,91	30		23	22	22	21	20	18818	2170			
7556	53,03	27		23	22	21	21	20	20578	2753			
6641	58,75	25		23	22	21	20	20	28053	3917			
6458	66,09	22		23	22	21	20	20	31169	4121			
6351	73,64	20		22	21	21	20	20	33792	4602			
5599	82,12	18		22	21	20	20	20	40409	5371			
5872	91,24	16		21	21	20	20	19	41241	5280			
5745	95,83	15	21	21	20	20	19	42954	5490				
5908	106,45	14	21	20	20	19	19	44476	5700				
10807	22,86	63	YRM3440	36	33	32	30	29	43940	1854	321	74	YR15
10641	27,05	54		35	32	31	30	29	44177	2008			
10314	27,73	52		35	32	31	30	29	44276	2008			
10404	30,79	47		33	32	31	29	28	44733	1713			
10576	34,19	42		33	31	30	29	28	44311	1781			
9954	37,71	38		33	31	30	28	28	44447	1867			
9626	42,15	34		31	30	29	28	27	44753	1525			
10003	47,10	31		31	30	29	28	27	43593	1589			
9364	52,24	28		31	29	28	27	27	49444	2690			
9098	57,00	34		32	30	29	28	27	50239	3017			
9188	60,87	24		31	30	29	28	27	54423	3352			
8885	66,64	22		31	30	29	28	28	58805	4023			
9595	74,15	20		30	29	29	28	27	58901	3694			
9229	81,85	18		30	29	28	27	27	63357	4389			
8104	90,41	16	30	29	28	27	27	71166	5304				
8374	100,75	14	30	29	28	27	27	69941	5220				
15000	22,74	64	YRM3500	47	43	41	39	37	58949	1889	429	75	YR16
14939	24,88	58		44	41	40	37	36	60871	1878			
15000	27,13	53		43	41	39	37	36	60832	1953			
14980	30,12	48		41	40	38	36	35	61625	1625			
13777	32,83	44		41	39	38	36	35	62119	1712			
13850	35,94	40		41	39	37	35	35	61660	1784			
13752	40,16	36		39	38	36	35	34	62288	1404			
13326	43,95	33		38	37	36	34	34	62484	1494			
14047	51,69	28		39	37	36	34	33	51489	1013			
14219	56,83	26		38	37	35	34	33	35510	1489			
14648	62,85	23		38	36	35	34	33	9294	2071			
13838	69,96	21		37	35	34	33	32	47696	2651			
13047	77,34	19		36	35	34	33	32	65499	3709			
13763	86,09	17		36	34	33	32	32	49719	4062			
13132	92,98	16	36	34	33	32	31	63874	4360				
12993	103,31	14	35	34	33	32	31	66520	4544				



## Y Serisi Güç Devir Sayfaları

### Y Series Performance Tables

### Y Serie Leistung und Drehzahlübersicht



Anma Momenti <i>Nominal Torques</i>  Nenn-drehmomente  Ma max.[Nm] n1=1450	Çevrim Oranı <i>Ratio</i>  Übersetzung	Çıkış Devri <i>Output Speeds</i>  Abtriebswelle Drehzahlen  n2 [r.p.m] n1=1450	Tipi <i>Type</i>  Typ	Nominal Güç Pe [kW] ( Servis Faktörü fs = 1 için )  <i>Nominal Power Pe [kW] ( For Service Factor fs = 1 )</i>  Nominal Leistung Pe [kW] ( Bei Betriebsfaktor fs = 1 )					Güv. Rad. Yük(Çık.)  <i>Per. Over. Loads (Out)</i>  Zul. Querkräfte (Ausgang)  Fqgv [N] n1=1450	Güv. Rad. Yük(Gir.)  <i>Per. Over. Loads(In)</i>  Zul Querkräfte (Eingang)  Fqgv [N] n1=1450	Ağırlık  <i>Weight</i>  Gewicht  ~ [kg]	Ölçü Sayfası  <i>Dim. Page</i>  Maße Seite	Fiyat Kodu  <i>Price Ref.</i>  Preis No
				n1=1450	n1=950	n1=725	n1=475	n1=360					
20000	22,46	65	YRM3555	135	89	68	44	29	75389	2455	660	76	YR17
20000	25,20	58		121	79	60	40	26	76894	2125			
20000	27,64	52		110	72	55	36	23	76990	2206			
20000	30,16	48		101	66	50	33	21	77924	2294			
20000	32,60	44		92	60	45	30	20	75586	1483			
20000	35,93	40		84	55	42	27	17	75092	1573			
19155	39,35	37		75	48	37	24	15	75774	1678			
19066	43,56	33		67	43	34	22	14	76366	1294			
19318	48,26	30		61	40	30	20	13	74875	1379			
16992	53,10	27		49	32	24	16	10	77774	1890			
17804	59,16	25		47	31	23	15	9,8	73811	1504			
17736	65,97	22		41	27	21	14	8,5	75180	2511			
15717	72,99	20		33	22	17	11	7,0	97566	4124			
16071	76,67	19		32	21	16	10	6,6	98828	4028			
15075	85,56	17		27	18	14	8,9	5,8	107937	5084			
16201	95,03	15		26	17	13	8,6	5,5	100165	4815			
26714	21,33	68	YRM3620	190	125	94	61	39	90548	1494	825	77	YR18
26931	23,43	62		174	113	86	56	36	91007	1606			
27000	25,85	56		158	101	77	51	33	91301	1719			
25220	31,54	46		121	79	59	39	25	94100	1461			
24802	35,24	41		107	69	52	34	22	95578	1019			
25338	39,09	37		98	63	48	32	20	95109	1125			
27000	44,47	33		92	60	46	30	19	95083	1014			
27000	47,48	31		86	57	43	28	18	91171	-			
27000	51,98	28		79	52	39	26	17	87088	3657			
27000	56,51	26		73	48	37	24	15	89805	-			
25884	62,38	23		64	42	33	21	13	93434	-			
25587	68,90	21		57	37	29	19	12	99826	1379			
24110	75,21	19		49	32	24	16	10	111466	2860			
25062	83,57	17		46	30	22	15	9,5	114508	2675			
23624	93,46	16		38	25	19	13	8,1	125846	4089			
22265	102,51	14		33	21	16	10	7,0	136684	5099			
43000	23,25	62	YRM3705	284	186	142	93	60	127860	1945	1345	78	YR19
43000	25,35	57		261	171	131	86	56	130185	1628			
43000	27,63	52		237	156	119	78	51	131635	1744			
43000	30,11	48		218	143	109	71	45	133955	1879			
42590	32,96	44		196	128	98	63	41	136376	1523			
42950	36,07	40		181	119	90	59	38	137432	1636			
40519	39,46	37		154	101	78	50	32	139704	1775			
40332	43,40	33		142	93	71	46	29	141976	1371			
39259	47,72	30		124	81	63	42	26	142586	1479			
37848	52,46	28		111	71	54	35	23	141675	1623			
37428	58,01	25		98	65	49	31	21	130210	1162			
37938	64,13	23		90	59	45	29	19	111325	1265			
33563	70,89	20		72	48	36	24	16	111023	2338			
34381	78,91	18		66	41	31	20	14	104619	2295			
33016	87,41	17		57	37	29	19	11	115032	3670			
32911	102,56	14		49	31	24	16	10	115778	3796			
6603	107,94	13	YRM4395	9,1	6,0	4,6	3,0	2,0	59495	1474	220	79	YR20
6630	120,43	12		8,4	5,5	4,1	2,6	1,7	61867	1459			
6483	132,07	11		7,5	5,0	3,7	2,4	1,6	65473	2170			
6700	142,80	10		7,1	4,5	3,5	2,2	1,3	66777	2314			
6700	157,36	9,2		6,5	4,2	3,2	2,1	1,2	70502	2580			
6700	175,65	8,3		5,8	3,7	2,9	1,9	1,2	74196	2873			
6651	194,43	7,5		5,2	3,4	2,6	1,7	1,1	77873	3126			
5773	215,42	6,7		4,0	2,7	2,0	1,4	0,93	86719	3604			
5992	243,92	5,9		3,7	2,4	1,9	1,2	0,82	88040	3421			
6100	270,25	5,4		3,4	2,2	1,7	1,1	0,62	86758	3577			



## Y Serisi Güç Devir Sayfaları

### Y Series Performance Tables

### Y Serie Leistung und Drehzahlübersicht



Anma Momenti <i>Nominal Torques</i>	Çevrim Oranı <i>Ratio</i>  Übersetzung	Çıkış Devri <i>Output Speeds</i>  Abtriebswelle Drehzahlen	Tipi <i>Type</i>  Typ	Termik Güç Pt [kW] ( Servis Faktörü fs = 1 için )  <i>Thermal Power Pt [kW] ( For Service Factor fs = 1 )</i>  Wärme-Grenzleistungen Pt [kW] ( Bei Betriebsfaktor fs = 1 )					Güv. Rad. Yük(Çık.) <i>Per. Over. Loads (Out)</i>	Güv. Rad. Yük(Gir.) <i>Per. Over. Loads(In)</i>	Ağırlık <i>Weight</i>	Ölçü Sayfası <i>Dim. Page</i>	Fiyat Kodu <i>Price Ref.</i>
									Zul. Querkräfte (Ausgang)	Zul Querkräfte (Eingang)	Gewicht	Maße Seite	Preis No
				Ma max.[Nm] n1=1450	n2 [r.p.m] n1=1450	n1=1450	n1=950	n1=725	n1=475	n1=360	Fqgv [N] n1=1450	Fqgv [N] n1=1450	~ [kg]
<b>20000</b>	22,46	65	<b>YRM3555</b>	<b>55</b>	53	50	47	46	75389	2455	660	76	YR17
<b>20000</b>	25,20	58		<b>53</b>	51	49	46	45	76894	2125			
<b>20000</b>	27,64	52		<b>52</b>	50	48	46	44	76990	2206			
<b>20000</b>	30,16	48		<b>52</b>	50	48	45	44	77924	2294			
<b>20000</b>	32,60	44		<b>54</b>	50	48	46	44	75586	1483			
<b>20000</b>	35,93	40		<b>53</b>	50	48	45	44	75092	1573			
<b>19155</b>	39,35	37		<b>52</b>	49	47	45	44	75774	1678			
<b>19066</b>	43,56	33		<b>51</b>	48	46	44	43	76366	1294			
<b>19318</b>	48,26	30		<b>50</b>	47	45	43	42	74875	1379			
<b>16992</b>	53,10	27		<b>49</b>	47	45	43	42	77774	1890			
<b>17804</b>	59,16	25		<b>48</b>	45	44	42	41	73811	1504			
<b>17736</b>	65,97	22		<b>47</b>	45	43	42	41	75180	2511			
<b>15717</b>	27,37	53		<b>51</b>	48	46	43	42	97566	4124			
<b>16071</b>	76,67	19		<b>47</b>	44	43	41	41	98828	4028			
<b>15075</b>	85,56	17		<b>47</b>	45	43	42	41	107937	5084			
<b>16201</b>	95,03	15		<b>45</b>	44	42	41	40	100165	4815			
<b>26714</b>	21,33	68	<b>YRM3620</b>	<b>74</b>	70	66	62	60	90548	1494	825	77	YR18
<b>26931</b>	23,43	62		<b>73</b>	68	65	61	59	91007	1606			
<b>27000</b>	25,85	56		<b>72</b>	67	64	60	58	91301	1719			
<b>25220</b>	31,54	46		<b>69</b>	65	62	58	57	94100	1461			
<b>24802</b>	35,24	41		<b>66</b>	63	60	57	56	95578	1019			
<b>25338</b>	39,09	37		<b>65</b>	62	59	56	55	95109	1125			
<b>27000</b>	44,47	33		<b>66</b>	62	60	57	55	95083	1014			
<b>27000</b>	47,48	31		<b>68</b>	63	61	58	56	91171	-			
<b>27000</b>	51,98	28		<b>70</b>	65	63	60	58	87088	3657			
<b>27000</b>	56,51	26		<b>67</b>	63	61	58	56	89805	-			
<b>25884</b>	62,38	23		<b>65</b>	61	59	57	55	93434	-			
<b>25587</b>	68,90	21		<b>64</b>	60	58	56	55	99826	1379			
<b>24110</b>	75,21	19		<b>63</b>	60	58	55	54	111466	2860			
<b>25062</b>	83,57	17		<b>61</b>	58	57	54	53	114508	2675			
<b>23624</b>	93,46	16		<b>60</b>	58	57	55	53	125846	4089			
<b>22265</b>	102,51	14		<b>60</b>	58	56	54	53	136684	5099			
<b>43000</b>	23,25	62	<b>YRM3705</b>	<b>97</b>	89	84	78	75	127860	1945	1345	78	YR19
<b>43000</b>	25,35	57		<b>93</b>	87	82	77	74	130185	1628			
<b>43000</b>	27,63	52		<b>92</b>	85	81	76	73	131635	1744			
<b>43000</b>	30,11	48		<b>91</b>	84	80	75	72	133955	1879			
<b>42590</b>	32,96	44		<b>88</b>	82	78	74	71	136376	1523			
<b>42950</b>	36,07	40		<b>87</b>	81	77	73	70	137432	1636			
<b>40519</b>	39,46	37		<b>86</b>	80	76	72	70	139704	1775			
<b>40332</b>	43,40	33		<b>83</b>	78	75	71	68	141976	1371			
<b>39259</b>	47,72	30		<b>82</b>	77	74	70	68	142586	1479			
<b>37848</b>	52,46	28		<b>81</b>	76	73	69	67	141675	1623			
<b>37428</b>	58,01	25		<b>78</b>	74	71	68	66	130210	1162			
<b>37938</b>	64,13	23		<b>77</b>	73	70	67	65	111325	1265			
<b>33563</b>	70,89	20		<b>76</b>	72	69	66	64	111023	2338			
<b>34381</b>	78,91	18		<b>73</b>	70	68	65	63	104619	2295			
<b>33016</b>	87,41	17		<b>73</b>	70	68	65	64	115032	3670			
<b>32911</b>	102,56	14		<b>73</b>	70	68	65	63	115778	3796			
<b>6603</b>	107,94	13	<b>YRM4395</b>	<b>22</b>	21	20	19	19	59495	1474	220	79	YR20
<b>6630</b>	120,43	12		<b>21</b>	21	20	19	19	61867	1459			
<b>6483</b>	132,07	11		<b>21</b>	20	20	19	19	65473	2170			
<b>6700</b>	142,80	10		<b>22</b>	21	20	20	19	66777	2314			
<b>6700</b>	157,36	9,2		<b>22</b>	21	20	20	19	70502	2580			
<b>6700</b>	175,65	8,3		<b>22</b>	21	20	20	19	74196	2873			
<b>6651</b>	194,43	7,5		<b>21</b>	20	20	19	19	77873	3126			
<b>5773</b>	215,42	6,7		<b>21</b>	21	20	19	19	86719	3604			
<b>5992</b>	243,92	5,9		<b>20</b>	20	19	19	19	88040	3421			
<b>6100</b>	270,25	5,4		<b>20</b>	20	19	19	19	86758	3577			



## Y Serisi Güç Devir Sayfaları

### Y Series Performance Tables

### Y Serie Leistung und Drehzahlübersicht



Anma Momenti <i>Nominal Torques</i>	Çevrim Oranı <i>Ratio</i>	Çıkış Devri <i>Output Speeds</i>	Tipi <i>Type</i>	Nominal Güç Pe [kW] ( Servis Faktörü fs = 1 için )					Güv. Rad. Yük(Çık.) <i>Per. Over. Loads (Out)</i>	Güv. Rad. Yük(Gir.) <i>Per. Over. Loads(In)</i>	Ağırlık <i>Weight</i>	Ölçü Sayfası <i>Dim. Page</i>	Fiyat Kodu <i>Price Ref.</i>		
				Nominal Power Pe [kW] ( For Service Factor fs = 1 )										Zul. Querkräfte (Ausgang)	Zul Querkräfte (Eingang)
				Nominal Leistung Pe [kW] ( Bei Betriebsfaktor fs = 1 )											
Nenn- drehmomente	Überset- zung	Abtriebswelle Drehzahlen	Typ	n1=1450	n1=950	n1=725	n1=475	n1=360	Gewicht	Maße Seite	Preis No				
Ma max.[Nm] n1=1450		n2 [r.p.m] n1=1450							~ [kg]						
5826	304,03	4,8	YRM4395	2,9	1,9	1,5	0,95	0,62	89928	3838	220	79	YR21		
5550	338,73	4,3		2,5	1,7	1,3	0,84	0,51	92858	4047					
5143	377,73	3,8		2,1	1,5	0,97	0,63	0,41	96775	4255					
5132	419,70	3,5		1,9	1,2	0,87	0,53	0,36	96874	4360					
5403	440,83	3,3		1,9	1,2	0,87	0,53	0,31	94331	4360					
5798	500,46	2,9		1,8	1,1	0,77	0,42	0,31	90229	4313					
10500	104,20	14	YRM4440	15	9,9	7,4	4,7	3,2	78897	2106	295	80	YR22		
10500	115,71	13		14	8,9	6,7	4,3	2,8	81121	2570					
10348	127,65	11		12	7,7	6,0	3,9	2,5	83742	2982					
10345	142,65	10		11	7,3	5,6	3,4	2,2	83797	3300					
9371	159,41	9,1		8,9	5,7	4,4	2,8	1,9	98217	3901					
9509	176,25	8,2		8,2	5,4	4,2	2,7	1,6	96394	4113					
9514	196,96	7,4		7,3	4,7	3,5	2,4	1,5	96316	4361					
8882	218,46	6,6		6,2	4,1	3,0	2,0	1,2	104247	4679					
8767	238,40	6,1		5,6	3,8	2,8	1,9	1,1	105565	4856					
9184	254,55	5,7		5,5	3,7	2,7	1,8	1,1	100597	4891					
9364	278,68	5,2		5,1	3,3	2,4	1,6	1,0	98313	4997					
8628	310,10	4,7		4,2	2,7	2,2	1,4	0,93	107120	5245					
8678	342,28	4,2		3,9	2,3	1,9	1,3	0,86	106558	5351					
7736	378,07	3,8		3,1	2,0	1,5	1,0	0,74	116060	5563					
7582	421,32	3,4		2,7	1,9	1,4	0,89	0,62	117440	5669					
7736	467,11	3,2		2,6	1,8	1,3	0,76	0,49	116060	5519					
8186	486,96	2,9		2,5	1,6	1,2	0,76	0,49	111760	5563					
14489	118,38	12	YRM4500	19	13	9,2	6,1	3,9	23592	1055	415	81	YR23		
13770	128,59	11		16	11	8,0	5,3	3,5	50868	2246					
14047	143,26	10		15	9,8	7,5	4,8	3,1	42637	2214					
13752	175,26	8,3		12	7,7	6,3	3,9	2,6	51353	3141					
13202	191,77	7,6		10	6,7	5,5	3,4	2,2	64186	3604					
13236	210,92	6,9		9,6	6,3	4,6	3,2	2,0	63474	3875					
13007	225,57	6,4		8,7	6,0	4,3	2,9	1,9	68047	4145					
12026	247,98	5,8		7,3	4,9	3,6	2,3	1,5	84186	4570					
12148	278,46	5,2		6,6	4,2	3,2	2,0	1,4	82416	4597					
12900	307,95	4,7		6,3	3,9	3,0	1,9	1,2	70059	4682					
11792	342,80	4,2		5,2	3,5	2,7	1,6	1,1	87424	5065					
11418	378,95	3,8		4,6	2,9	2,2	1,4	0,93	92256	5277					
11372	421,83	3,4		4,1	2,7	2,1	1,3	0,89	92821	5447					
11571	455,58	3,2		3,9	2,4	1,9	1,1	0,74	90329	5532					
11988	506,20	2,9		3,6	2,0	1,7	1,0	0,62	84721	5617					
24000	97,37	15	YRM4555	36	24	18	12	7,8	104707	-	661	82	YR24		
24000	108,59	13		33	22	17	11	7,0	109849	-					
24000	118,46	12		30	20	15	9,8	6,5	116246	1113					
24000	132,92	11		28	18	14	9,1	5,9	120799	1682					
24000	143,72	10		25	17	13	8,3	5,4	126779	2345					
22490	157,40	9,2		22	14	11	7,1	4,7	106261	3211					
22647	174,23	8,3		20	13	9,6	6,5	3,9	109242	3695					
22276	193,04	7,5		18	11	8,8	5,8	3,7	102067	4239					
20477	212,40	6,8		15	9,4	7,3	4,8	3,1	58478	4935					
21700	241,29	6,0		14	8,1	6,4	4,2	2,8	90080	4511					
20174	265,50	5,5		12	7,5	5,8	3,8	2,5	47917	5129					
19975	295,80	4,9		10	6,8	5,3	3,4	2,2	39613	5492					
19868	329,87	4,4		9,2	6,1	4,6	3,0	2,0	34399	5818					
17927	364,96	4,0		7,5	4,9	3,8	2,5	1,6	74134	6327					
18184	383,33	3,8		7,2	4,8	3,6	2,4	1,6	68199	6399					
18568	427,78	3,4		6,6	4,3	3,2	2,2	1,5	58002	6581					
18275	475,15	3,1		5,8	3,8	2,9	1,9	1,2	65952	6799					
16022	529,15	2,7		4,6	3,0	2,2	1,5	1,0	106684	7162					





## Y Serisi Güç Devir Sayfaları

### Y Series Performance Tables

### Y Serie Leistung und Drehzahlübersicht



Anma Momenti <i>Nominal Torques</i>	Çevrim Oranı <i>Ratio</i>  Übersetzung	Çıkış Devri <i>Output Speeds</i>  Abtriebswelle Drehzahlen	Tipi <i>Type</i>  Typ	Termik Güç Pt [kW] ( Servis Faktörü fs = 1 için )  <i>Thermal Power Pt [kW] ( For Service Factor fs = 1 )</i>  Wärme-Grenzleistungen Pt [kW] ( Bei Betriebsfaktor fs = 1 )					Güv. Rad. Yük(Çık.) <i>Per. Over. Loads (Out)</i>	Güv. Rad. Yük(Gir.) <i>Per. Over. Loads(In)</i>	Ağırlık <i>Weight</i>	Ölçü Sayfası <i>Dim. Page</i>	Fiyat Kodu <i>Price Ref.</i>
									Zul. Querkräfte (Ausgang)	Zul Querkräfte (Eingang)	Gewicht	Maße Seite	Preis No
				Ma max.[Nm] n1=1450	n2 [r.p.m] n1=1450	n1=1450	n1=950	n1=725	n1=475	n1=360	Fqgv [N] n1=1450	Fqgv [N] n1=1450	~ [kg]
<b>5826</b>	304,03	4,8	<b>YRM4395</b>	<b>20</b>	20	19	19	19	89928	3838	220	79	YR21
<b>5550</b>	338,73	4,3		<b>20</b>	19	19	19	18	92858	4047			
<b>5143</b>	377,73	3,8		<b>20</b>	19	19	19	18	96775	4255			
<b>5132</b>	419,70	3,5		<b>20</b>	19	19	18	18	96874	4360			
<b>5403</b>	440,83	3,3		<b>20</b>	19	19	19	18	94331	4360			
<b>5798</b>	500,46	2,9		<b>19</b>	19	19	18	18	90229	4313			
<b>10500</b>	104,20	14	<b>YRM4440</b>	<b>29</b>	28	27	27	26	78897	2106	295	80	YR22
<b>10500</b>	115,71	13		<b>29</b>	28	27	27	26	81121	2570			
<b>10348</b>	127,65	11		<b>29</b>	28	27	26	26	83742	2982			
<b>10345</b>	142,65	10		<b>29</b>	28	27	26	26	83797	3300			
<b>9371</b>	159,41	9,1		<b>29</b>	28	27	26	26	98217	3901			
<b>9509</b>	176,25	8,2		<b>28</b>	27	27	26	25	96394	4113			
<b>9514</b>	196,96	7,4		<b>28</b>	27	26	25	25	96316	4361			
<b>8882</b>	218,46	6,6		<b>28</b>	27	26	25	25	104247	4679			
<b>8767</b>	238,40	6,1		<b>28</b>	27	26	26	25	105565	4856			
<b>9184</b>	254,55	5,7		<b>28</b>	28	27	26	26	100597	4891			
<b>9364</b>	278,68	5,2		<b>28</b>	28	27	26	26	98313	4997			
<b>8628</b>	310,10	4,7		<b>29</b>	27	27	26	26	107120	5245			
<b>8678</b>	342,28	4,2		<b>28</b>	27	26	26	25	106558	5351			
<b>7736</b>	378,07	3,8		<b>28</b>	27	26	26	25	116060	5563			
<b>7582</b>	421,32	3,4		<b>28</b>	27	27	26	25	117440	5669			
<b>7736</b>	452,05	3,2		<b>27</b>	26	26	25	25	116060	5519			
<b>8186</b>	503,75	2,9		<b>27</b>	27	26	26	25	111760	5563			
<b>14489</b>	118,38	12	<b>YRM4500</b>	<b>35</b>	34	33	32	32	23592	1055	415	81	YR23
<b>13770</b>	128,59	11		<b>36</b>	35	34	32	32	50868	2246			
<b>14047</b>	143,26	10		<b>35</b>	34	33	32	31	42637	2214			
<b>13752</b>	175,26	8,3		<b>35</b>	33	32	31	31	51353	3141			
<b>13202</b>	191,77	7,6		<b>35</b>	33	32	31	31	64186	3604			
<b>13236</b>	210,92	6,9		<b>34</b>	33	32	31	30	63474	3875			
<b>13007</b>	225,57	6,4		<b>34</b>	33	32	31	31	68047	4145			
<b>12026</b>	247,98	5,8		<b>34</b>	33	32	31	31	84186	4570			
<b>12148</b>	278,46	5,2		<b>33</b>	32	32	31	30	82416	4597			
<b>12900</b>	307,95	4,7		<b>32</b>	32	31	30	30	70059	4682			
<b>11792</b>	342,80	4,2		<b>32</b>	31	31	30	30	87424	5065			
<b>11418</b>	378,95	3,8		<b>32</b>	31	31	30	30	92256	5277			
<b>11372</b>	421,83	3,4		<b>32</b>	31	31	30	29	92821	5447			
<b>11571</b>	455,58	3,2		<b>32</b>	31	30	30	29	90329	5532			
<b>11988</b>	506,20	2,9		<b>32</b>	31	30	30	29	84721	5617			
<b>24000</b>	97,37	15	<b>YRM4555</b>	<b>47</b>	44	42	41	40	104707	-	661	82	YR24
<b>24000</b>	108,59	13		<b>46</b>	43	42	40	40	109849	-			
<b>24000</b>	118,46	12		<b>46</b>	43	42	40	40	116246	1113			
<b>24000</b>	132,92	11		<b>46</b>	44	43	41	40	120799	1682			
<b>24000</b>	143,72	10		<b>46</b>	44	42	41	40	126779	2345			
<b>22490</b>	157,40	9,2		<b>46</b>	44	42	41	40	106261	3211			
<b>22647</b>	174,23	8,3		<b>45</b>	43	42	40	40	109242	3695			
<b>22276</b>	193,04	7,5		<b>45</b>	43	41	40	39	102067	4239			
<b>20477</b>	212,40	6,8		<b>45</b>	43	41	40	39	58478	4935			
<b>21700</b>	241,29	6,0		<b>43</b>	41	40	39	38	90080	4511			
<b>20174</b>	265,50	5,5		<b>43</b>	41	40	39	38	47917	5129			
<b>19975</b>	295,80	4,9		<b>42</b>	41	40	39	38	39613	5492			
<b>19868</b>	329,87	4,4		<b>42</b>	40	39	38	38	34399	5818			
<b>17927</b>	364,96	4,0		<b>42</b>	40	39	38	38	74134	6327			
<b>18184</b>	383,33	3,8		<b>42</b>	40	40	39	38	68199	6399			
<b>18568</b>	427,78	3,4		<b>42</b>	41	40	39	38	58002	6581			
<b>18275</b>	475,15	3,1		<b>42</b>	40	39	38	38	65952	6799			
<b>16022</b>	529,15	2,7		<b>42</b>	40	39	38	38	106684	7162			



## Y Serisi Güç Devir Sayfaları

### Y Series Performance Tables

#### Y Serie Leistung und Drehzahlübersicht



Anma Momenti <i>Nominal Torques</i>  Nenn- drehmomente  Ma max.[Nm] n1=1450	Çevrim Oranı  Überset- zung	Çıkış Devri <i>Output Speeds</i>  Abtriebswelle Drehzahlen  n2 [r.p.m] n1=1450	Tipi <i>Type</i>  Typ	Nominal Güç Pe [kW] ( Servis Faktörü fs = 1 için )  <i>Nominal Power Pe [kW] ( For Service Factor fs = 1 )</i>  Nominal Leistung Pe [kW] ( Bei Betriebsfaktor fs = 1 )					Güv. Rad. Yük(Çık.)  <i>Per. Over. Loads (Out)</i>  Zul. Querkräfte (Ausgang)  Fqgv [N] n1=1450	Güv. Rad. Yük(Gir.)  <i>Per. Over. Loads(In)</i>  Zul Querkräfte (Eingang)  Fqgv [N] n1=1450	Ağırlık  <i>Weight</i>  Gewicht  ~ [kg]	Ölçü Sayfası  <i>Dim. Page</i>  Maße Seite	Fiyat Kodu  <i>Price Ref.</i>  Preis No
				n1=1450	n1=950	n1=725	n1=475	n1=360					
28784	107,76	13	YRM4620	40	24	19	13	8,5	127769	-	780	83	YR25
26265	120,42	12		33	22	17	12	7,4	164383	2461			
28321	134,57	11		32	20	16	10	6,6	135503	2725			
26905	149,26	9,7		27	17	14	9,1	5,8	156194	3781			
29270	169,78	8,5		26	17	13	8,7	5,7	118943	4045			
30000	185,27	7,8		25	16	12	8,1	5,2	103968	4016			
30000	197,83	7,3		23	15	11	7,4	4,9	103968	4416			
30000	216,59	6,7		21	14	10	6,9	4,4	103968	4916			
28033	235,47	6,2		18	13	9,0	6,2	4,0	140049	5601			
28960	259,90	5,6		17	11	8,3	5,6	3,5	124657	5883			
27742	287,08	5,1		15	10	7,7	5,0	3,2	144452	6448			
27777	319,45	4,5		13	8,9	6,8	4,5	2,8	143930	6515			
23569	348,72	4,2		10	7,0	5,3	3,5	2,3	193355	7347			
25871	387,47	3,7		10	6,7	5,1	3,4	2,1	169128	7377			
27355	433,32	3,3		9,6	6,0	4,7	3,0	1,9	150040	7531			
25554	475,30	3,1		8,2	5,2	4,0	1,7	1,9	172807	7901			
24333	529,66	2,7		7,6	5,0	3,8	1,4	1,6	185912	7849			
43000	103,50	14	YRM4705	64	42	32	21	14	108614	-	1373	84	YR26
43000	112,80	13		58	38	29	19	12	108614	-			
42110	122,94	12		52	34	26	18	11	88609	-			
41532	134,59	11		47	31	23	15	10	73035	-			
41915	147,27	9,8		43	28	21	14	9,2	83652	1782			
39139	161,14	9,0		36	24	19	12	7,9	68735	3438			
40707	177,23	8,2		35	23	18	11	7,4	42406	3714			
39709	197,29	7,3		31	20	15	10	6,4	48808	4140			
39259	216,89	6,7		27	17	14	9,1	5,9	65070	5043			
35567	238,44	6,1		23	15	12	7,7	5,0	136468	6247			
39223	263,69	5,5		23	15	12	7,5	4,9	66192	6308			
40832	291,50	5,0		21	14	11	6,9	4,5	48275	6639			
34658	322,23	4,5		16	11	8,4	5,4	3,5	148147	7964			
34567	348,01	4,2		15	10	7,8	5,1	3,2	149248	7989			
35228	387,40	3,7		14	9,1	6,9	4,6	3,0	140976	8346			
37083	429,12	3,4		13	8,2	6,2	4,2	2,6	113513	8560			
36535	503,50	2,9		11	7,0	5,4	3,6	2,2	122421	9130			



## Y Serisi Güç Devir Sayfaları

### Y Series Performance Tables

### Y Serie Leistung und Drehzahlübersicht



Anma Momenti <i>Nominal Torques</i>	Çevrim Oranı <i>Ratio</i>  Übersetzung	Çıkış Devri <i>Output Speeds</i>  Abtriebswelle Drehzahlen	Tipi <i>Type</i>  Typ	Termik Güç Pt [kW] ( Servis Faktörü fs = 1 için )  <i>Thermal Power Pt [kW] ( For Service Factor fs = 1 )</i>  Wärme-Grenzleistungen Pt [kW] ( Bei Betriebsfaktor fs = 1 )					Güv. Rad. Yük(Çık.)  <i>Per. Over. Loads (Out)</i>	Güv. Rad. Yük(Gir.)  <i>Per. Over. Loads(In)</i>	Ağırlık  <i>Weight</i>	Ölçü Sayfası  <i>Dim. Page</i>	Fiyat Kodu  <i>Price Ref.</i>
									Zul. Querkräfte (Ausgang)	Zul Querkräfte (Eingang)	Gewicht	Maße Seite	Preis No
				Ma max.[Nm] n1=1450	n2 [r.p.m] n1=1450	n1=1450	n1=950	n1=725	n1=475	n1=360	Fqgv [N] n1=1450	Fqgv [N] n1=1450	~ [kg]
28784	107,76	13	YRM4620	59	56	54	52	51	127769	-	780	83	YR25
26265	120,42	12		59	56	54	52	51	164383	2461			
28321	134,57	11		58	55	54	52	50	135503	2725			
26905	149,26	9,7		57	55	53	51	50	156194	3781			
29270	169,78	8,5		57	55	53	51	50	118943	4045			
30000	185,27	7,8		58	55	53	51	50	103968	4016			
30000	197,83	7,3		58	56	54	52	51	103968	4416			
30000	216,59	6,7		58	56	54	53	51	103968	4916			
28033	235,47	6,2		58	56	54	53	51	140049	5601			
28960	259,90	5,6		58	55	54	52	51	124657	5883			
27742	287,08	5,1		57	55	53	51	51	144452	6448			
27777	319,45	4,5		55	54	52	51	50	143930	6515			
23569	348,72	4,2		55	54	52	51	50	193355	7347			
25871	387,47	3,7		55	53	52	50	49	169128	7377			
27355	433,32	3,3		55	53	52	50	49	150040	7531			
25554	475,30	3,1		55	53	52	50	49	172807	7901			
24333	529,66	2,7		56	53	52	50	50	185912	7849			
43000	103,50	14	YRM4705	76	74	71	68	66	108614	-	1373	84	YR26
43000	112,80	13		76	73	71	67	66	108614	-			
42110	122,94	12		76	73	71	67	66	88609	-			
41532	134,59	11		75	72	70	67	65	73035	-			
41915	147,27	9,8		73	69	67	65	63	83652	1782			
39139	161,14	9,0		74	71	69	66	65	68735	3438			
40707	177,23	8,2		74	70	68	65	64	42406	3714			
39709	197,29	7,3		71	69	67	64	63	48808	4140			
39259	216,89	6,7		70	68	66	64	62	65070	5043			
35567	238,44	6,1		70	68	66	64	62	136468	6247			
39223	263,69	5,5		70	67	65	63	62	66192	6308			
40832	291,50	5,0		69	66	65	62	61	48275	6639			
34658	322,23	4,5		69	66	65	62	61	148147	7964			
34567	348,01	4,2		68	66	64	62	61	149248	7989			
35228	387,40	3,7		68	65	63	61	60	140976	8346			
37083	429,12	3,4		68	65	64	62	61	113513	8560			
36535	503,50	2,9		68	66	64	62	61	122421	9130			





# Ölçü Sayfaları

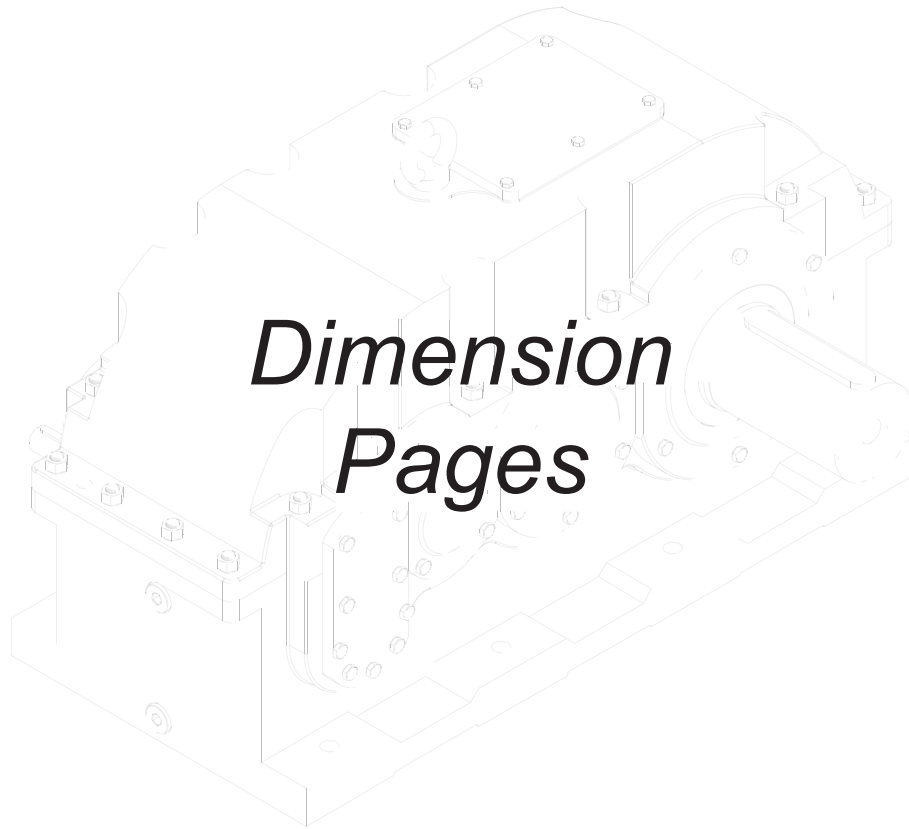

*Dimension  
Pages*

**Abmessungenseiten**





# Ölçü Sayfaları Dimension Pages Abmessungsseiten



-Mil ucu çektirme deliği DIN 332 sayfa 2 / Tapped center hole according to DIN 332, sheet 2 / Zentrierung mit Gewinde nach DIN 332, Blatt 2

YRM1125.□

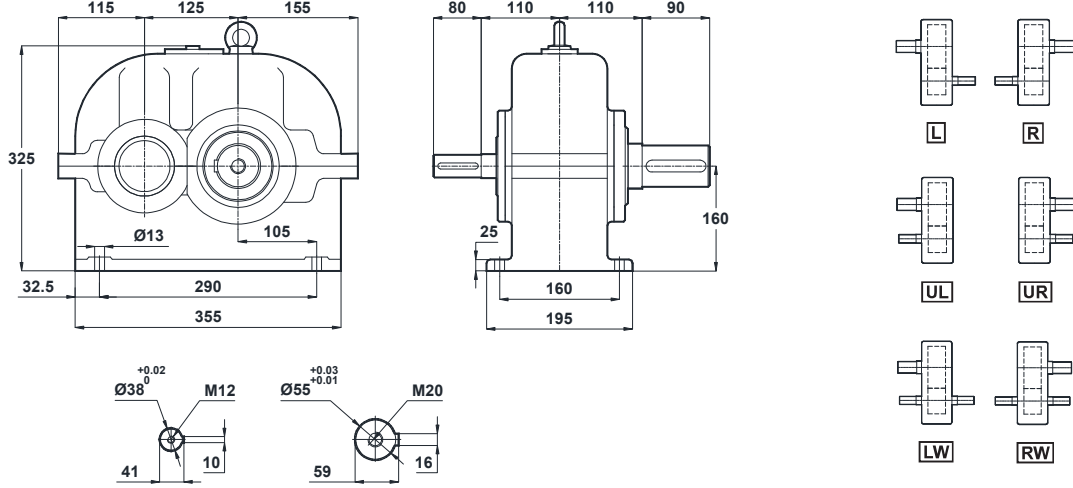

YRC1125.□

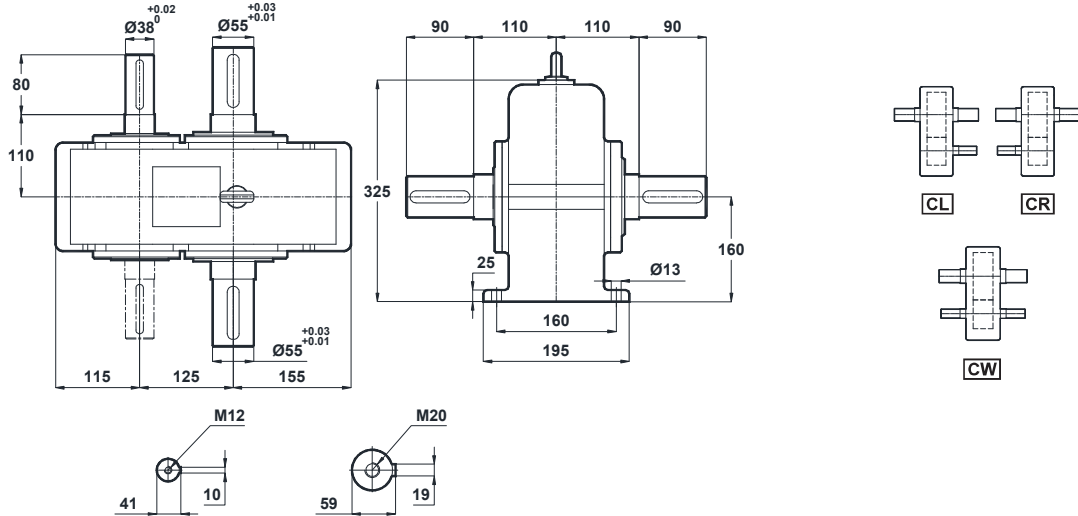



# Ölçü Sayfaları Dimension Pages Abmessungenseiten



-Mil ucu çekirme deliği DIN 332 sayfa 2 / Tapped center hole according to DIN 332, sheet 2 / Zentrierung mit Gewinde nach DIN 332, Blatt 2

YRM1160.□

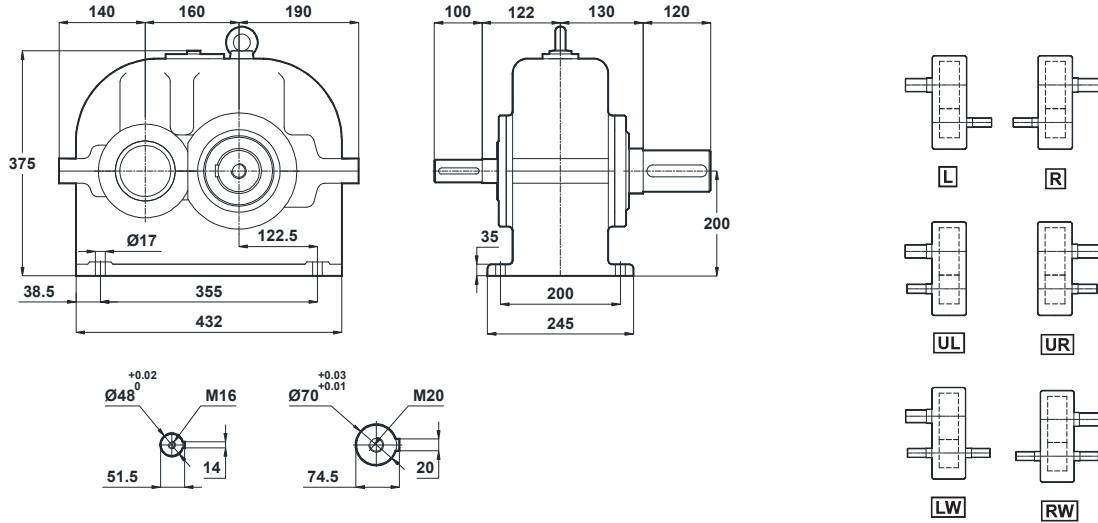

YRC1160.□

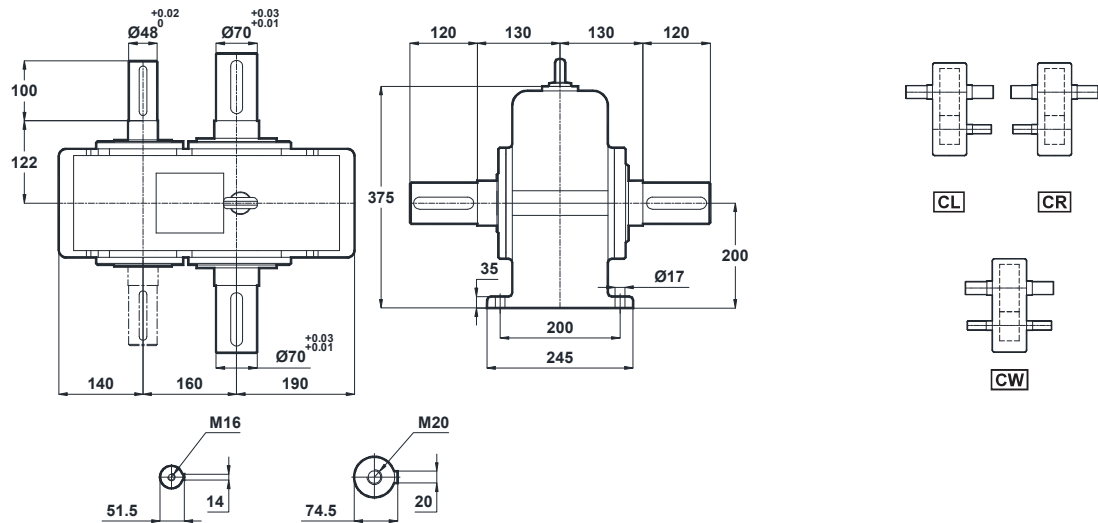



# Ölçü Sayfaları Dimension Pages Abmessungsseiten



-Mil ucu çektirme deliği DIN 332 sayfa 2 / Tapped center hole according to DIN 332, sheet 2 / Zentrierung mit Gewinde nach DIN 332, Blatt 2

YRM1200.□

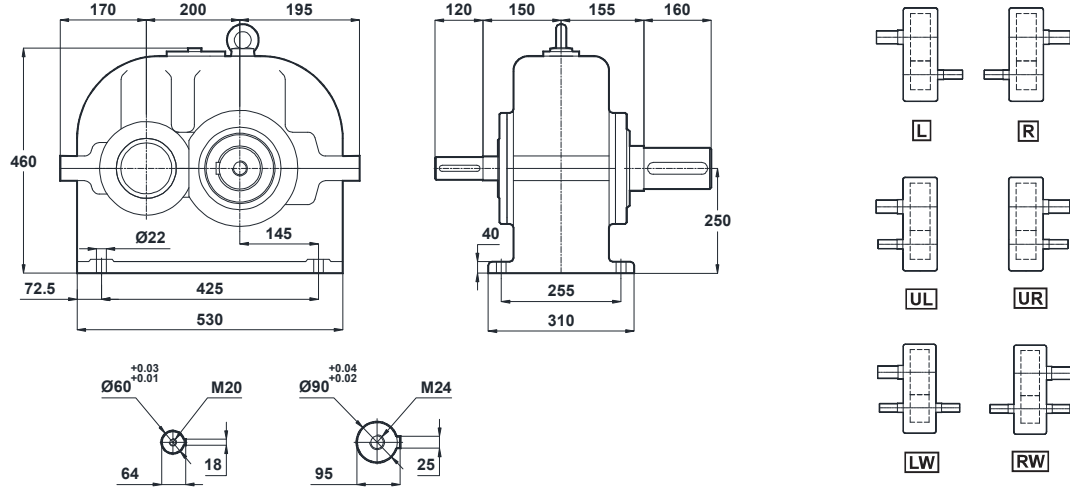

YRC1200.□

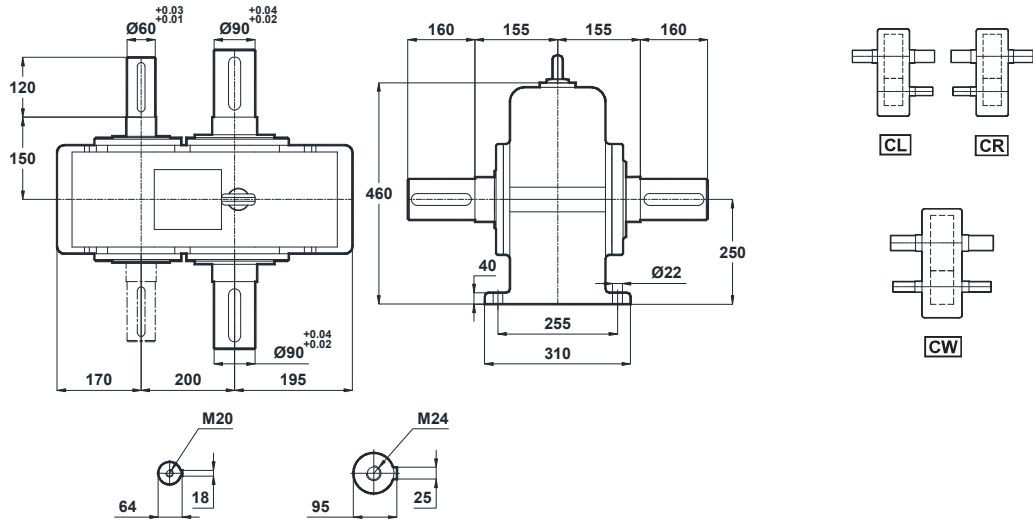



# Ölçü Sayfaları Dimension Pages Abmessungsseiten



-Mil ucu çekirme deliği DIN 332 sayfa 2 / Tapped center hole according to DIN 332, sheet 2 / Zentrierung mit Gewinde nach DIN 332, Blatt 2

YRM2195.□

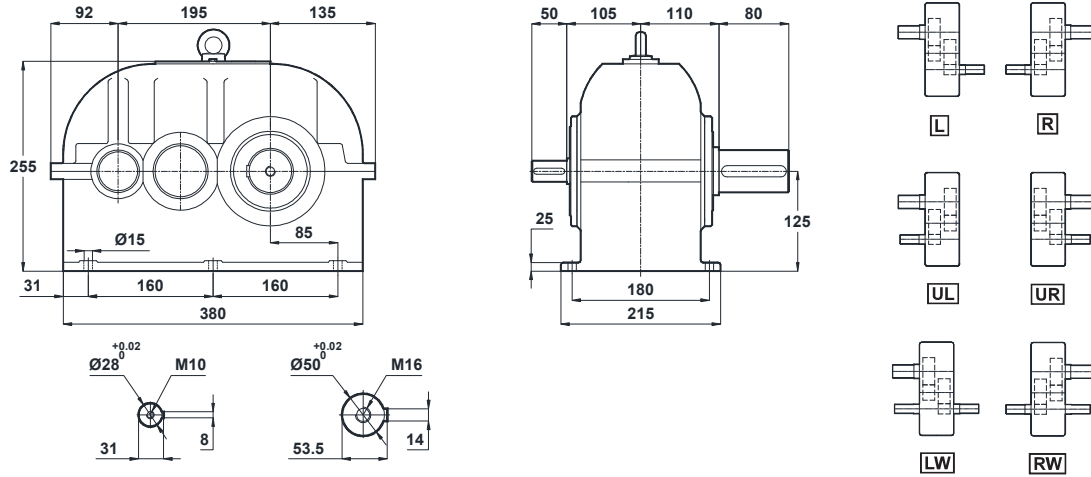

YRC2195.□

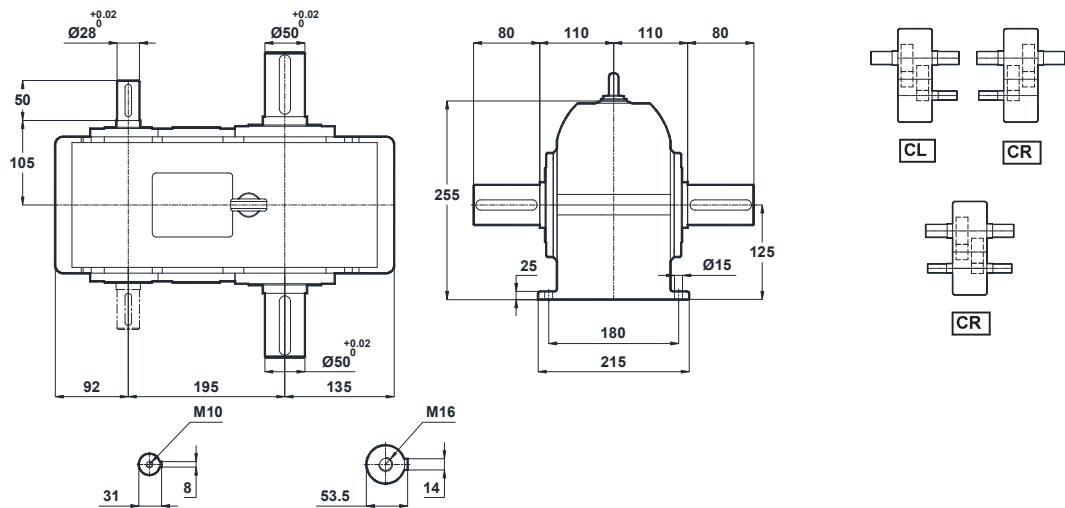



# Ölçü Sayfaları Dimension Pages Abmessungsseiten



-Mil ucu çektirme deliği DIN 332 sayfa 2 / Tapped center hole according to DIN 332, sheet 2 / Zentrierung mit Gewinde nach DIN 332, Blatt 2

YRM2240.□

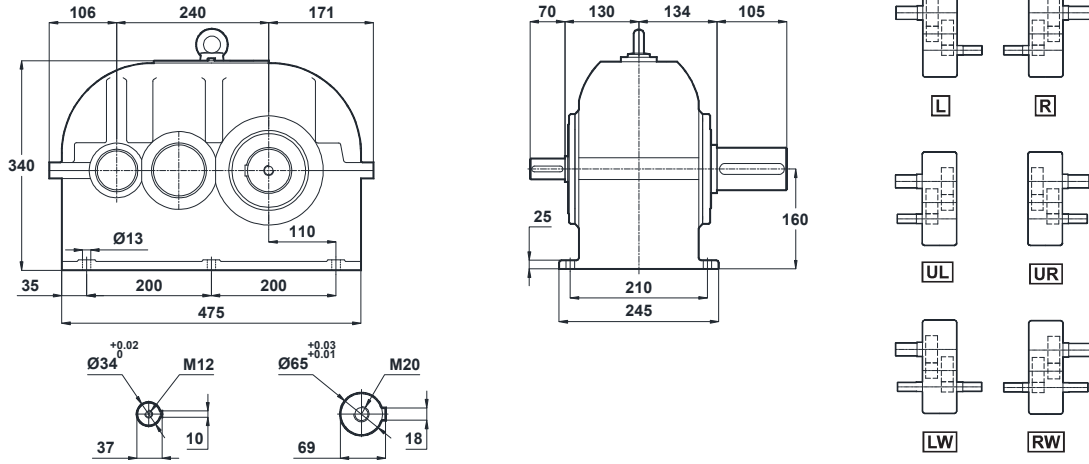

YRC2240.□

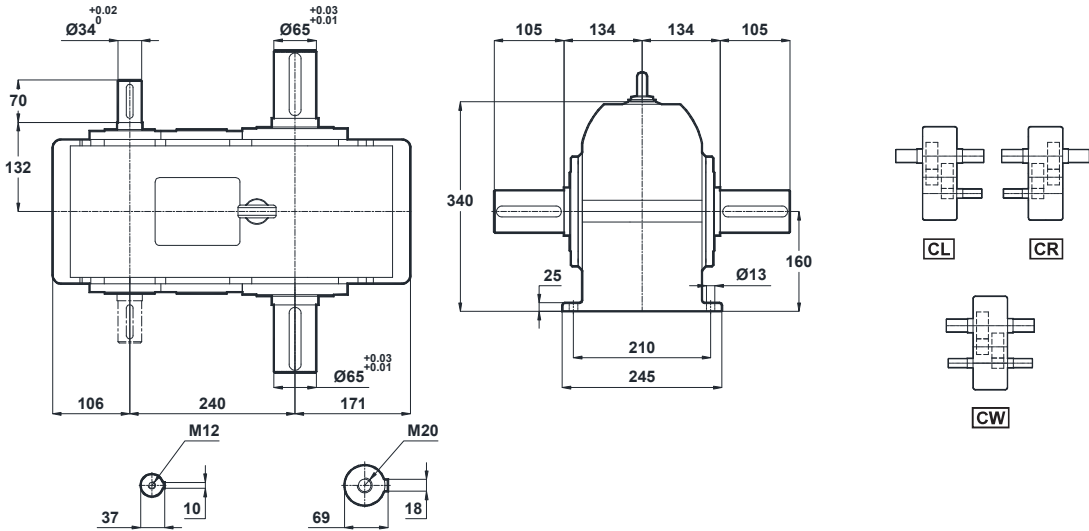

YRD2240.□

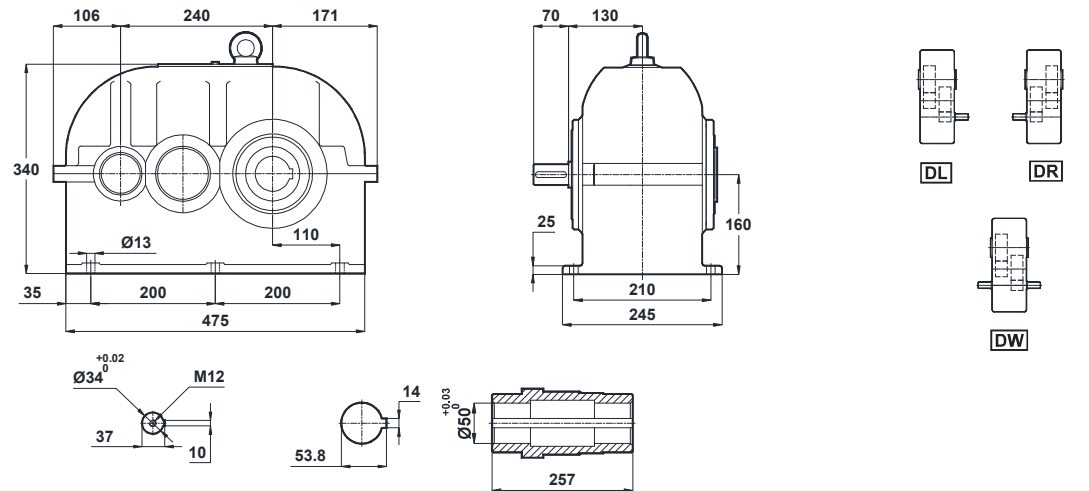





# Ölçü Sayfaları

## Dimension Pages

### Abmessungsseiten



-Mil ucu çekirme deliği DIN 332 sayfa 2 / Tapped center hole according to DIN 332, sheet 2 / Zentrierung mit Gewinde nach DIN 332, Blatt 2

YRM2275. □

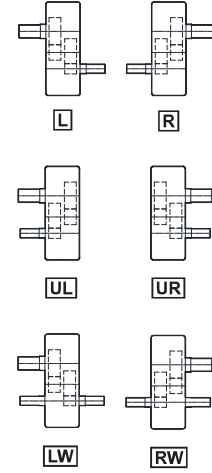
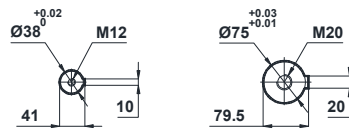
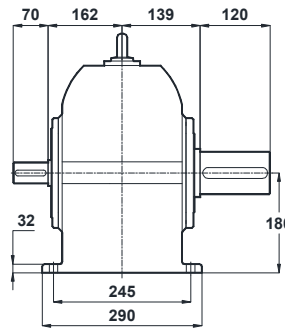
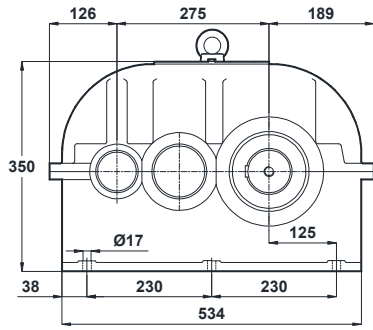

YRC2275. □

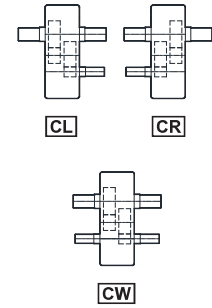
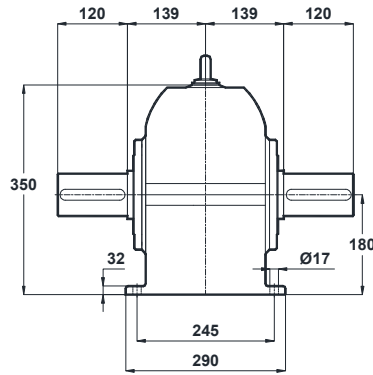
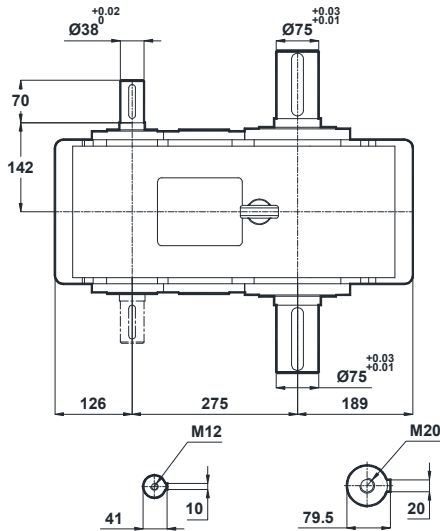

YRD2275. □

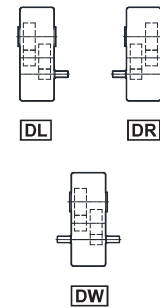
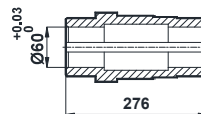
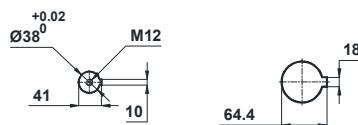
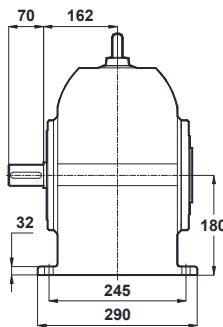
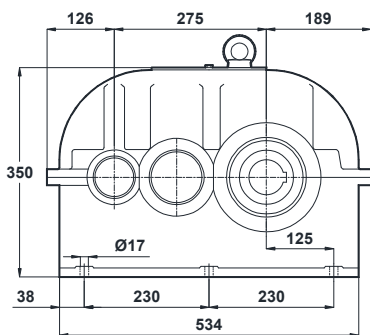



# Ölçü Sayfaları Dimension Pages Abmessungsseiten



-Mil ucu çektirme deliği DIN 332 sayfa 2 / Tapped center hole according to DIN 332, sheet 2 / Zentrierung mit Gewinde nach DIN 332, Blatt 2

YRM2305.□

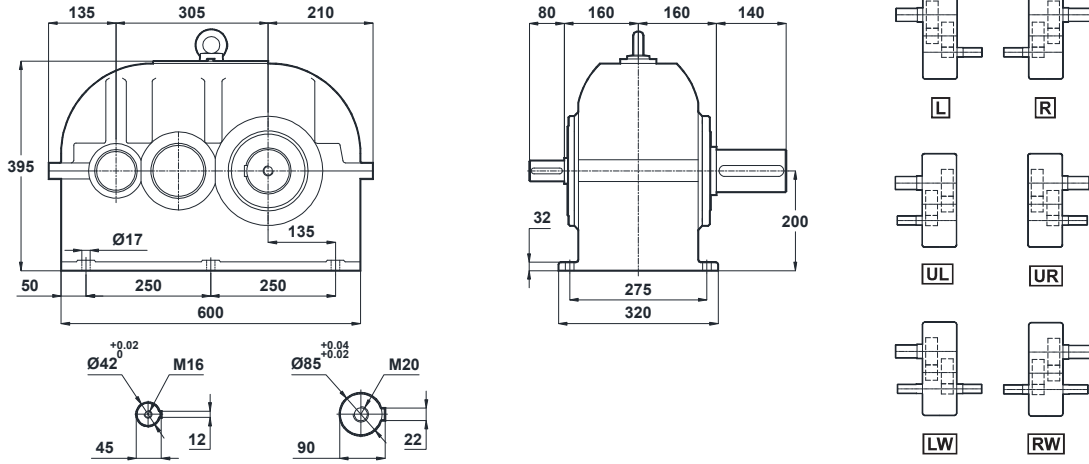

YRC2305.□

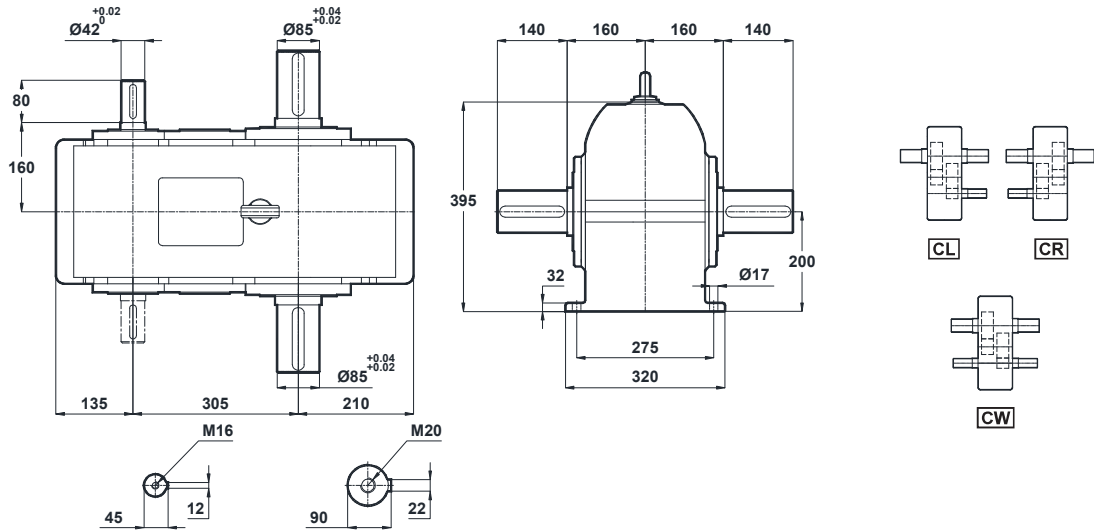

YRD2305.□

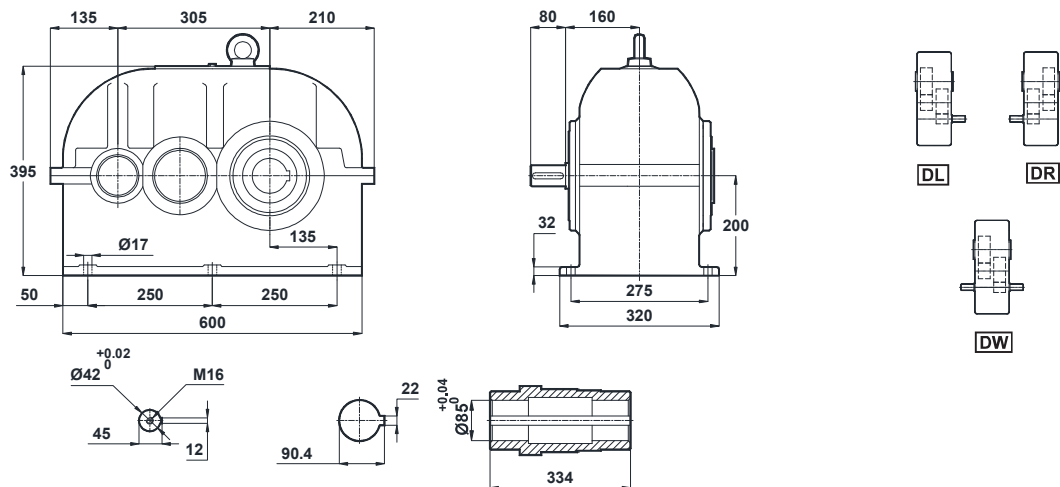



# Ölçü Sayfaları

## Dimension Pages

### Abmessungsseiten



-Mil ucu çekirme deliği DIN 332 sayfa 2 / Tapped center hole according to DIN 332, sheet 2 / Zentrierung mit Gewinde nach DIN 332, Blatt 2

YRM2340.□

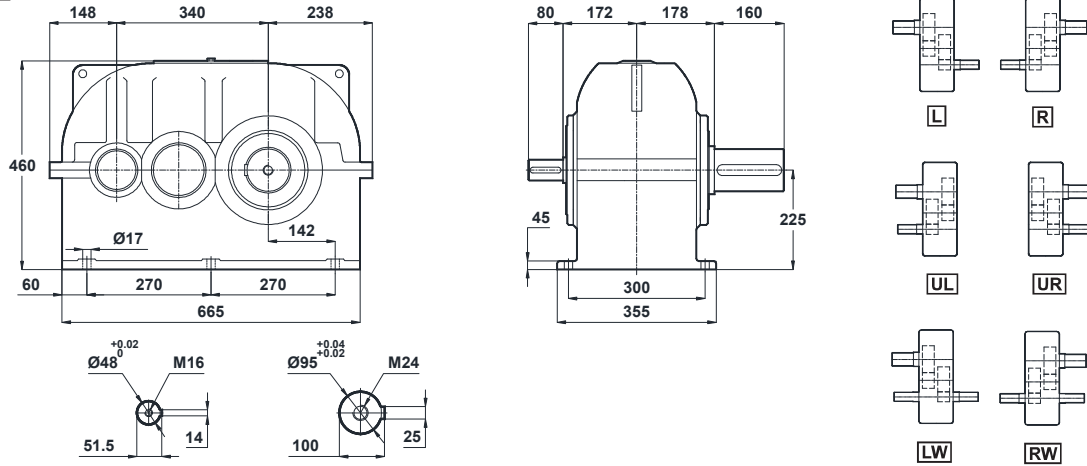

YRC2340.□

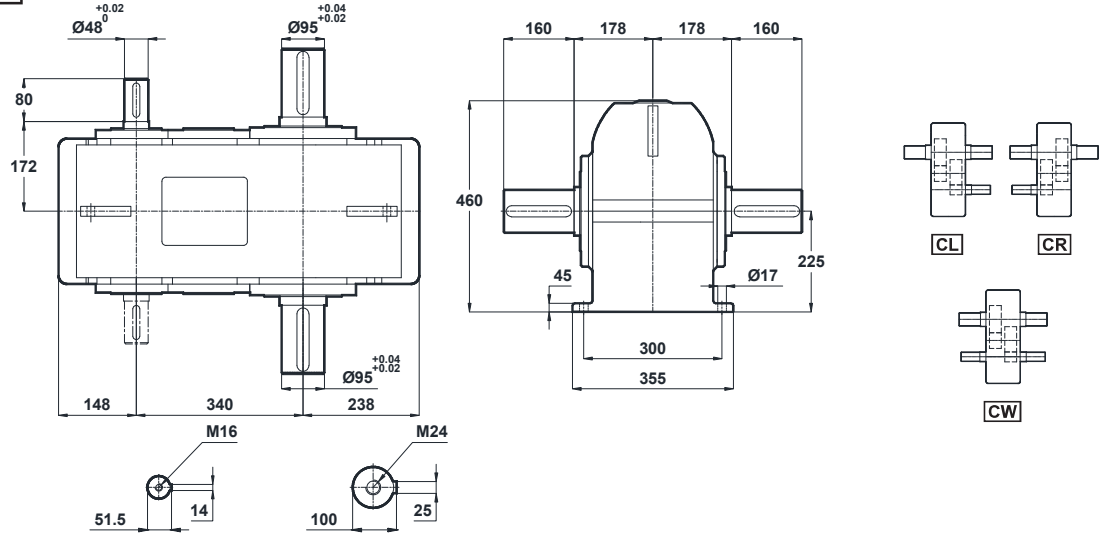

YRD2340.□

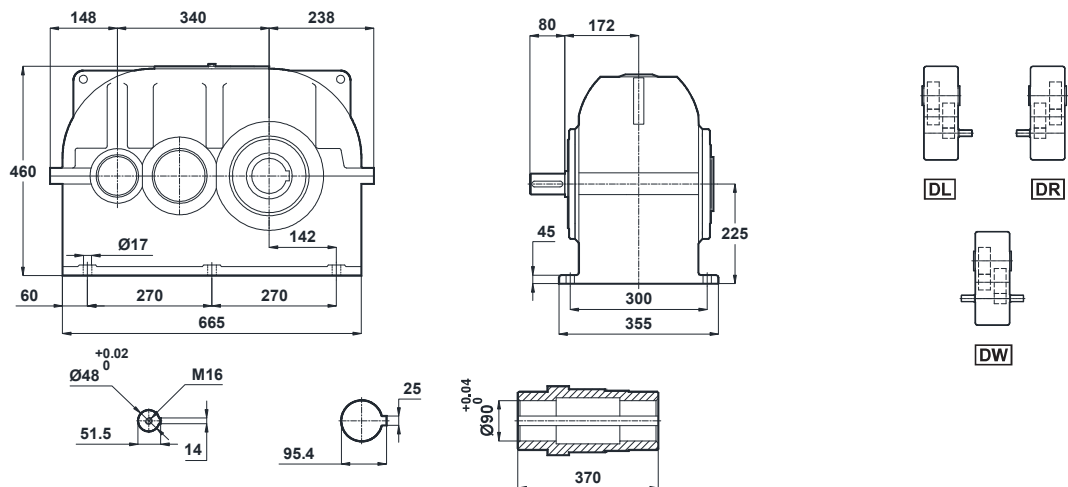



# Ölçü Sayfaları Dimension Pages Abmessungsseiten



-Mil ucu çektirme deliği DIN 332 sayfa 2 / Tapped center hole according to DIN 332, sheet 2 / Zentrierung mit Gewinde nach DIN 332, Blatt 2

YRM2385.□

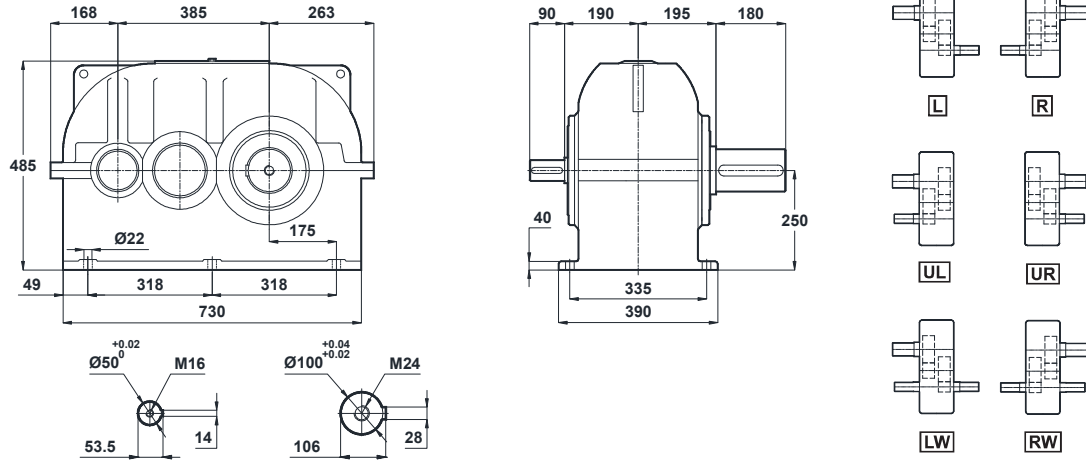

YRC2385.□

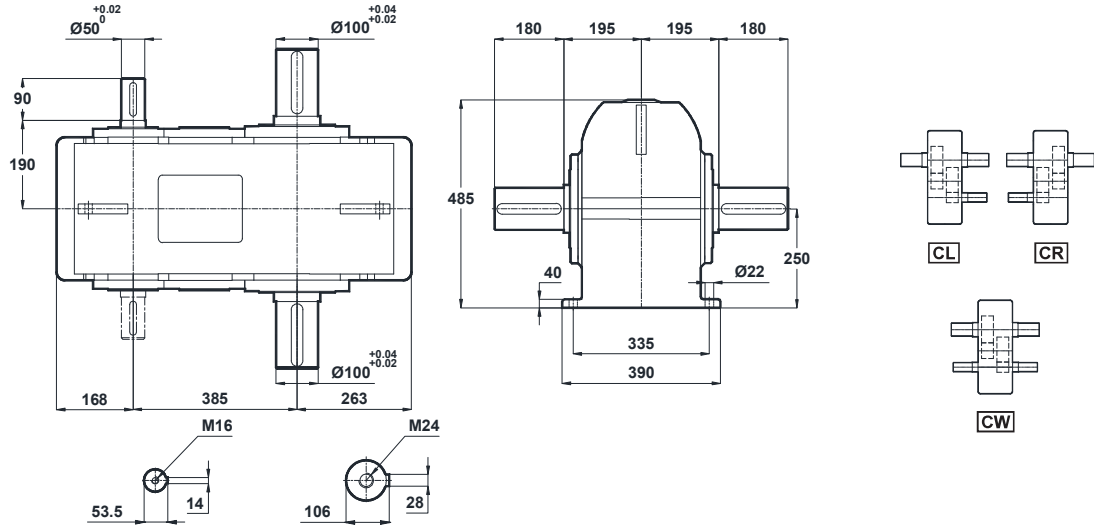

YRD2385.□

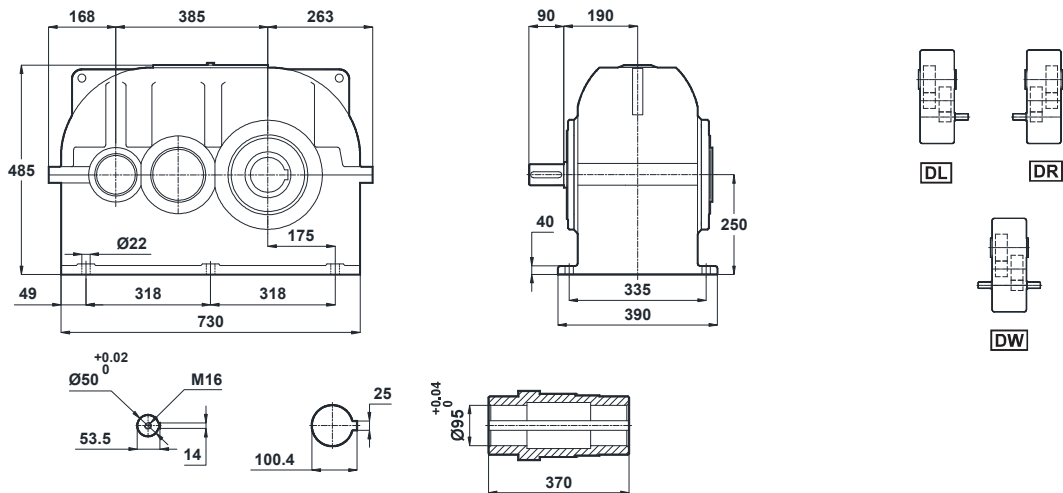



# Ölçü Sayfaları

## Dimension Pages

### Abmessungsseiten



-Mil ucu çekirme deliği DIN 332 sayfa 2 / Tapped center hole according to DIN 332, sheet 2 / Zentrierung mit Gewinde nach DIN 332, Blatt 2

#### YRM2430.□

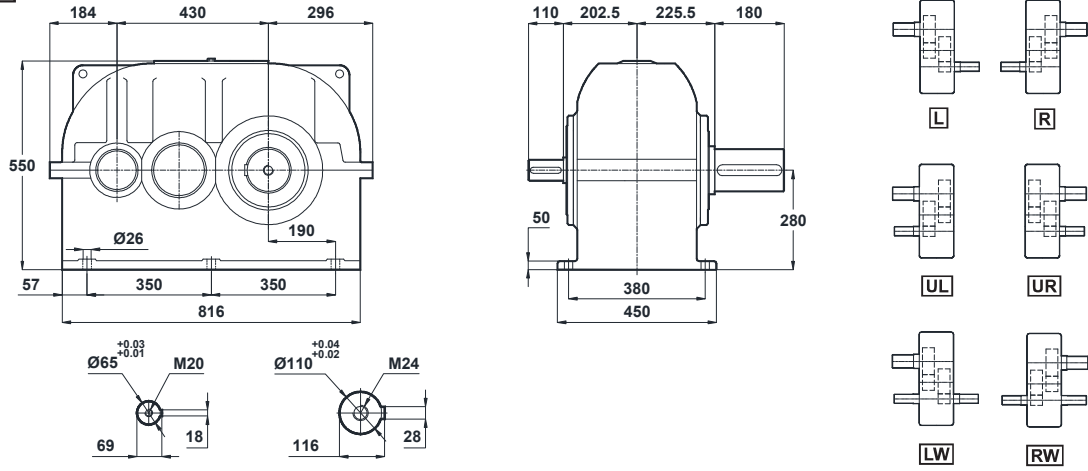

#### YRC2430.□

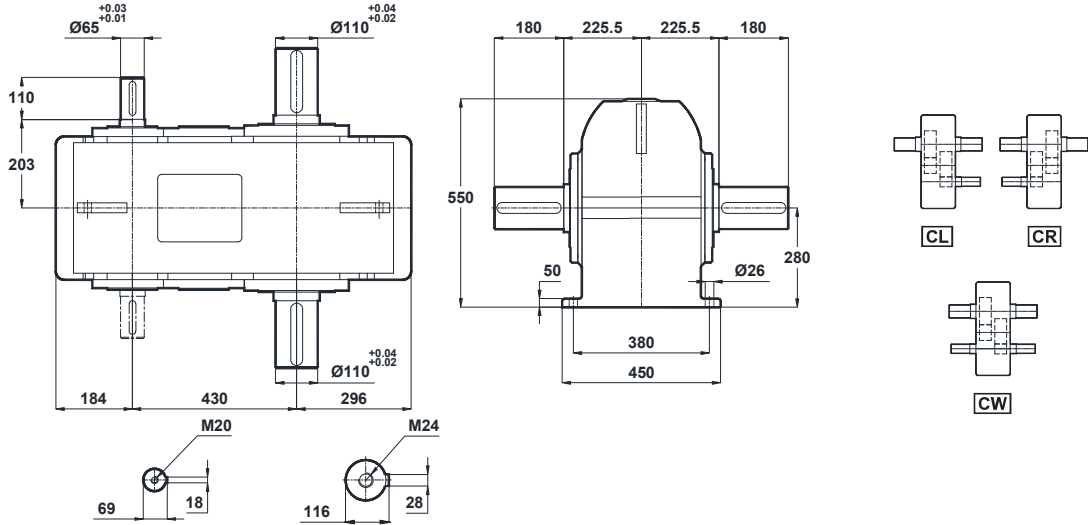

#### YRD2430.□

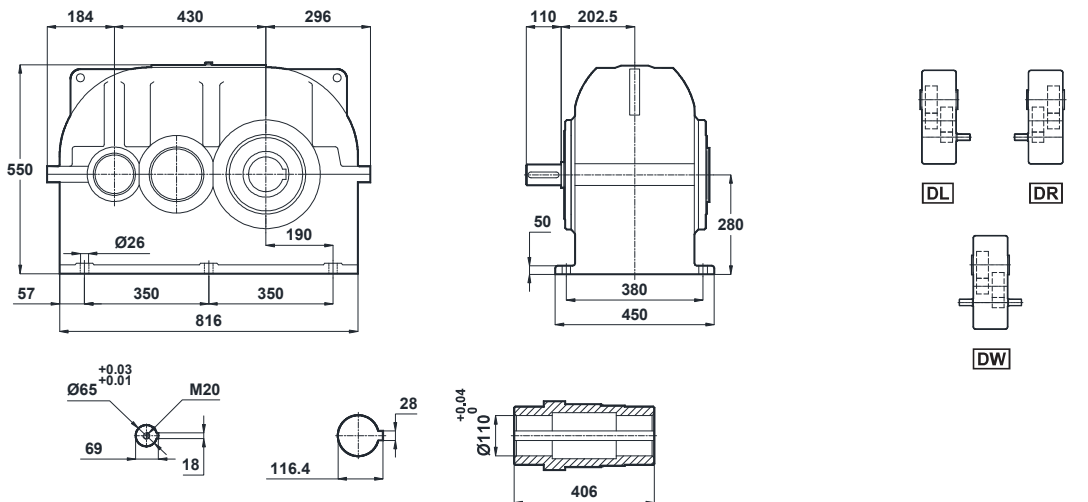





# Ölçü Sayfaları

## Dimension Pages

### Abmessungsseiten



-Mil ucu çektirme deliği DIN 332 sayfa 2 / Tapped center hole according to DIN 332, sheet 2 / Zentrierung mit Gewinde nach DIN 332, Blatt 2

YRM2480.□

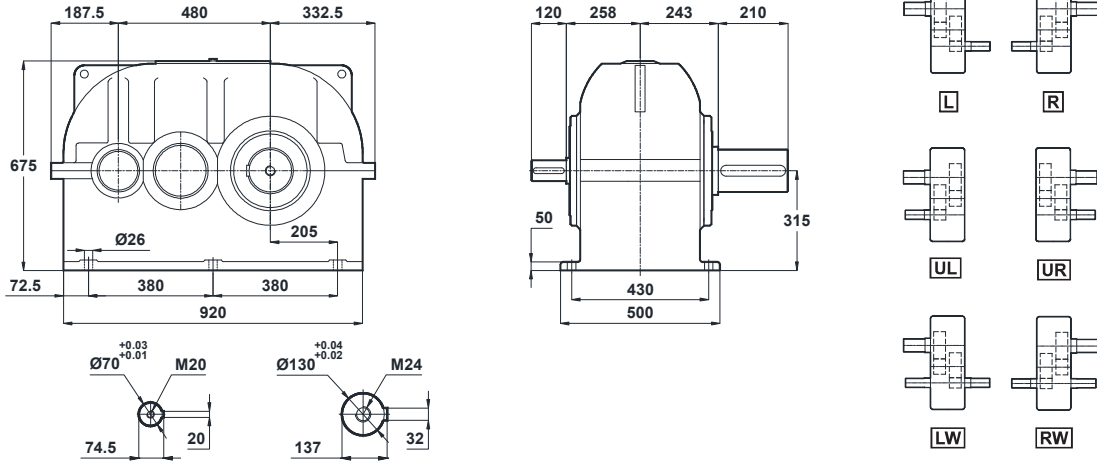

YRC2480.□

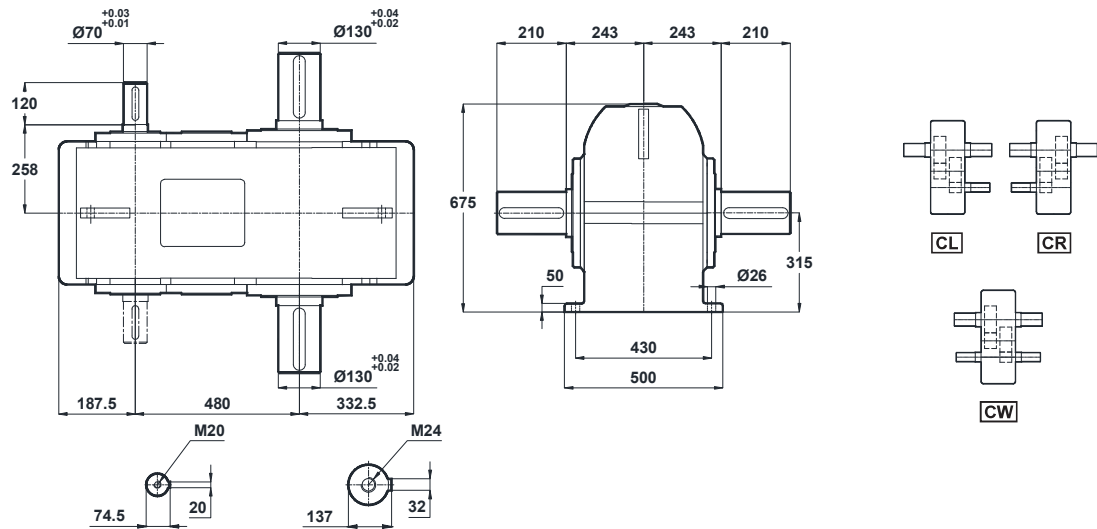

YRD2480.□

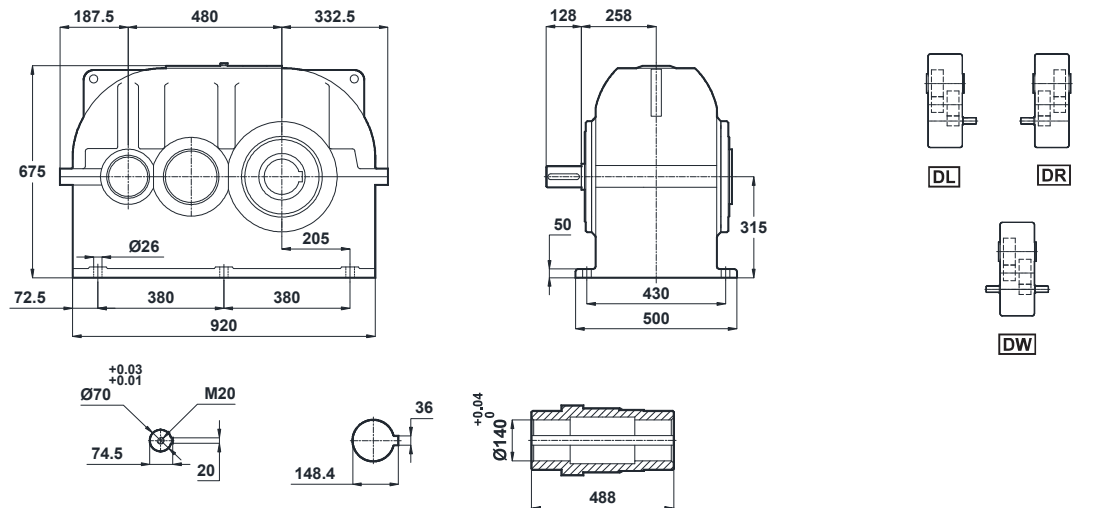



# Ölçü Sayfaları

## Dimension Pages

### Abmessungsseiten



-Mil ucu çekirme deliği DIN 332 sayfa 2 / Tapped center hole according to DIN 332, sheet 2 / Zentrierung mit Gewinde nach DIN 332, Blatt 2

YRM2545.□

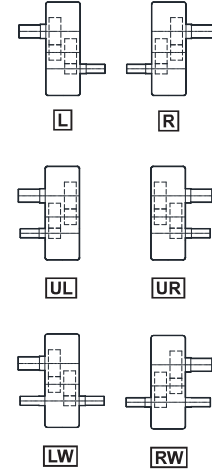
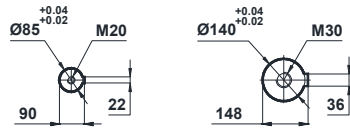
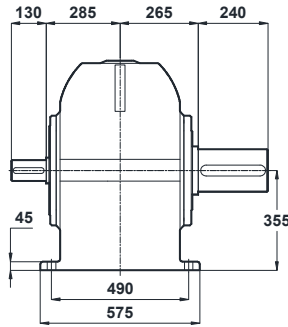
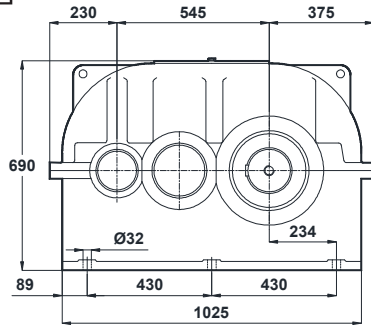

YRC2545.□

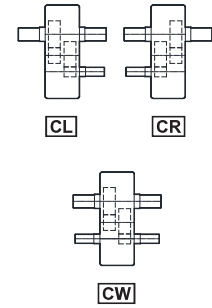
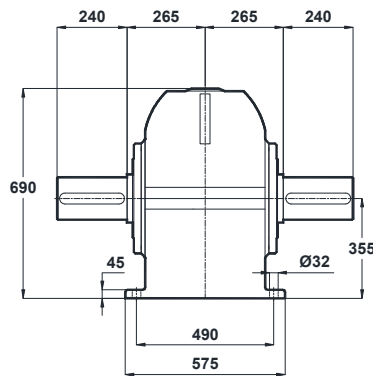
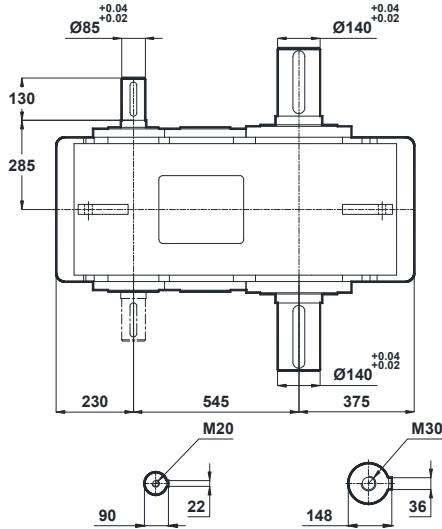

YRD2545.□

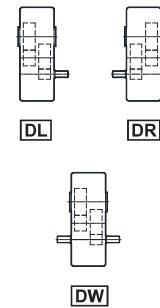
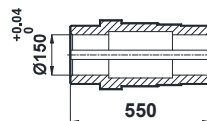
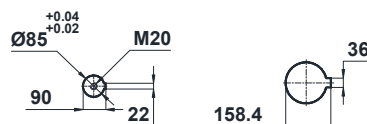
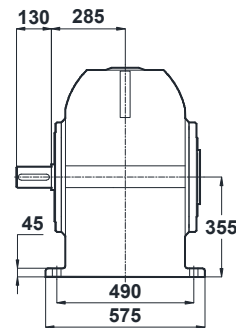
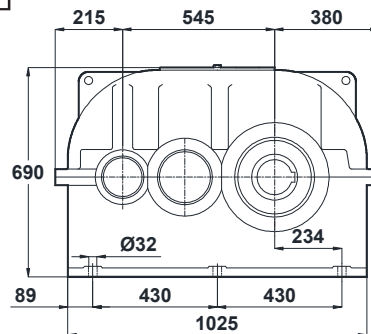



# Ölçü Sayfaları

## Dimension Pages

### Abmessungsseiten



-Mil ucu çektirme deliği DIN 332 sayfa 2 / Tapped center hole according to DIN 332, sheet 2 / Zentrierung mit Gewinde nach DIN 332, Blatt 2

YRM3355.□

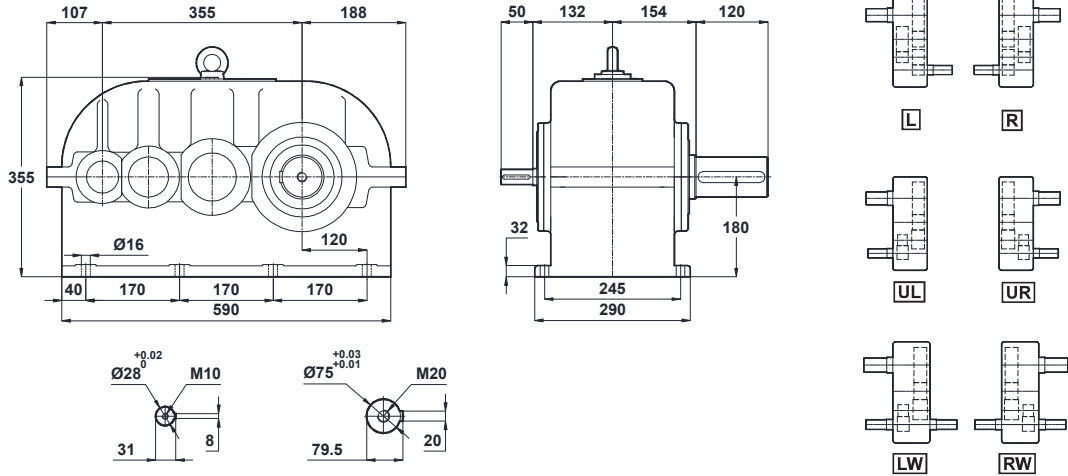

YRC3355.□

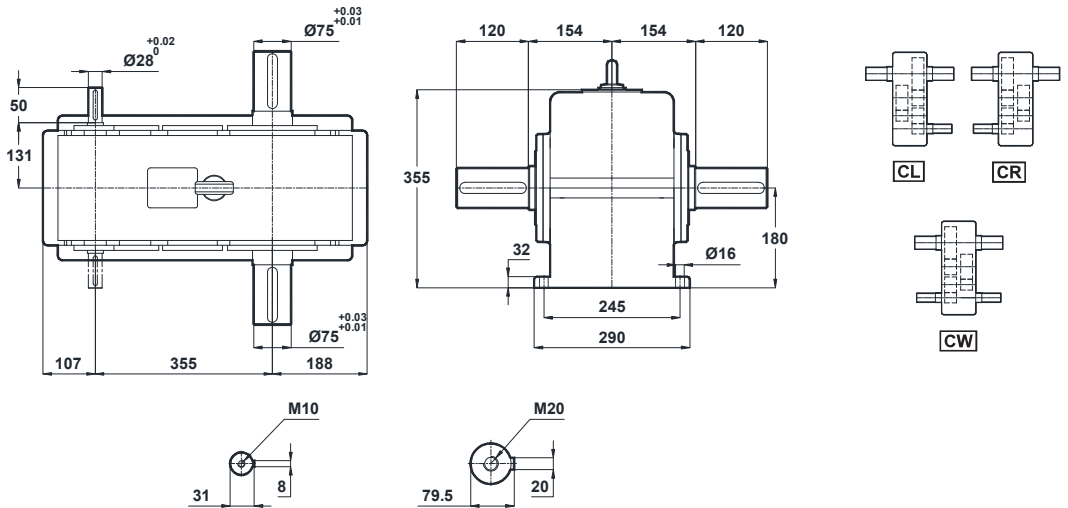

YRD3355.□

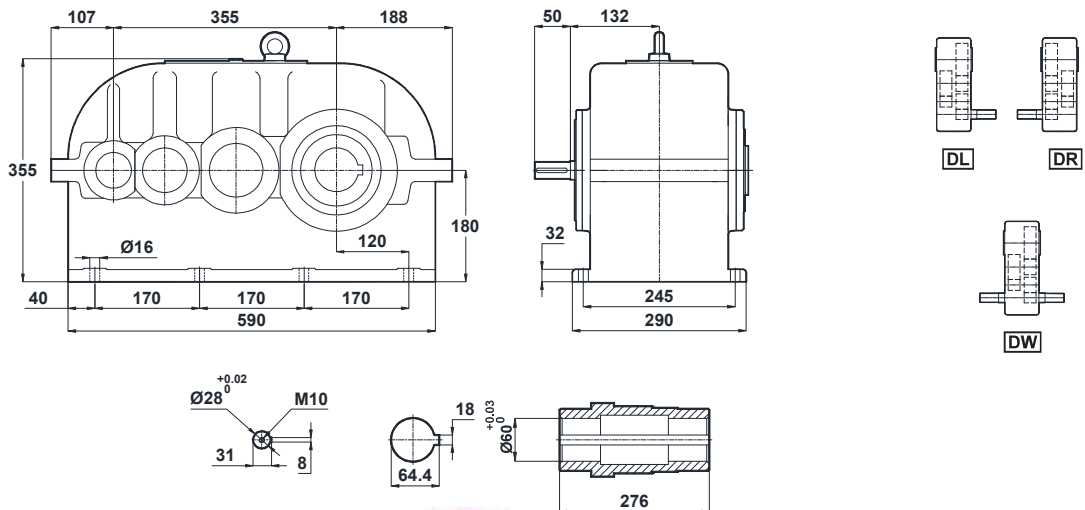



# Ölçü Sayfaları

## Dimension Pages

### Abmessungsseiten



-Mil ucu çekirme deliği DIN 332 sayfa 2 / Tapped center hole according to DIN 332, sheet 2 / Zentrierung mit Gewinde nach DIN 332, Blatt 2

YRM3395.□

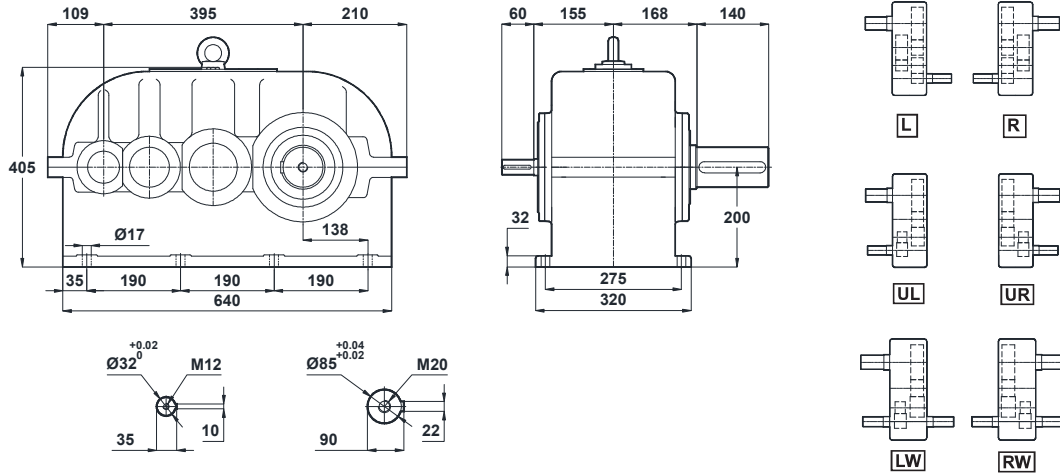

YRC3395.□

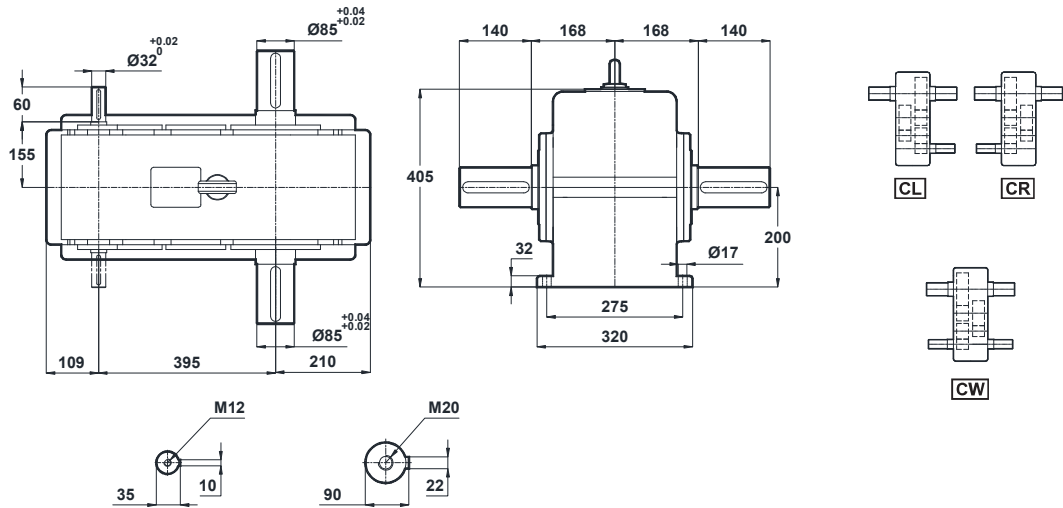

YRD3395.□

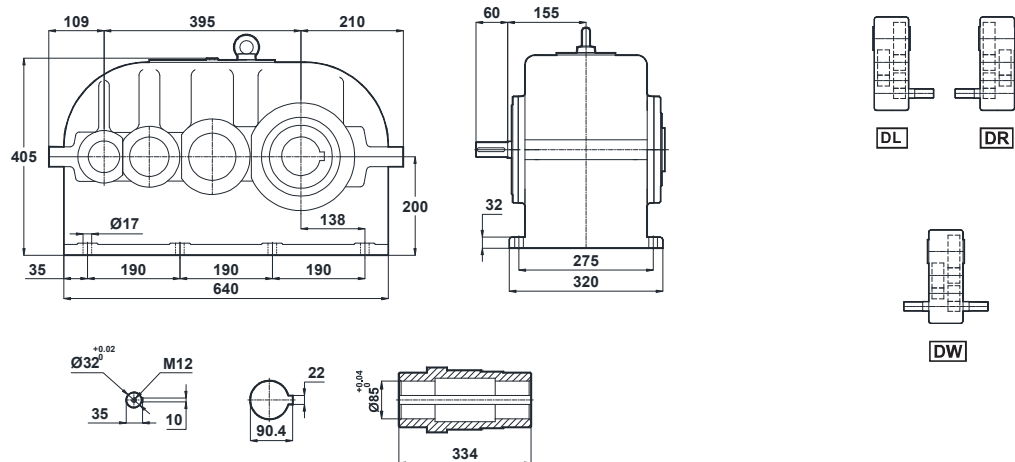



# Ölçü Sayfaları Dimension Pages Abmessungsseiten



-Mil ucu çekirme deliği DIN 332 sayfa 2 / Tapped center hole according to DIN 332, sheet 2 / Zentrierung mit Gewinde nach DIN 332, Blatt 2

YRM3440.□

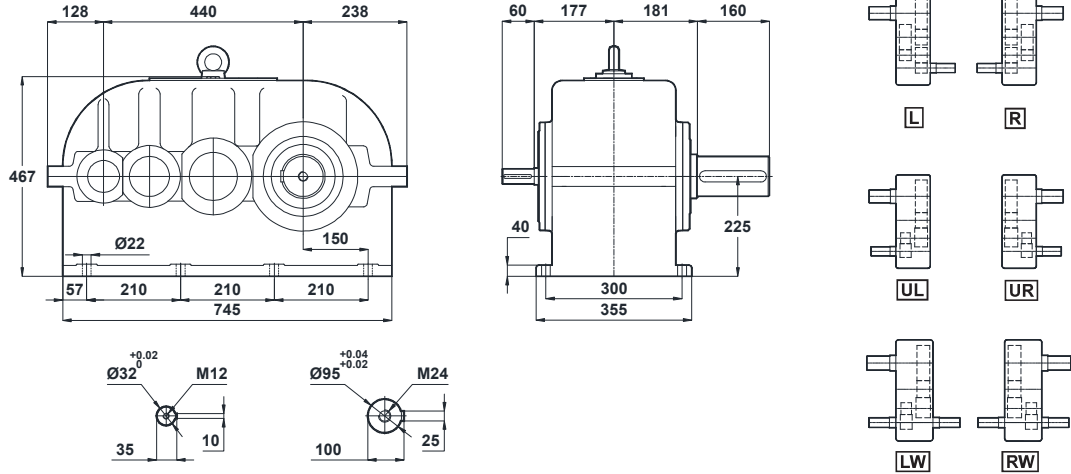

YRC3440.□

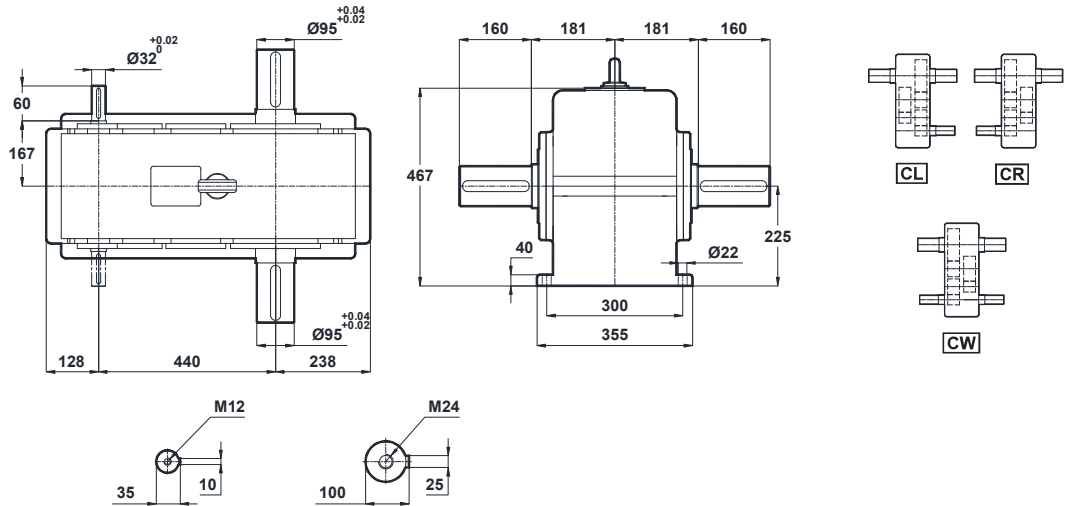

YRD3440.□

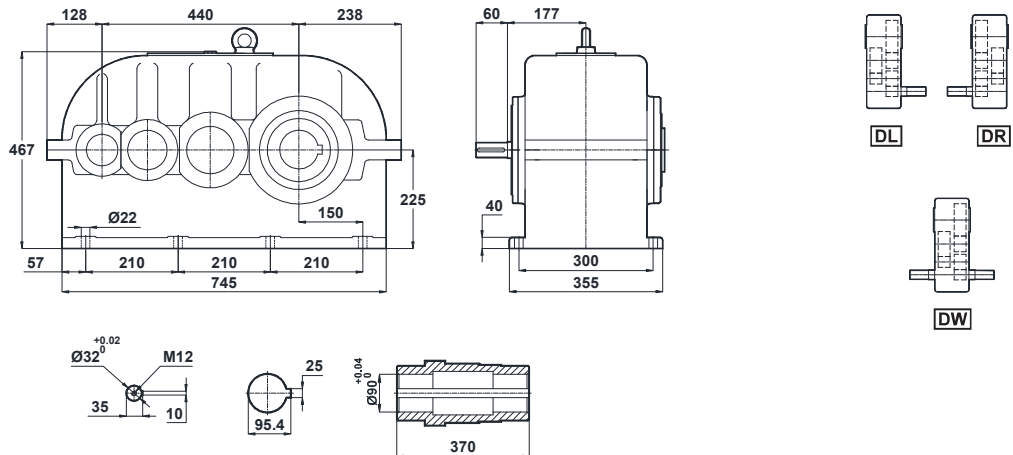





# Ölçü Sayfaları

## Dimension Pages

### Abmessungsseiten



-Mil ucu çekirme deliği DIN 332 sayfa 2 / Tapped center hole according to DIN 332, sheet 2 / Zentrierung mit Gewinde nach DIN 332, Blatt 2

YRM3500.□

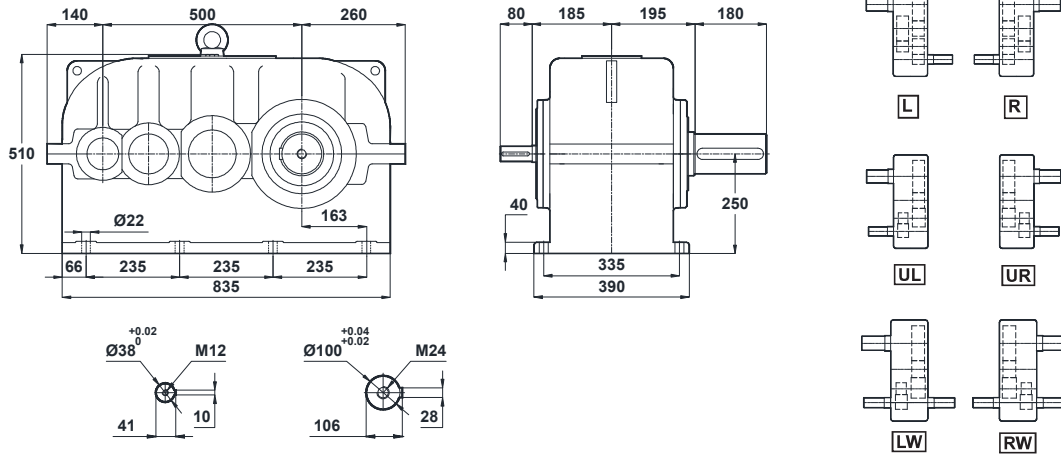

YRC3500.□

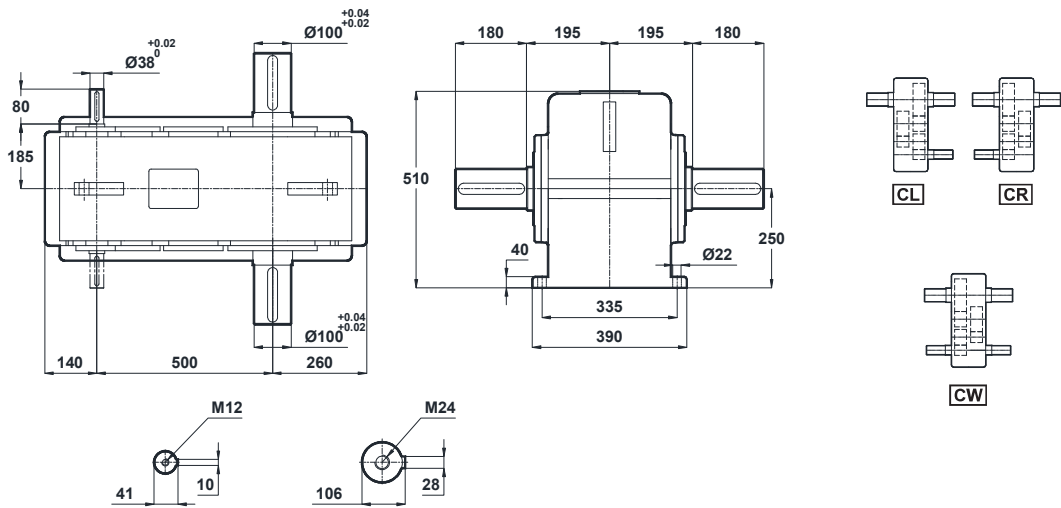

YRD3500.□

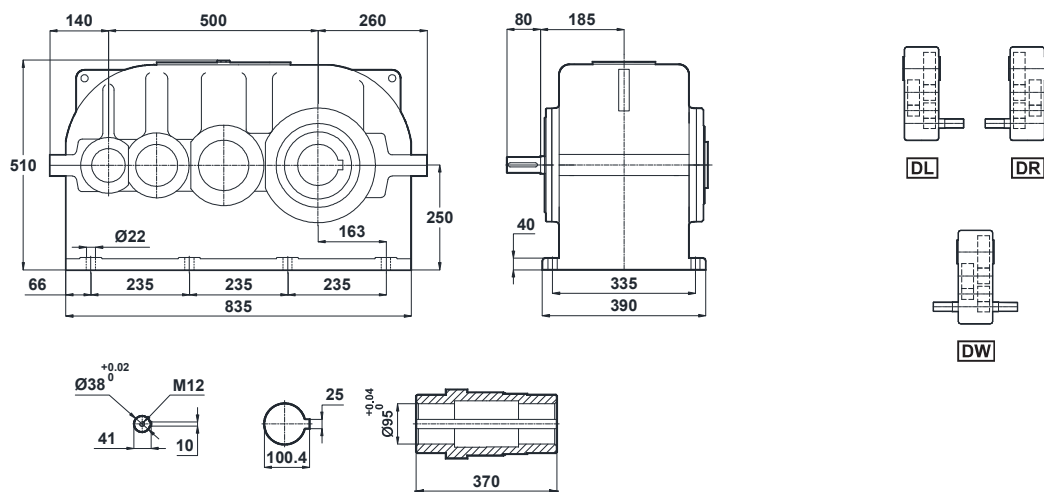



# Ölçü Sayfaları Dimension Pages Abmessungsseiten



-Mil ucu çektirme deliği DIN 332 sayfa 2 / Tapped center hole according to DIN 332, sheet 2 / Zentrierung mit Gewinde nach DIN 332, Blatt 2

YRM3555.□

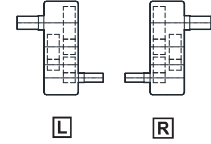
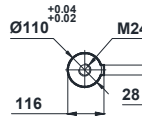
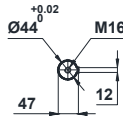
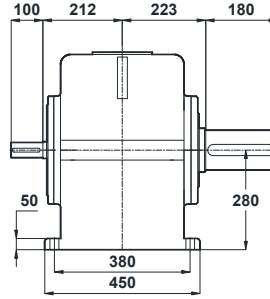
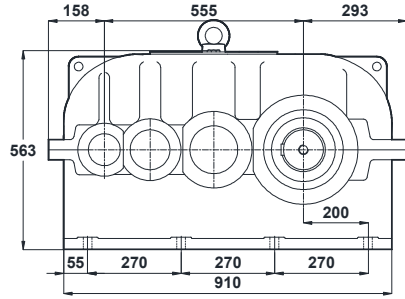

L

R

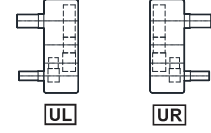

UL

UR

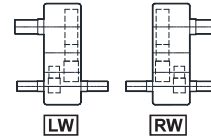

LW

RW

YRC3555.□

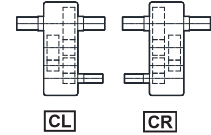
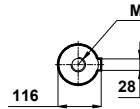
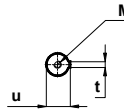
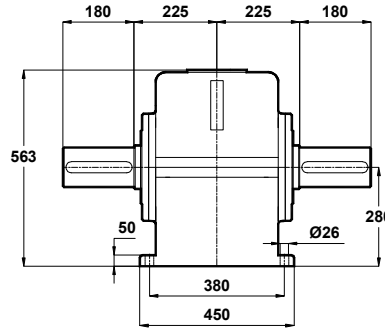
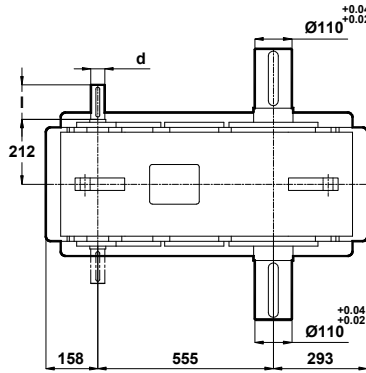

CL

CR

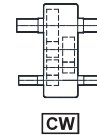

CW

YRD3555.□

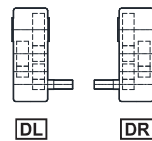
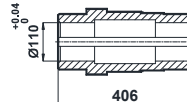
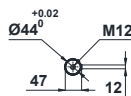
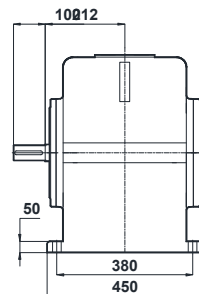
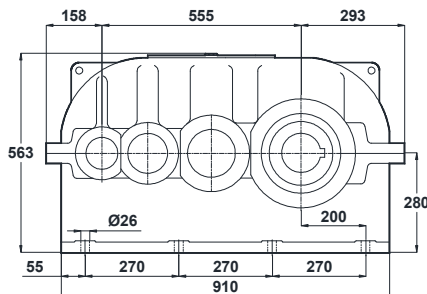

DL

DR

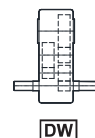

DW

Çift giriş millerinde çap ölçüsü farklı olabilir. Yılmaz Redüktöre danışınız. / Diameter of double input shafts can be different between each other. Please consult us. / Die Dimensionen von Doppelabtriebswellen können unterschiedlich sein. Fragen Sie uns



# Ölçü Sayfaları

## Dimension Pages

### Abmessungsseiten



-Mil ucu çekirme deliği DIN 332 sayfa 2 / Tapped center hole according to DIN 332, sheet 2 / Zentrierung mit Gewinde nach DIN 332, Blatt 2

YRM3620.□

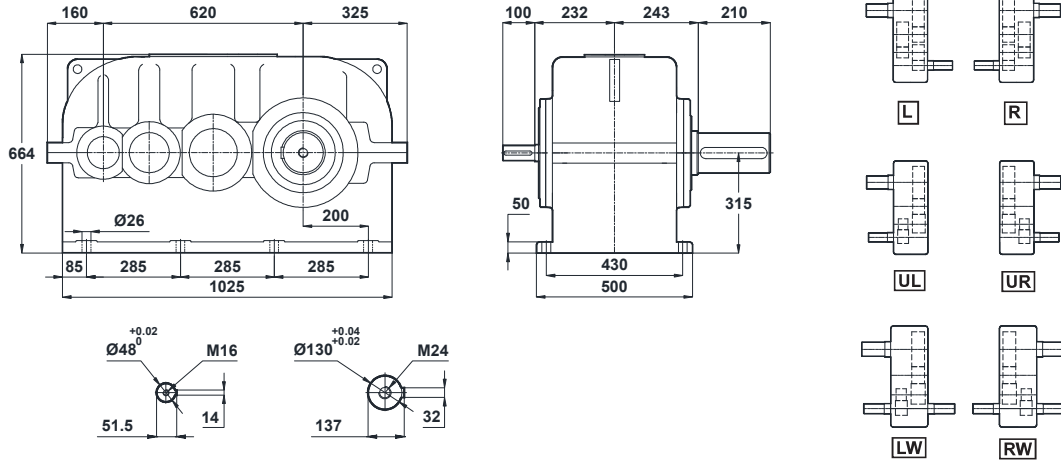

YRC3620.□

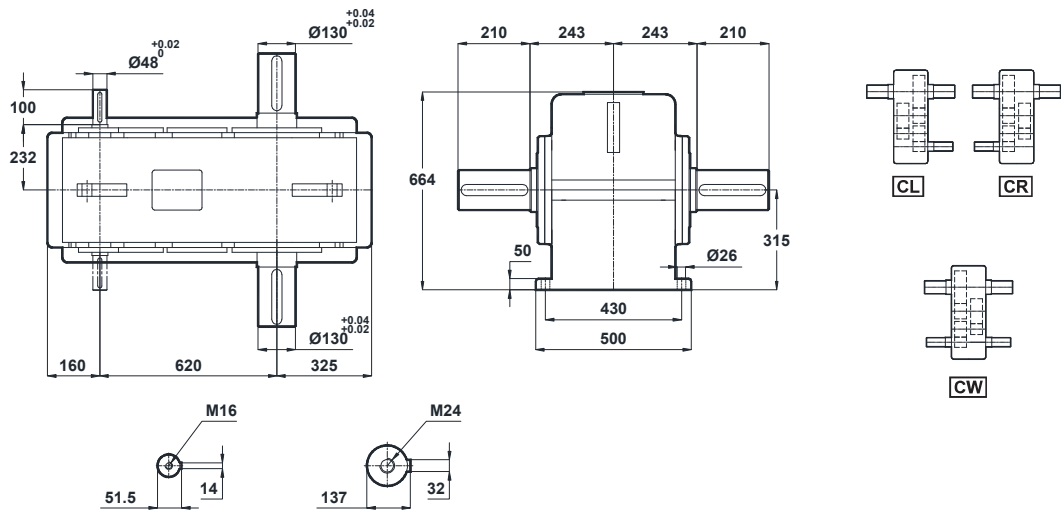

YRD3620.□

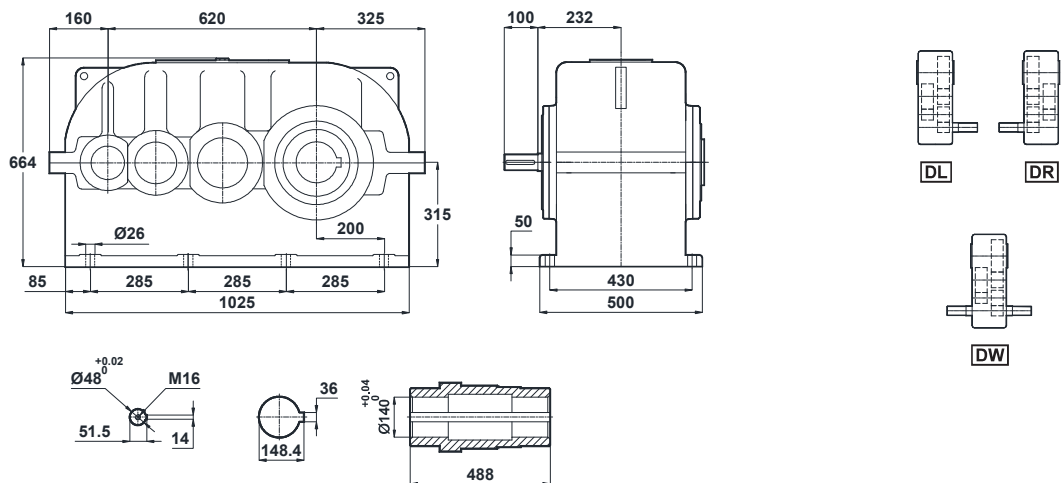



# Ölçü Sayfaları Dimension Pages Abmessungsseiten



-Mil ucu çekirme deliği DIN 332 sayfa 2 / Tapped center hole according to DIN 332, sheet 2 / Zentrierung mit Gewinde nach DIN 332, Blatt 2

YRM3705.□

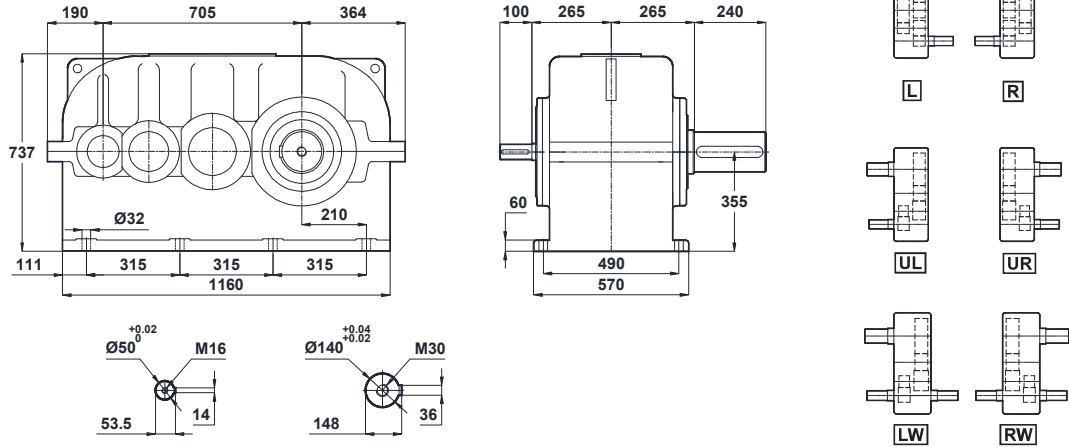

YRC3705.□

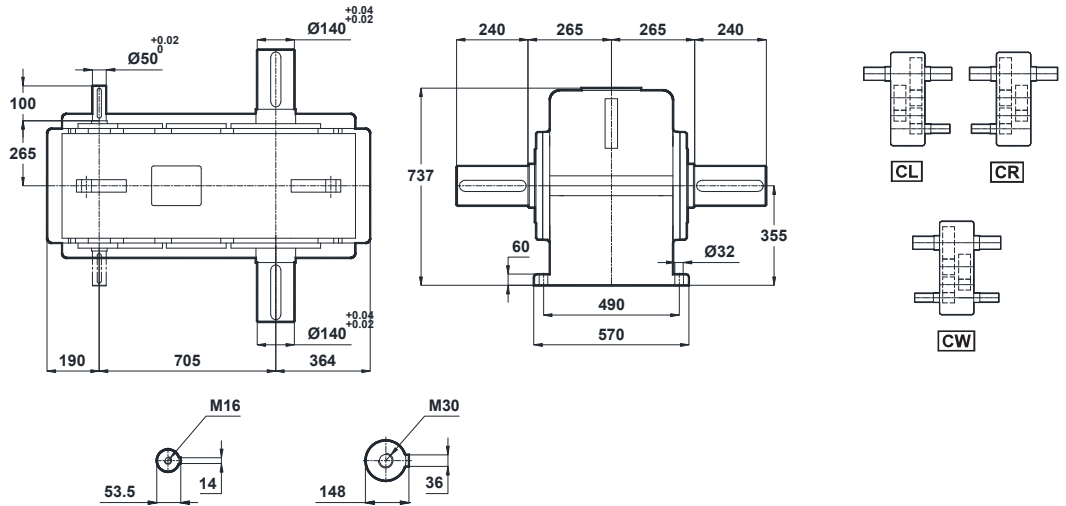

YRD3705.□

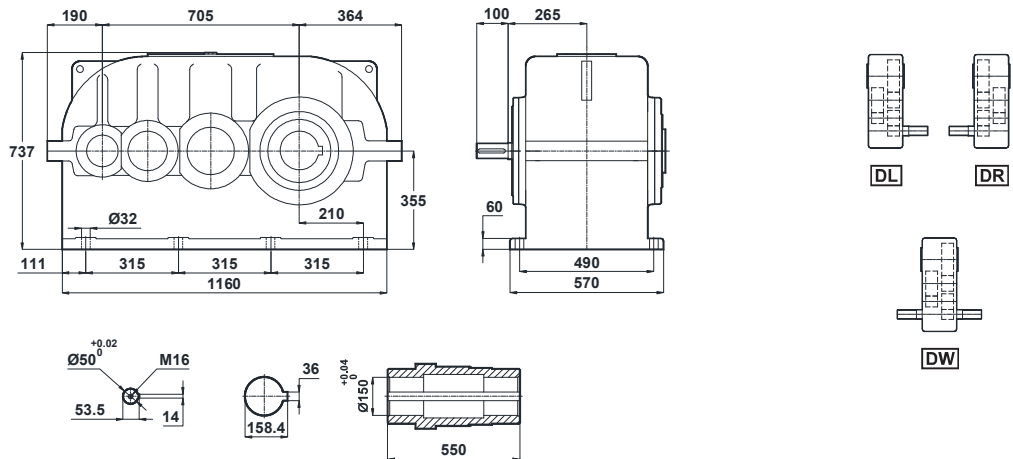



# Ölçü Sayfaları

## Dimension Pages

### Abmessungsseiten



-Mil ucu çekirme deliği DIN 332 sayfa 2 / Tapped center hole according to DIN 332, sheet 2 / Zentrierung mit Gewinde nach DIN 332, Blatt 2

YRM4395.□

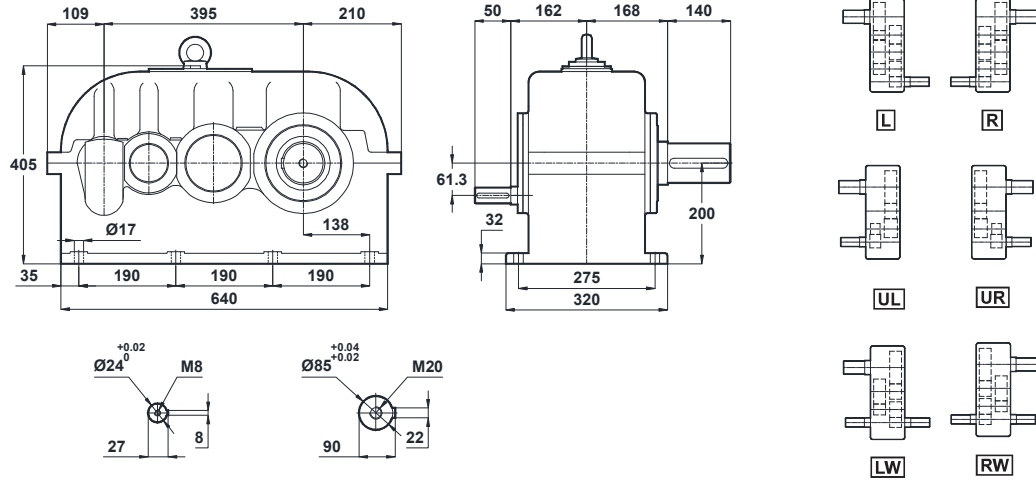

YRC4395.□

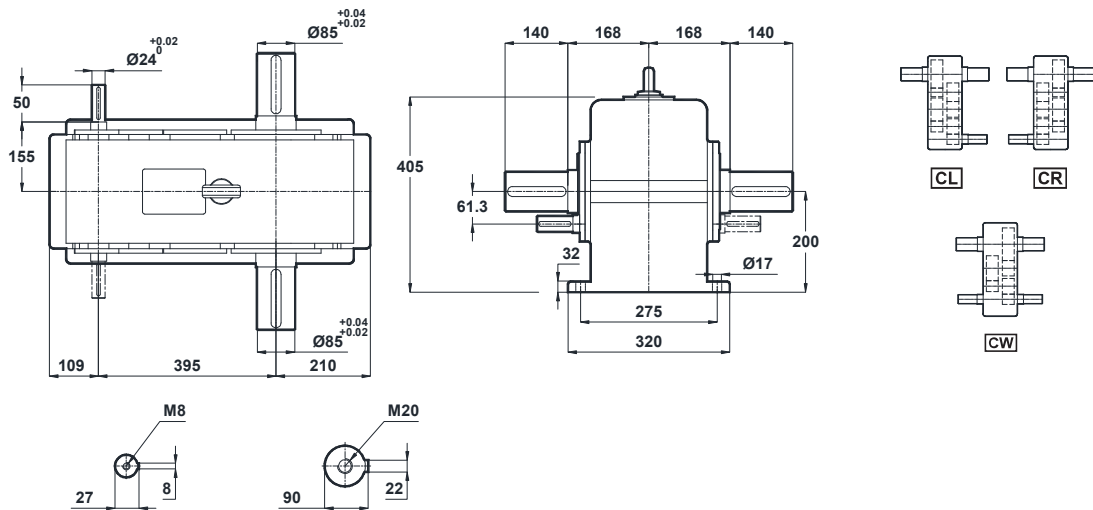

YRD4395.□

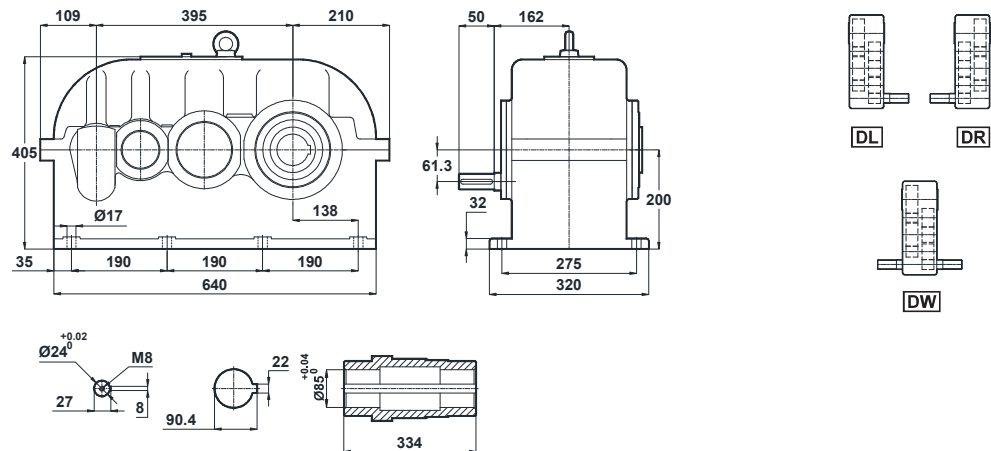



# Ölçü Sayfaları

## Dimension Pages

### Abmessungsseiten



-Mil ucu çektirme deliği DIN 332 sayfa 2 / Tapped center hole according to DIN 332, sheet 2 / Zentrierung mit Gewinde nach DIN 332, Blatt 2

YRM4440.□

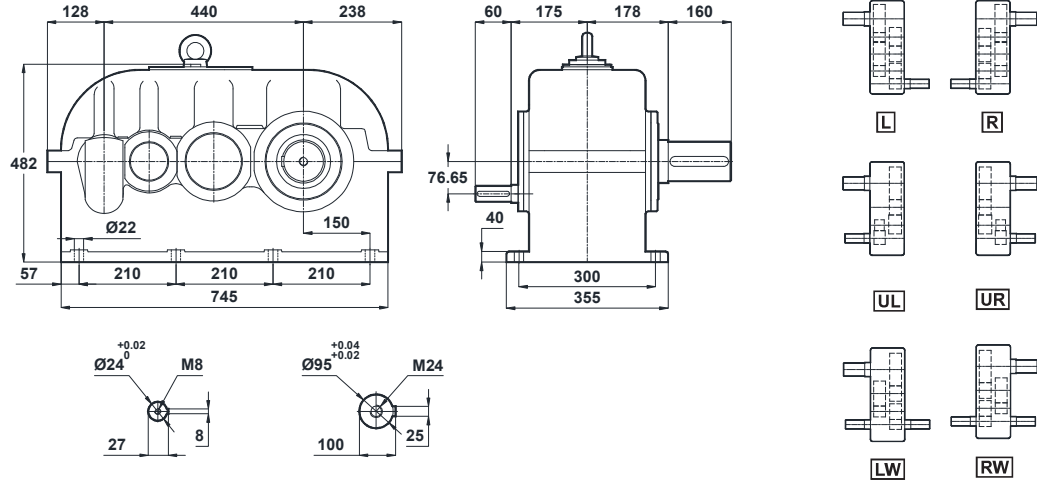

YRC4440.□

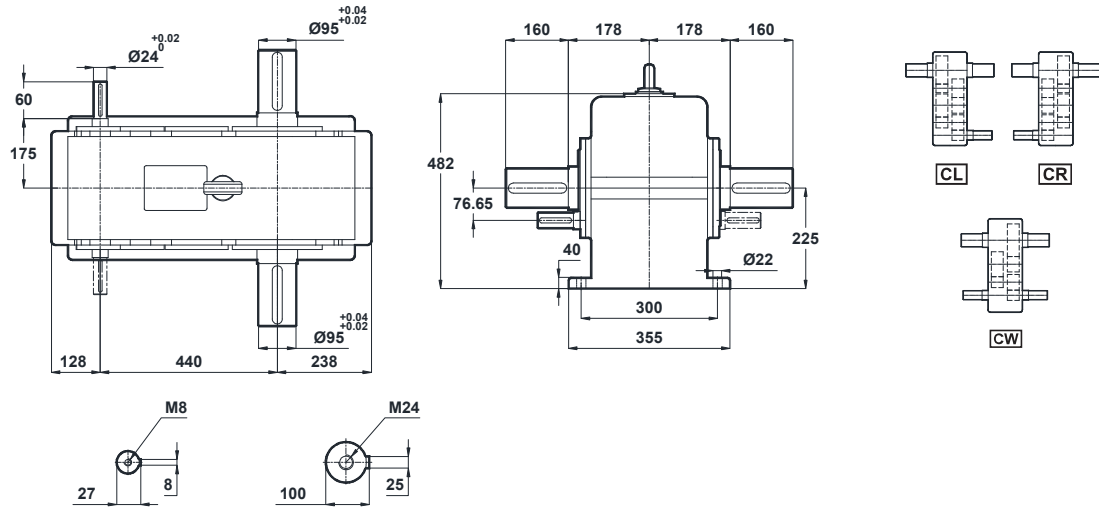

YRD4440.□

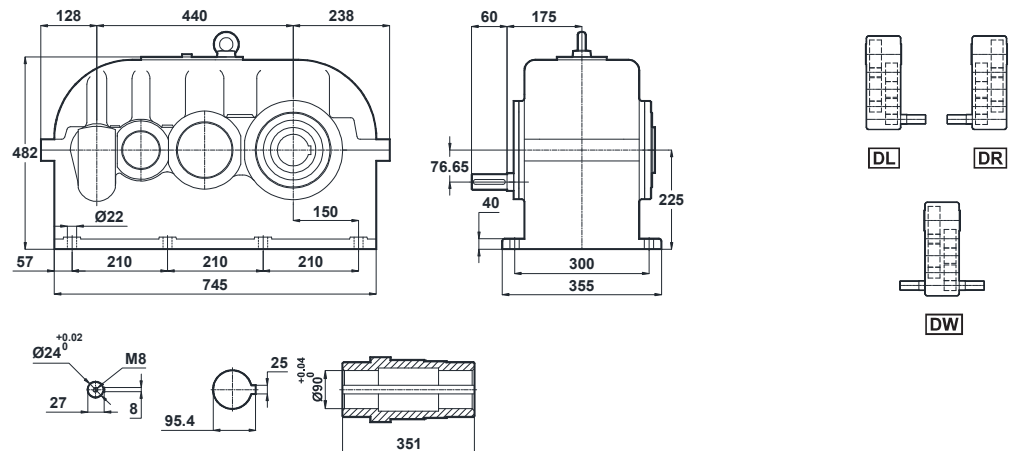







# Ölçü Sayfaları Dimension Pages Abmessungsseiten



-Mil ucu çektirme deliği DIN 332 sayfa 2 / Tapped center hole according to DIN 332, sheet 2 / Zentrierung mit Gewinde nach DIN 332, Blatt 2

YRM4555.□

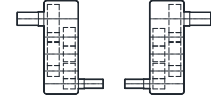
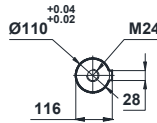
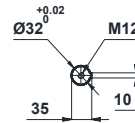
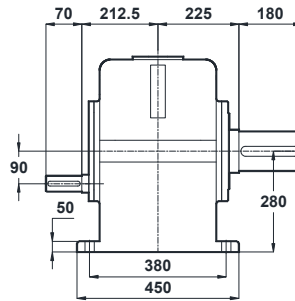
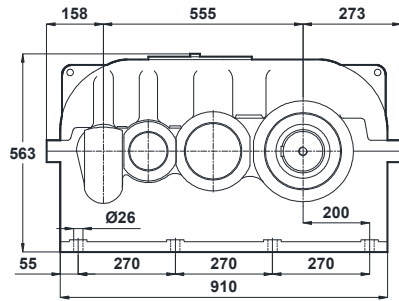

L

R



UL

UR

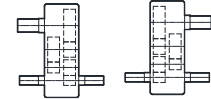

LW

RW

YRC4555.□

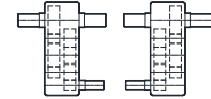
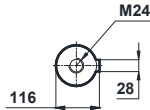
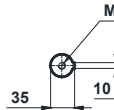
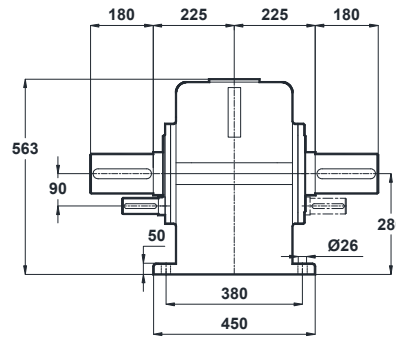
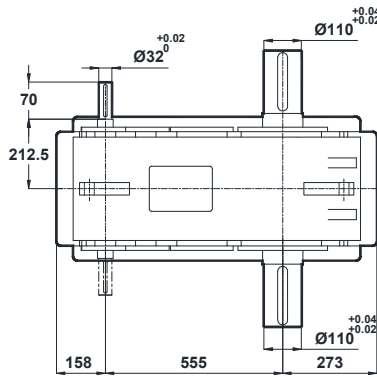

CL

CR



CW

YRD4555.□

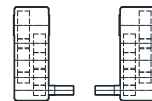
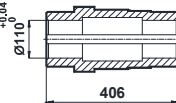
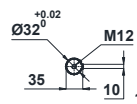
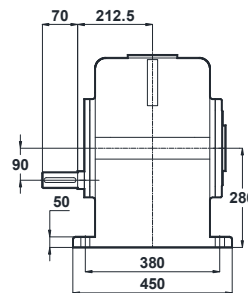
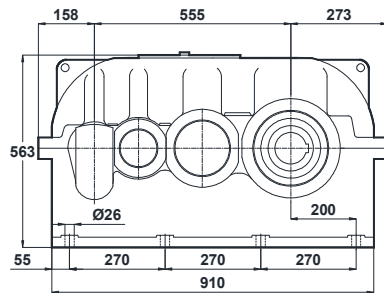

DL

DR



DW



# Ölçü Sayfaları

## Dimension Pages

### Abmessungsseiten



-Mil ucu çekirme deliği DIN 332 sayfa 2 / Tapped center hole according to DIN 332, sheet 2 / Zentrierung mit Gewinde nach DIN 332, Blatt 2

YRM4620.□

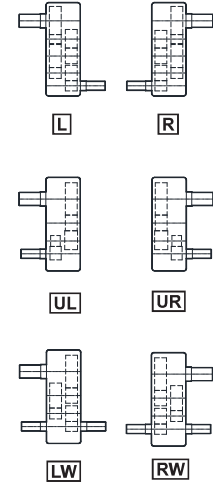
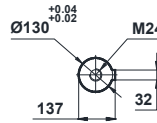
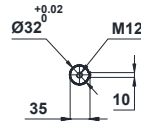
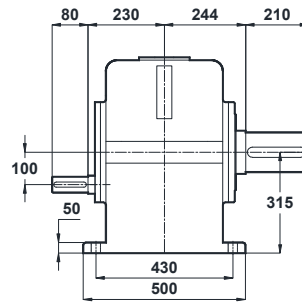
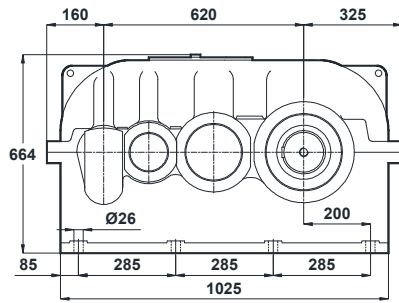

YRC4620.□

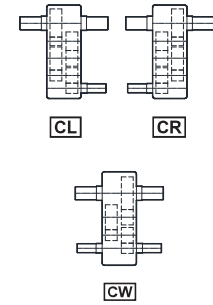
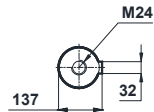
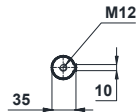
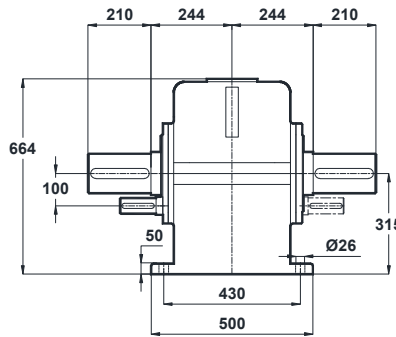
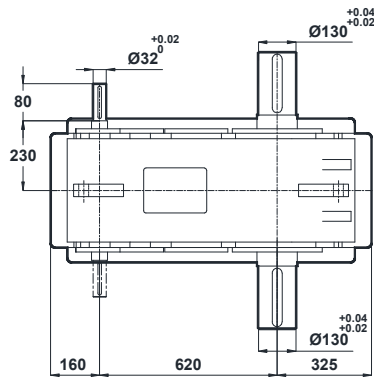

YRD4620.□

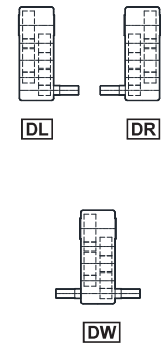
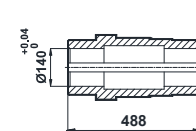
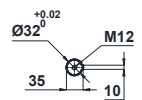
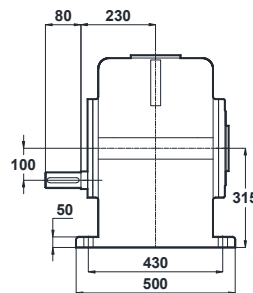
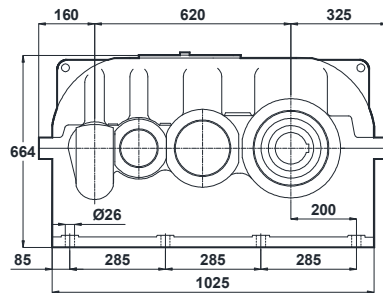



# Ölçü Sayfaları Dimension Pages Abmessungsseiten



-Mil ucu çektirme deliği DIN 332 sayfa 2 / Tapped center hole according to DIN 332, sheet 2 / Zentrierung mit Gewinde nach DIN 332, Blatt 2

YRM4705.□

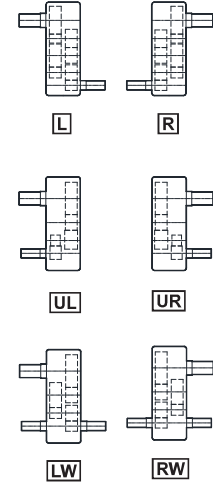
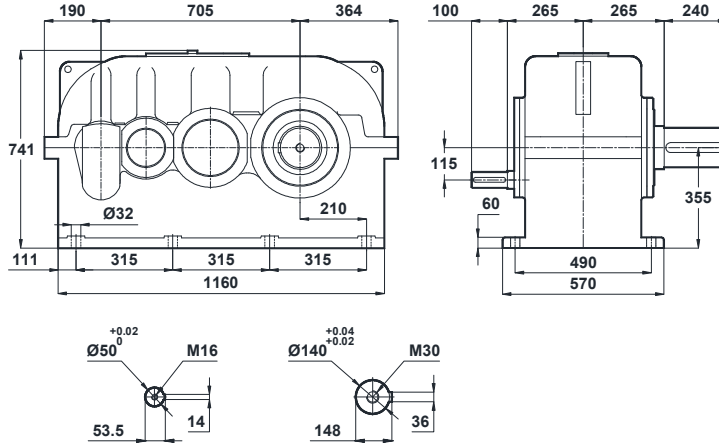

YRC4705.□

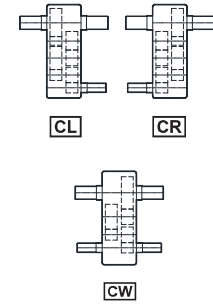
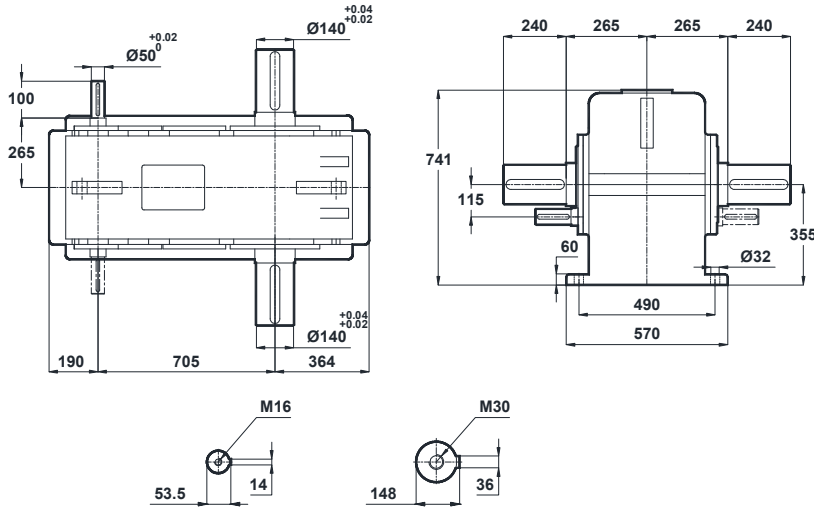

YRD4705.□

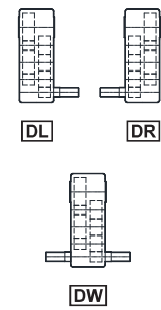
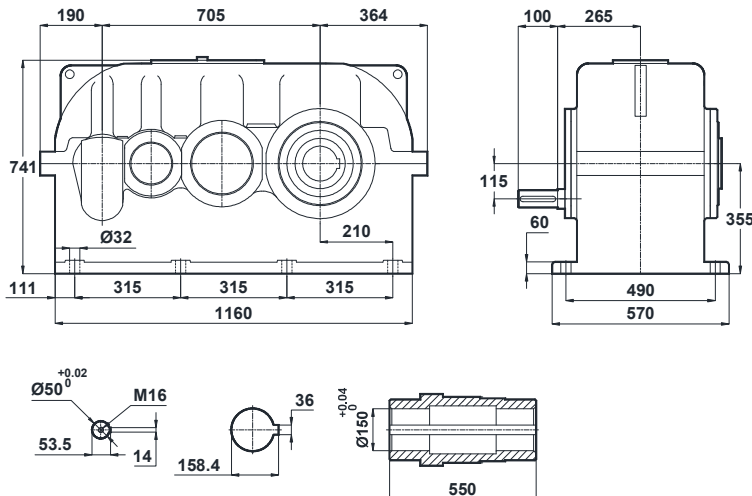

Çift giriş millerinde çap ölçüsü farklı olabilir. Yılmaz Redüktöre danışınız. / Diameter of double input shafts can be different between each other. Please consult us. / Die Dimensionen von Doppelabtriebswellen können unterschiedlich sein. Fragen Sie uns



# Ölçü Sayfaları

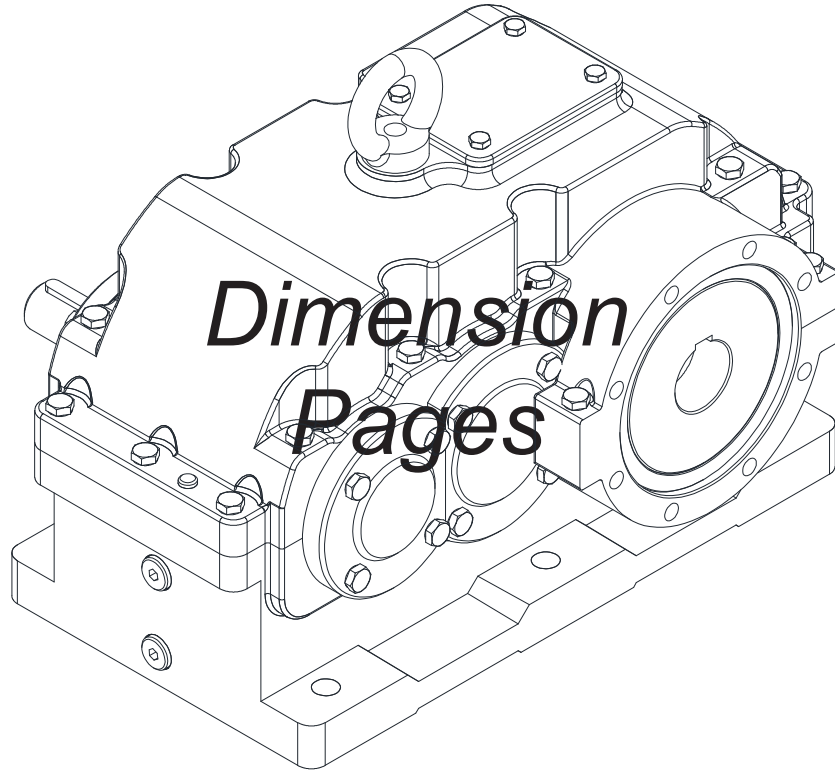

# Abmessungs- seiten



# Ölçü Sayfaları

## Dimension Pages

### Abmessungsseiten



-Mil ucu çekirtme deliği DIN 332 sayfa 2 / Tapped center hole according to DIN 332, sheet 2 / Zentrierung mit Gewinde nach DIN 332, Blatt 2

YRE2240.□

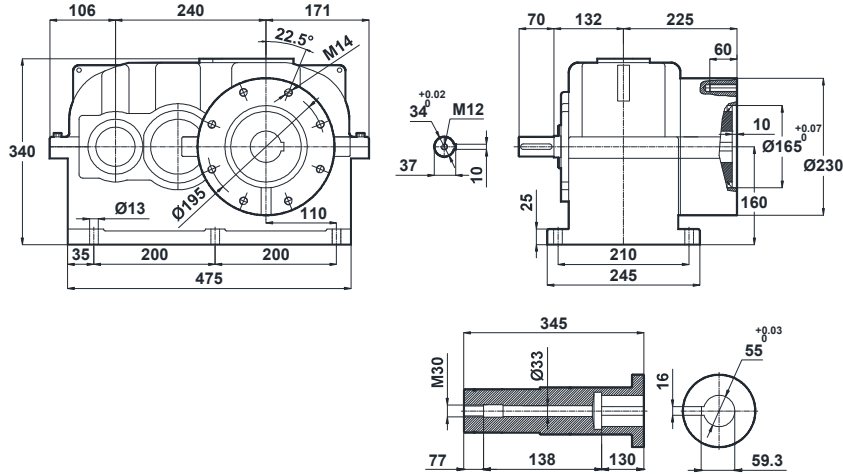

Max. Kovan Çapı = Ø55\*mm

Max. Hollow Diameter = Ø55\*mm

Max. Hohlwellendurchmesser = Ø55\*mm

\*=Opsiyon / Option / Sonderausführung

YRE2275.□

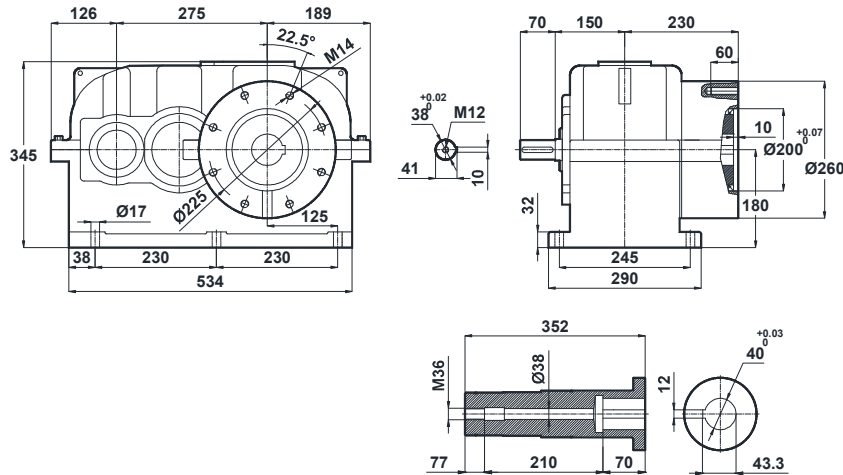

Max. Kovan Çapı = Ø60\*mm

Max. Hollow Diameter = Ø60\*mm

Max. Hohlwellendurchmesser = Ø60\*mm

\*=Opsiyon / Option / Sonderausführung





# Ölçü Sayfaları Dimension Pages Abmessungsseiten



-Mil ucu çektirme deliği DIN 332 sayfa 2 / Tapped center hole according to DIN 332, sheet 2 / Zentrierung mit Gewinde nach DIN 332, Blatt 2

YRE2305.□

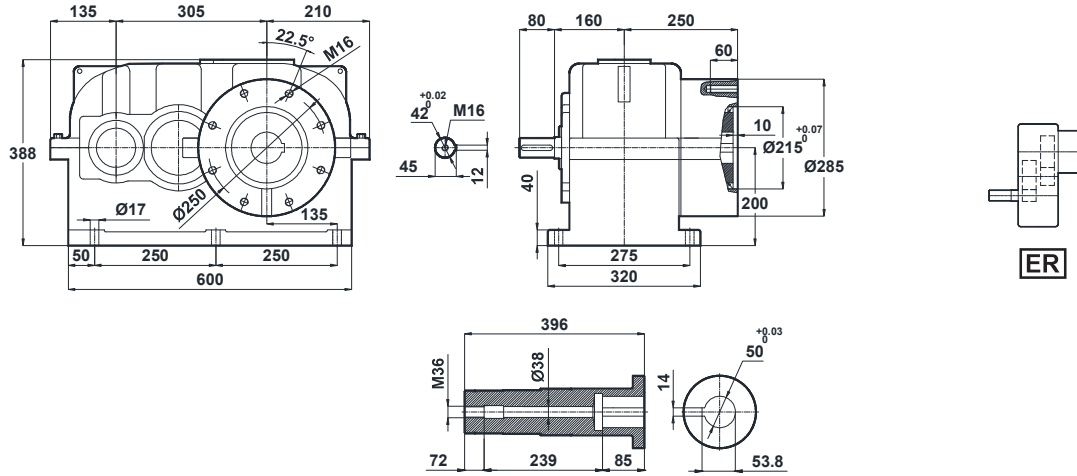

Max. Kovan Çapı =  $\varnothing 65^*mm$   
Max. Hollow Diameter =  $\varnothing 65^*mm$   
Max. Hohlwellendurchmesser =  $\varnothing 65^*mm$

\*=Opsiyon / Option / Sonderausführung

YRE2340.□

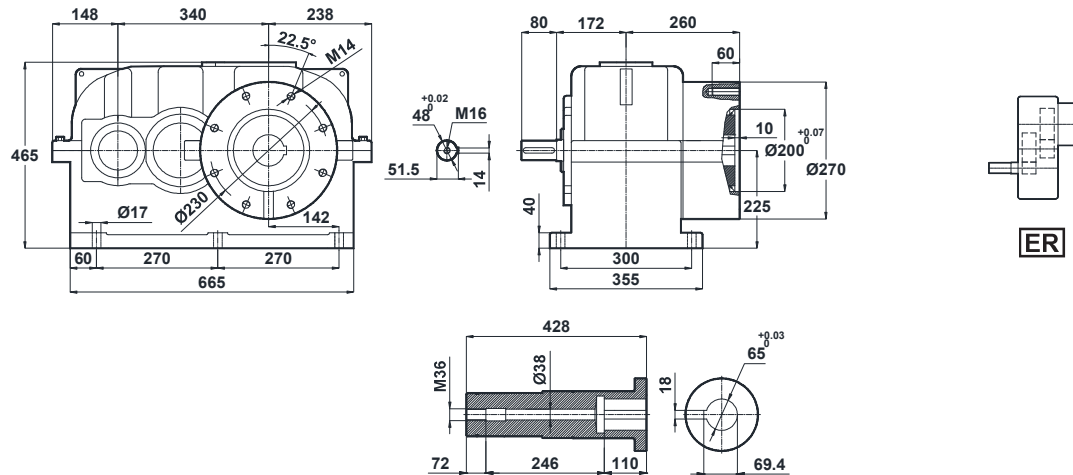

Ops.

Max. Kovan Çapı =  $\varnothing 75^*mm$   
Max. Hollow Diameter =  $\varnothing 75^*mm$   
Max. Hohlwellendurchmesser =  $\varnothing 75^*mm$

\*=Opsiyon / Option / Sonderausführung

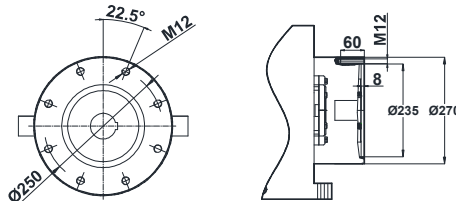

Std. 29322

Ops. 29422





# Ölçü Sayfaları Dimension Pages Abmessungsseiten



-Mil ucu çekirme deliği DIN 332 sayfa 2 / Tapped center hole according to DIN 332, sheet 2 / Zentrierung mit Gewinde nach DIN 332, Blatt 2

YRE2480.□

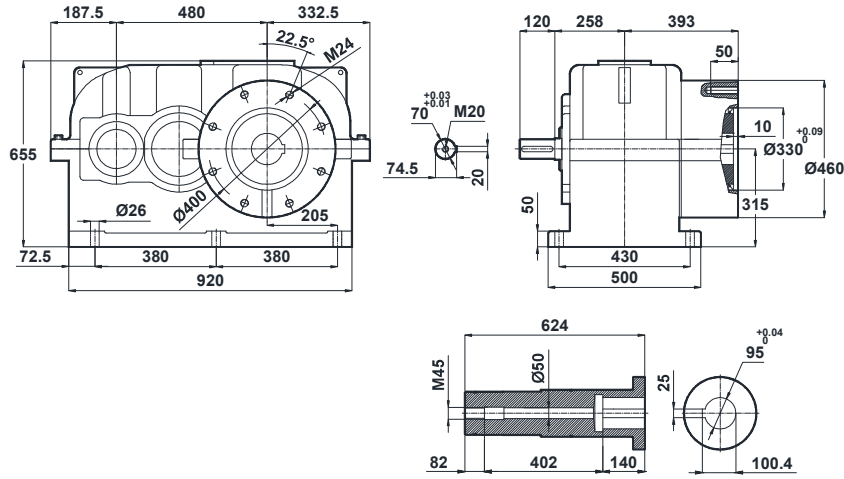

Max. Kovan Çapı = Ø110\*mm

Max. Hollow Diameter = Ø110\*mm

Max. Hohlwellendurchmesser = Ø110\*mm

\*=Opsiyon / Option / Sonderausführung

YRE2545.□

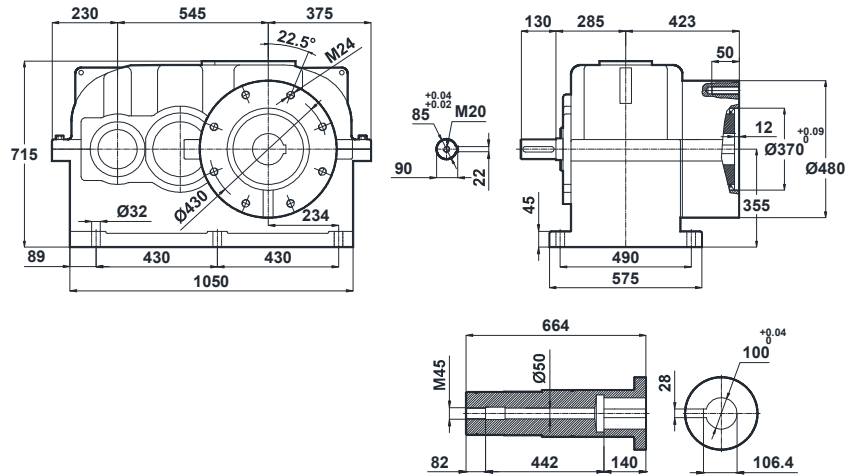

Max. Kovan Çapı = Ø120\*mm

Max. Hollow Diameter = Ø120\*mm

Max. Hohlwellendurchmesser = Ø120\*mm

\*=Opsiyon / Option / Sonderausführung















